

4

3

2

1

THIS DRAWING IS UNPUBLISHED. RELEASED FOR PUBLICATION  
 © COPYRIGHT BY TYCO ELECTRONICS CORPORATION. ALL RIGHTS RESERVED.

LOC		DIBT		REVISIONS			
FT	0	P	LTR	DESCRIPTION	DATE	MIN	APD
		K		REVISED PER ECO-07-009992	4/30/07	SS	SH

- CONTACT CAVITIES IDENTIFIED BY CHARACTERS ON FRONT FACE OF CONNECTOR.
- .000030 MIN GOLD FOR A LENGTH OF .100 MIN FROM MATING END, .000100 MIN TIN-LEAD FOR A LENGTH OF "A" MIN FROM OPPOSITE END, ALL OVER .000050 MIN NICKEL.
- RECOMMENDED HOLE SIZE .047 DIA FOR P.C. BOARD.
- .000030 MIN GOLD FOR A LENGTH OF .100 MIN FROM MATING END, .000100 MIN TIN FOR A LENGTH OF "A" MIN FROM OPPOSITE END, ALL OVER .000050 MIN NICKEL.

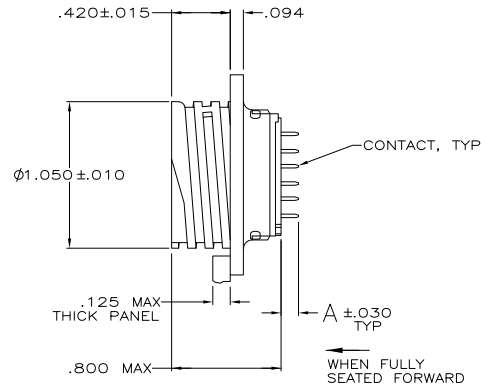
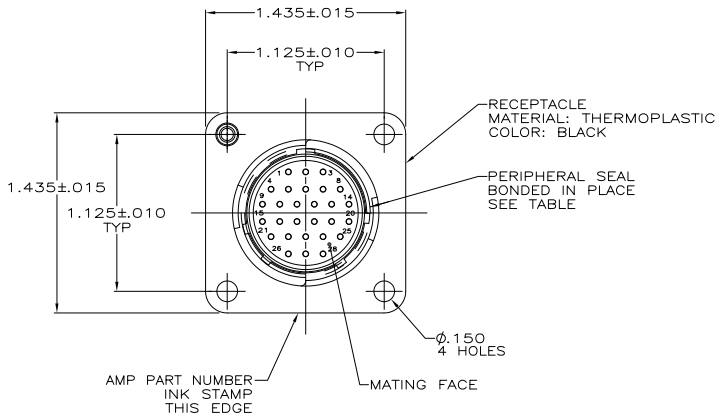

	NO	YES	.125	1-207369-4
	NO	NO	.352	1-207369-3
	NO	NO	.125	1-207369-1
	YES	YES	.796	207369-5
	NO	YES	.125	207369-4
	NO	NO	.352	207369-3
<b>OBSOLETE</b>	NO	NO	-	207369-2
	NO	NO	.125	207369-1
<b>CONTACT FINISH</b>	PERIPHERAL SEAL	THREADED INSERT	DIM A	PART NUMBER

THIS DRAWING IS A CONTROLLED DOCUMENT.		DATE: 5-22-91	Tyco Electronics Corporation	
DESIGNED BY: J. GALLUCCI, BG		DATE: 4-14-92	Harrisburg, Pa 17105-3608	
CHECKED BY: W. G. LENKER		DATE: 4-14-92	Tyco Electronics	
DRAWN BY: K. BEAVER		DATE:	RECEPTACLE ASSEMBLY, POSTED, STD SEX, SERIES 2, 17-28, CPC	
PART NUMBER: 108-10024		APPLICATION SPEC:	SIZE: A2	CAGE CODE: 00779
MATERIAL: SEE CALLOUT		FINISH:	DRAWING NO: C-207369	RESTRICTED TO:
CUSTOMER DRAWING		SCALE: 2:1	SHEET: 1 OF 1	REV: K

AMP 1471-9 REV 31MM2000

207369

A