

REV	DATE	DESCRIPTION	BY	CHK	APP
00		RELEASED PER EC DS12-0287-04			

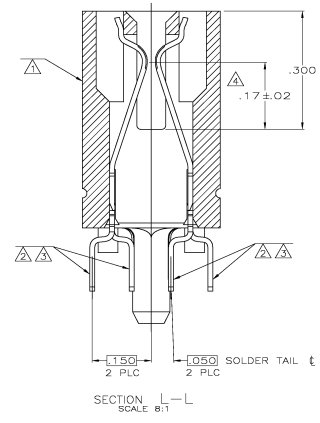

- △ HOUSING: HIGH TEMPERATURE THERMOPLASTIC. COLOR: BROWN.
- △ CONTACT: PHOSPHOR BRONZE.
- △ CONTACT FINISH: .000100 MIN NICKEL ALL OVER, .000030 MIN GOLD OVER NICKEL IN CONTACT AREA, .000100 MIN MATTE TIN OVER NICKEL ON SOLDER TAILS.
- △ DISTANCE FROM CONTACT POINT TO BOTTOM OF CARD SLOT.
- △ AMP PART NUMBER, DATE CODE AND CSA LOGO MARKED IN APPROXIMATE AREA SHOWN.

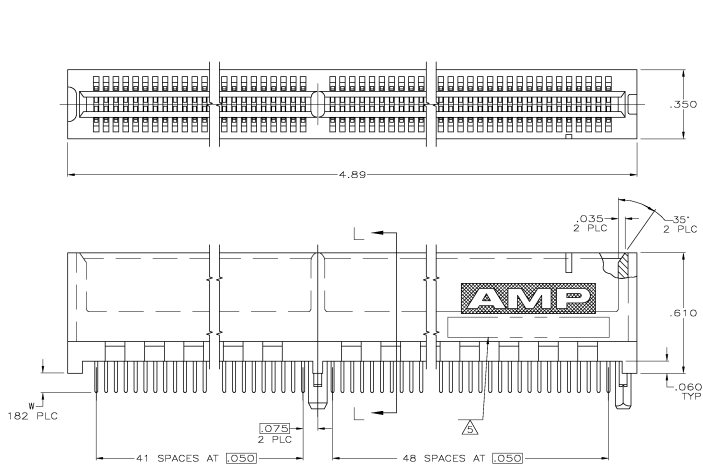
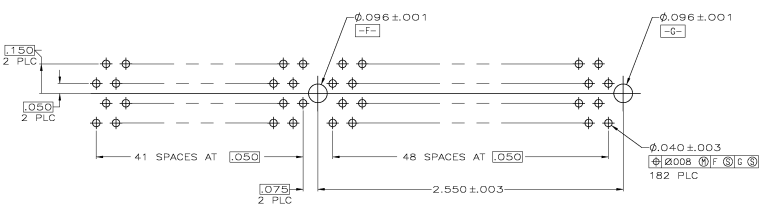
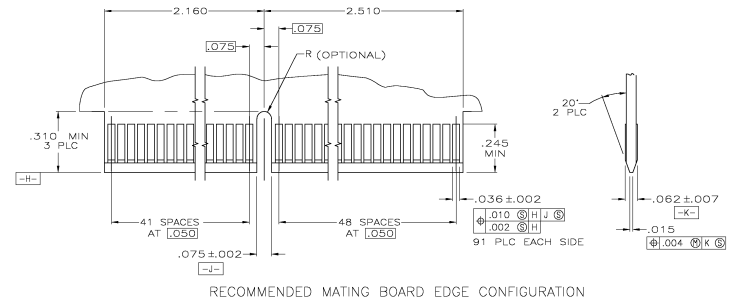
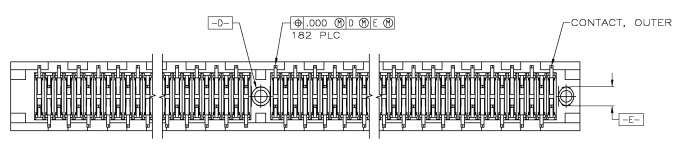

RECOMMENDED CONNECTOR MOUNTING HOLE PATTERN
 (CONNECTOR SIDE SHOWN)

1.4	5650092-2
1.0	5650092-1
W	PART NUMBER

THIS DRAWING IS A CONTROLLED DOCUMENT.		REV. 1	DATE 24 JAN 98	BY AWF	CHK AWF
DRAWN BY		DESIGNED BY	DATE	BY	CHK
CHECKED BY		APPROVED BY	DATE	BY	CHK
MATERIAL		QUANTITY	DATE	BY	CHK
REVISIONS		DESCRIPTION	DATE	BY	CHK
CUSTOMER DRAWING		DATE	BY	CHK	APP