

NUMBER C-1734443
3RD ANGLE PROJECTION
METRIC

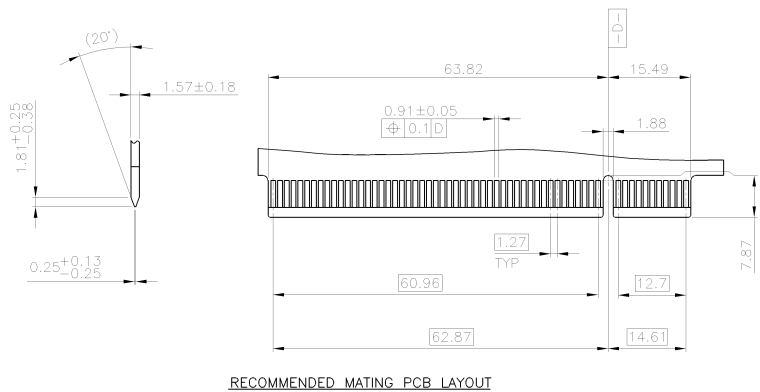
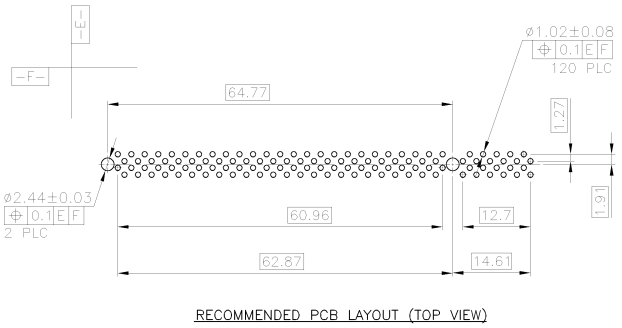
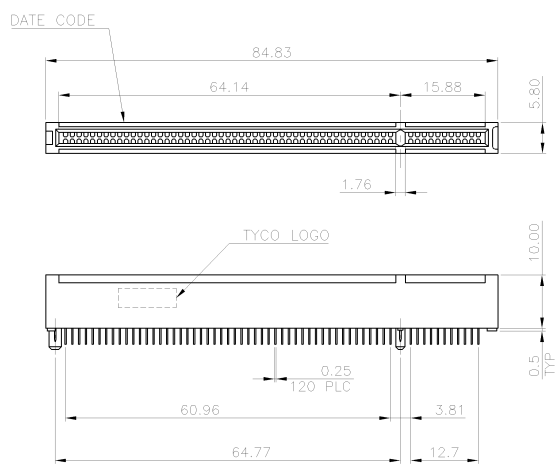

- NOTE:
- MATERIAL:
HOUSING: THERMOPLASTIC (PA46) WITH 30% GF, UL 94V-0, NATURE COLOR.
CONTACTS: PHOSPHOR BRONZE.
 - FINISH:
CONTACTS: (SEE TABLE) GOLD PLATED ON CONTACT AREA, 2.54 μm [100 $\mu\text{\"}$] MIN. TIN-COPPER ON SOLDER TAIL, WITH ENTIRE CONTACT UNDERPLATED 1.27 μm [50 $\mu\text{\"}$] MIN. NICKEL.
 - WAVE SOLDER CAPABLE TO 265°C AS PER TYCO SPEC. 109-202, CONDITION B.

0.381 μm [15 $\mu\text{\"}$]	1734443-2
GOLD FLASH	1734443-1
MIN. GOLD THICKNESS	PART NUMBER

TOLERANCES UNLESS OTHERWISE SPECIFIED:	DWN	A. WU	tyco TYCO HOLDINGS (BERMUDA)	
0 PLC ±	31-MAR-2006	S. HOU	VII LTD. TAIWAN BRANCH	
1 PLC ±0.3	CHK	31-MAR-2006	NAME	
2 PLC ±0.2	APVD	W.J. KE	CARD EDGE, SLIM PCI 120 POS, LOW PROFILE	
3 PLC ±	PRODUCT SPEC	31-MAR-2006	LOC SIZE DRAWING NO	
ANGLES ±3°	108-57349	501-57444	DW A ₃	C-1734443
MATERIAL	QUALIFICATION TEST REPORT	4.87 GRAMS	SCALE	SHEET
SEE NOTE	501-57444		--	1 OF 2
FINISH	WEIGHT			
SEE NOTE	4.87 GRAMS			

A	FIRST RELEASED	--	AW	31MAR
LTR	REVISION RECORD	ECN	DWN	2006
			CHK	DATE

THIS INFORMATION IS CONFIDENTIAL AND IS RELEASED TO YOU ON CONDITION THAT NO FURTHER DISCLOSURE IS MADE BY YOU TO OTHER THAN AMP PERSONNEL WITHOUT DIMENSIONS IN MILLIMETERS. DO NOT SCALE PRINT.

8 | 7 | 6 | 5 | 4 | 3 | 2 | 1
CUSTOMER DRAWING

NUMBER C-1734443
 METRIC
 3RD ANGLE PROJECTION

THIS INFORMATION IS CONFIDENTIAL AND IS RELEASED TO YOU ON CONDITION THAT NO FURTHER DISCLOSURE IS MADE BY YOU TO OTHER THAN AMP PERSONNEL WITHOUT DIMENSIONS IN MILLIMETERS. DO NOT SCALE PRINT.

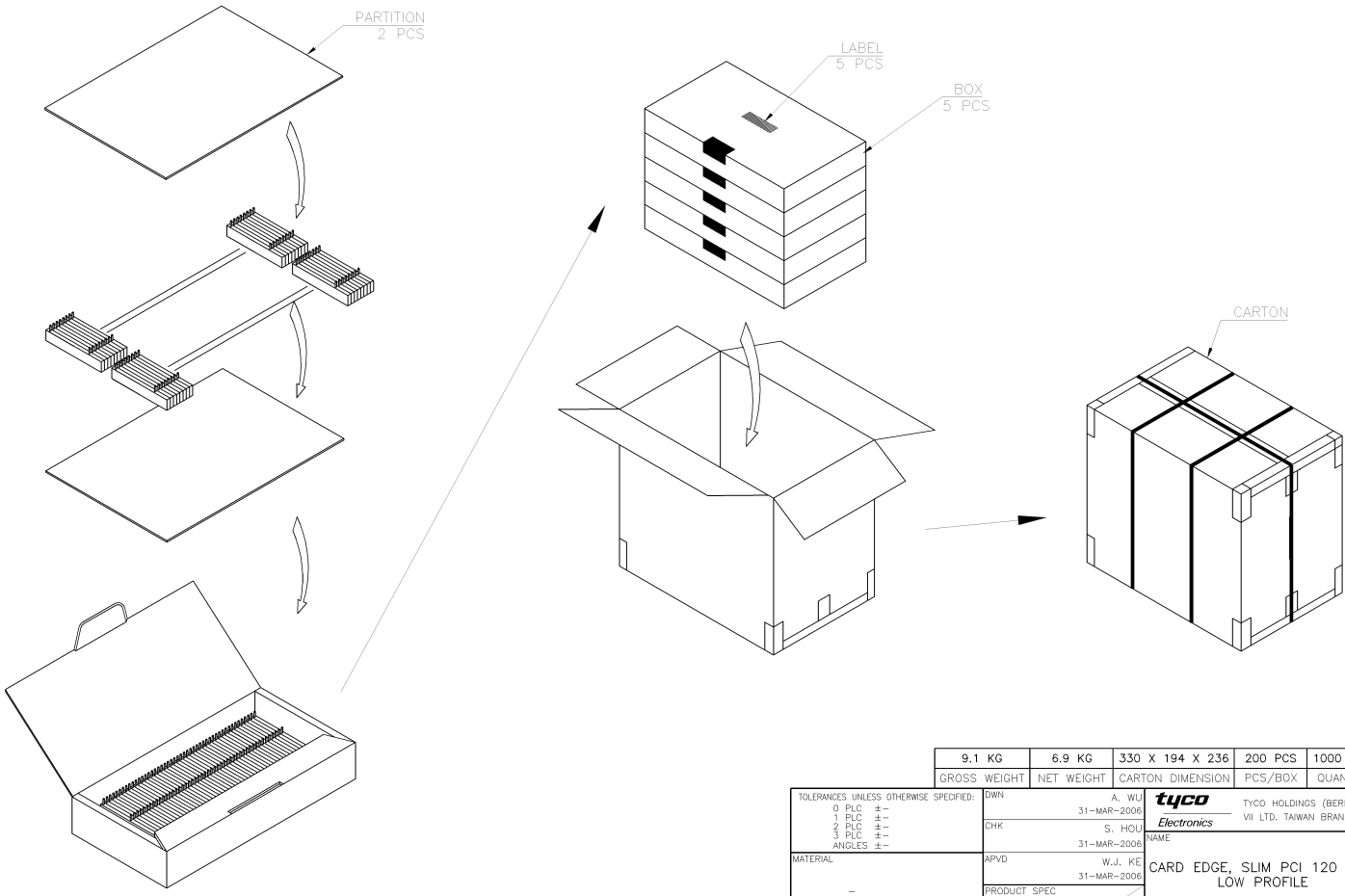

9.1 KG	6.9 KG	330 X 194 X 236	200 PCS	1000 PCS
GROSS WEIGHT	NET WEIGHT	CARTON DIMENSION	PCS/BOX	QUANTITY
TOLERANCES UNLESS OTHERWISE SPECIFIED:		DWN	A. WU 31-MAR-2006	
0	PLC	±	tyco TYCO HOLDINGS (BERMUDA)	
1	PLC	±	S. HOU 31-MAR-2006	
2	PLC	±	NAME Electronics	
3	PLC	±	TYCO HOLDINGS (BERMUDA)	
ANGLES		±	VII LTD. TAIWAN BRANCH	
MATERIAL		APVD	W.J. KE 31-MAR-2006	
-		PRODUCT SPEC	CARD EDGE, SLIM PCI 120 POS, LOW PROFILE	
FINISH		APPLICATION SPEC	LOC	SIZE
-		WEIGHT	DW	A ₃
			SCALE	DRAWING NO
			--	C-1734443
				REV
				A
				SHEET
				2 OF 2

SEE SHEET 1.	ECN	DWN/CHK	DATE
LTR	REVISION RECORD		

CUSTOMER DRAWING