

REVISION AC

**DESIGNED & DIMENSIONED
IN MILLIMETERS
(INCHES FOR REFERENCE ONLY)**

HSEC8-1XXX-XX-XX-DV-X-XX

DO NOT
SCALE FROM
THIS PRINT

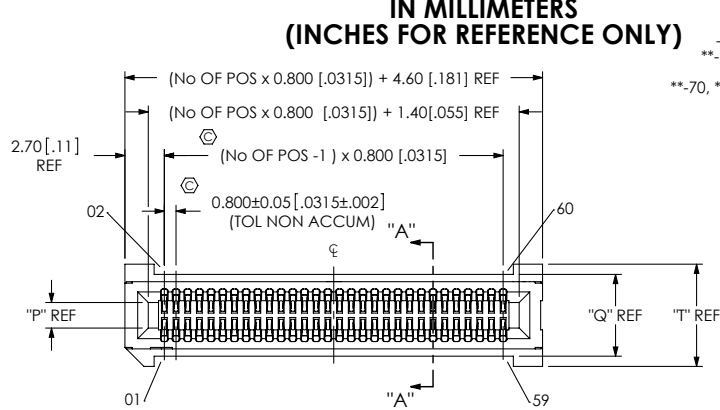

No OF POSITIONS

- 10, -20, & -30 (SEE FIG 1)
- **13, **25, **37, -40, **49, -50, & -60 (SEE FIG 2)
- **70, **80, **90 & **100 (PER ROW)

CARD THICKNESS
(SEE NOTE 6 & 7)

PLATING SPECIFICATION

- SM: SELECTIVE GOLD/MATTE TIN TAIL (USE C-188-01-S)
- H: HEAVY GOLD/FLASH GOLD TAIL (USE C-188-01-H)
- S: SELECTIVE GOLD/MATTE TIN TAIL (USE C-188-01-S)
- L: LIGHT SELECTIVE GOLD/MATTE TIN TAIL (USE C-188-01-L)

ROW SPECIFICATION

- OPTION**
- K: POLYIMIDE FILM PAD (SEE FIG 3) (SEE TABLE 6)
 - TR: TAPE & REEL (-10 THRU -70 POS ONLY) (LEAVE BLANK FOR TRAY)
 - **L: LATCHING OPTION. NOT AVAILABLE FOR -GR TYPE USE (USE HSEC8-XXX-01-DV-A-L) (AVAILABLE IN **13, **25, **37 & **49 POS ONLY) (SEE SHEET 3, FIG 4)
 - **L2: ECDP LATCHING OPTION. NOT AVAILABLE FOR -GR USE (USE HSEC8-XXX-01-DV-A-L2) (AVAILABLE IN **26, **50, **74 & **98 POS ONLY) (SEE SHEET 7, FIG 9)
 - **BL: BOARD LOCK OPTION. NOT AVAILABLE FOR -GR TYPE USE (USE HSEC8-XXX-01-DV-XX-BL) (SEE SHEET 4, FIG 5)
 - **GR: GUIDE RAILS. NOT AVAILABLE FOR -L: -BL TYPE USE (SEE SHEET 5, FIG 6) (USE HSEC8-XXX-01-DV-XX-GR) (PACKAGING -TR ONLY)
 - **PE: PASS THROUGH (AVAILABLE IN -10, -13 & -20 POS ONLY) (ONLY AVAILABLE WITH -A OPTION) (SEE SHEET 6, FIG 7)
 - WT: WELD TABS (-A OPTION REQUIRED) (SEE SHEET 6, FIG 8)

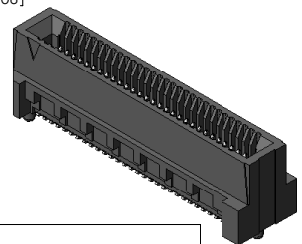
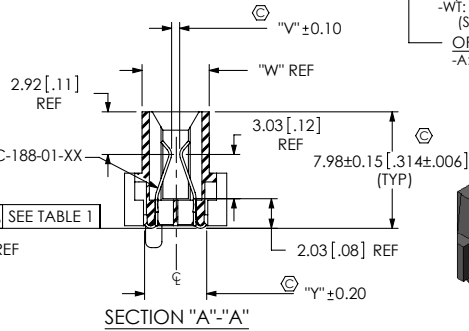
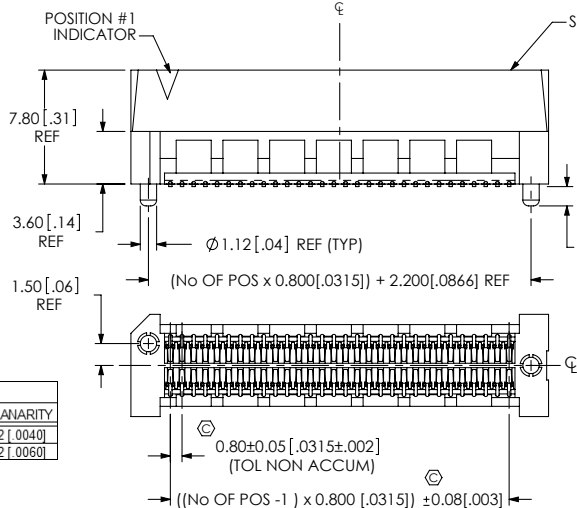

** = AVAILABLE ONLY WITH -01 CARD THICKNESS

No OF POS	COPLANARITY
-10 THRU -60	0.102 [.0040]
-70 THRU -100	0.152 [.0060]

NOTES:

- ⊙ REPRESENTS A CRITICAL DIMENSION.
- BURR ALLOWANCE: 0.04[.0015] MAX.
- MINIMUM PUSHOUT FORCE: 2.2 NEWTONS.
- ALL TAIL TO TAIL DIMENSIONS MEASURED TIP TO TIP.
- ASSEMBLIES TO BE PACKAGED IN TRAYS.
- CARD THICKNESS OPTION
 - 01: 1.57mm[.062] THICK CARD USE HSEC8-XXX-01-DV-XX
 - 02: 2.00mm[.079] THICK CARD USE HSEC8A-XXX-02-DV-XX FOR POSITIONS 10, 20, 30, 40, 50 AND 60 ONLY.
 - 03: 2.36mm[.093] THICK CARD USE HSEC8A-XXX-03-DV-XX FOR POSITIONS 10, 20, 30, 40, 50 AND 60 ONLY.
 - *-04: 3.18mm[.125] THICK CARD USE HSEC8A-XXX-04-DV-XX FOR POSITIONS 10, 20, 30, 40, 50 AND 60 ONLY.
- MATING EDGE CARD THICKNESS TOLERANCE TO BE ±10% OF NOMINAL.

FIG 1
FOR POSITIONS -10, -20 & -30
(SHOWN: HSEC8-130-01-XX-D-DV-A)

CARD THICKNESS	BODY	"P"	"Q"	"T"	"V"	"W"	"Y"
-01	HSEC8-XXX-01-DV-XX	1.75[.070]	5.60[.220]	7.00[.280]	0.55[.022]	4.60[.180]	4.25[.167]
-02	HSEC8A-XXX-02-DV-XX	2.18[.086]	6.03[.237]	7.43[.293]	0.98[.038]	5.03[.198]	4.68[.184]
-03	HSEC8A-XXX-03-DV-XX	2.54[.100]	6.39[.252]	7.79[.307]	1.34[.053]	5.39[.212]	5.04[.198]
*-04	HSEC8A-XXX-04-DV-XX	3.36[.132]	7.21[.284]	8.61[.339]	2.16[.085]	6.21[.244]	5.86[.230]

* = NOT RELEASED FOR PRODUCTION

UNLESS OTHERWISE SPECIFIED, DIMENSIONS ARE IN MILLIMETERS.
TOLERANCES ARE:
DECIMALS ANGLES
.X: ±.3 [.011] 2°
.XX: ±.13 [.005]
.XXX: ±.051 [.0020]

PROPRIETARY NOTE
THIS DOCUMENT CONTAINS INFORMATION CONFIDENTIAL AND PROPRIETARY TO SAMTEC, INC. AND SHALL NOT BE REPRODUCED OR TRANSFERRED TO OTHER DOCUMENTS OR DISCLOSED TO OTHERS OR USED FOR ANY PURPOSE OTHER THAN THAT WHICH IT WAS OBTAINED WITHOUT THE EXPRESSED WRITTEN CONSENT OF SAMTEC, INC.

samtec
520 PARK EAST BLVD, NEW ALBANY, IN 47150
PHONE: 812-944-6733 FAX: 812-948-5047
e-Mail: info@SAMTEC.com code: 55322

MATERIAL: DO NOT SCALE DRAWING SHEET SCALE: 2.5:1
INSULATOR: LCP
COLOR: -01 CARD THICKNESS BLACK, -02 THRU -04 CARD THICKNESS NATURAL
CONTACT: BeCu

DESCRIPTION: 0.8mm HIGH SPEED ASSEMBLY
DWG. NO. HSEC8-1XXX-XX-XX-DV-X-XX
BY: BRATCHER 01/24/03 **SHEET 1 OF 7**

REVISION AC

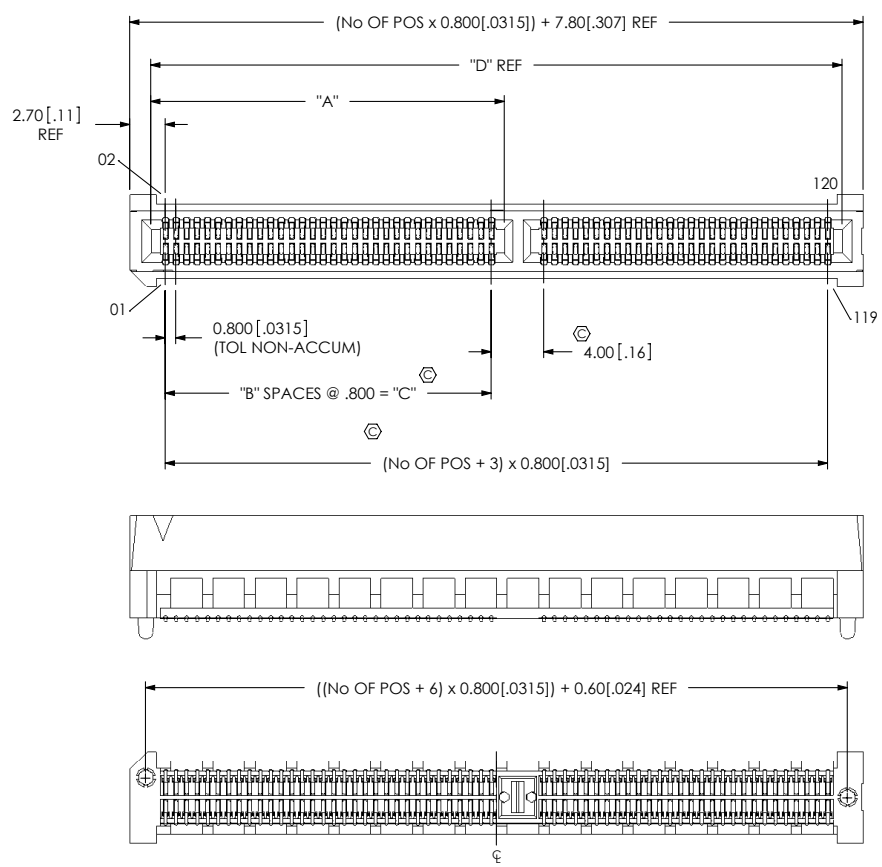

No OF POS	"A" REF	"B"	"C"	"D" REF	"G" REF
**13	6.10 [240]	5	4.00 [1575]	15.00 [591]	6.90 [270]
**25	6.10 [240]	5	4.00 [1575]	24.60 [969]	16.50 [648]
**37	18.10 [713]	20	16.00 [6299]	34.20 [1.346]	14.10 [554]
-40	18.90 [744]	21	16.80 [6614]	36.60 [1.441]	15.70 [617]
**49	22.90 [902]	26	20.80 [8189]	43.80 [1.724]	18.90 [743]
-50	22.90 [902]	26	20.80 [8189]	44.60 [1.756]	19.70 [774]
-60	26.90 [1.059]	31	24.80 [9763]	52.60 [2.071]	23.70 [932]
**70	26.90 [1.059]	31	24.80 [9763]	60.60 [2.386]	31.70 [1.247]
**80	26.90 [1.059]	31	24.80 [9763]	68.80 [2.701]	39.70 [1.562]
**90	26.90 [1.059]	31	24.80 [9763]	76.60 [3.016]	47.70 [1.877]
**100	26.90 [1.059]	31	24.80 [9763]	84.60 [3.331]	55.70 [2.192]

** = AVAILABLE ONLY WITH -01 CARD THICKNESS

FIG 2
FOR POSITIONS **13, **25, **37, -40, **49, -50, -60, **70, **80, **90, **100 (SAME AS FIG. 1, UNLESS OTHERWISE STATED) (SHOWN: HSEC8-160-01-XX-DV-A) (** = AVAILABLE ONLY WITH -01 CARD THICKNESS)

FIG 3
-K OPTION

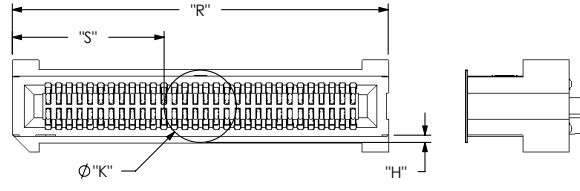

OPTION	No OF POS	"R"	"S"
NONE	-10 THRU -30	(No OF POS x 0.80[.0315]) + 4.60[.181] REF	
	-13, -25, -37, -40 THRU -100	(No OF POS x 0.80[.0315]) + 7.80[.307] REF	
**L	-13, -25, -37, & -49	(No OF POS x 0.80[.0315]) + 18.40[.724] REF	((R" - "K") / 2) +/- 0.51[.020]
**BL	-10 THRU -30	(No OF POS x 0.80[.0315]) + 15.85[.624] REF	
	-13, -25, -37, -40 THRU -100	(No OF POS x 0.80[.0315]) + 19.05[.750] REF	

** = AVAILABLE ONLY WITH -01 CARD THICKNESS

CARD THICKNESS	BODY	KAPTON TYPE "K"	"U"	"H"
-01	HSEC8-XXX-01-DV-XX	K-DOT-217-313-005	2.61 [102]	0.45 [018]
-02	HSEC8A-XXX-02-DV-XX	K-DOT-217-313-005	3.04 [120]	0.24 [009]
-03	HSEC8A-XXX-03-DV-XX	K-DOT-246-375-005	3.40 [134]	0.43 [017]
*-04	HSEC8A-XXX-04-DV-XX	K-DOT-246-375-005	4.22 [166]	0.40 [016]

* = NOT RELEASED FOR PRODUCTION

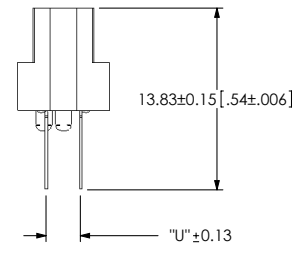

IN-PROCESS

F:\dwg\misc\mktg\HSEC8-1000-XX-XX-DV-X-XX-MKTLDDRW

<p>PROPRIETARY NOTE</p> <p>THIS DOCUMENT CONTAINS INFORMATION CONFIDENTIAL AND PROPRIETARY TO SAMTEC, INC. AND SHALL NOT BE REPRODUCED OR TRANSFERRED TO OTHER DOCUMENTS OR DISCLOSED TO OTHERS OR USED FOR ANY PURPOSE OTHER THAN THAT WHICH IT WAS OBTAINED WITHOUT THE EXPRESSED WRITTEN CONSENT OF SAMTEC, INC.</p>		
	<p>520 PARK EAST BLVD, NEW ALBANY, IN 47150 PHONE: 812-944-6733 FAX: 812-948-5047 e-Mail: info@SAMTEC.com code: 55322</p>	
<p>DO NOT SCALE DRAWING</p>	<p>DESCRIPTION: 0.8mm HIGH SPEED ASSEMBLY</p>	
<p>SHEET SCALE: 2.25:1</p>	<p>DWG. NO. HSEC8-1XXX-XX-XX-DV-X-XX</p>	
	<p>BY: BRATCHER 01/24/03</p>	<p>SHEET 2 OF 7</p>

REVISION AC

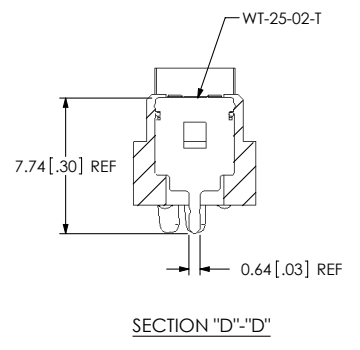
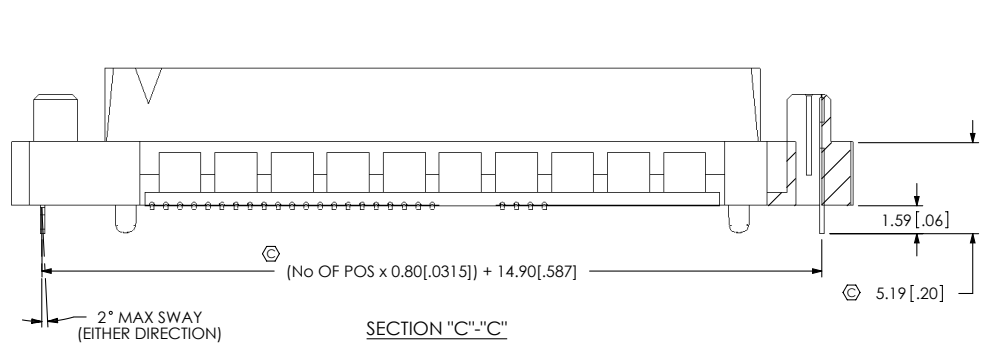
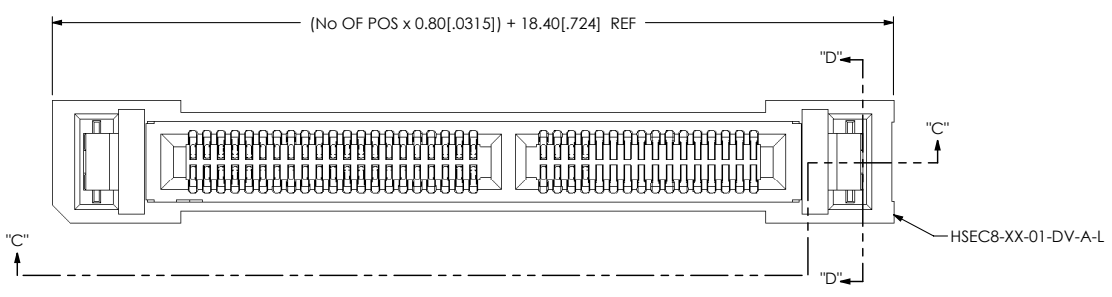

FIG 4
 **L: LATCHING OPTION
 AVAILABLE IN -13, -25, -37 & -49 POSITIONS ONLY
 NOT AVAILABLE FOR -GR TYPE USE
 (SAME AS FIG. 2, UNLESS OTHERWISE STATED)
 (SHOWN: HSEC8-137-01-XX-DV-A-L)
 (** = AVAILABLE ONLY WITH -01 CARD THICKNESS)

PROPRIETARY NOTE
 THIS DOCUMENT CONTAINS INFORMATION
 CONFIDENTIAL AND PROPRIETARY TO
 SAMTEC, INC. AND SHALL NOT BE REPRODUCED
 OR TRANSFERRED TO OTHER DOCUMENTS OR
 DISCLOSED TO OTHERS OR USED FOR ANY
 PURPOSE OTHER THAN THAT WHICH IT WAS
 OBTAINED WITHOUT THE EXPRESSED WRITTEN
 CONSENT OF SAMTEC, INC.

DO NOT SCALE DRAWING

SHEET SCALE: 3:1

samtec	
520 PARK EAST BLVD, NEW ALBANY, IN 47150 PHONE: 812-944-6733 FAX: 812-948-5047 E-Mail: info@SAMTEC.com code: 53322	
DESCRIPTION: 0.8mm HIGH SPEED ASSEMBLY	
DWG. NO. HSEC8-1XXX-XX-XX-DV-X-XX	
BY: BRATCHER 01/24/03	SHEET 3 OF 7

F:\dwg\misc\mktg\HSEC8-1XXX-XX-XX-DV-X-XX-MKT.SLDDRW

REVISION AC

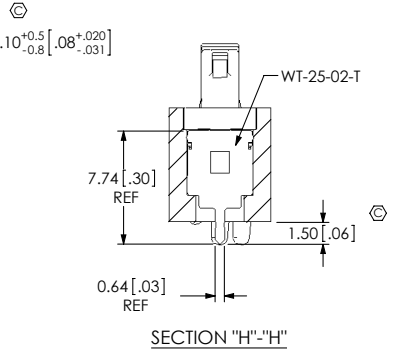
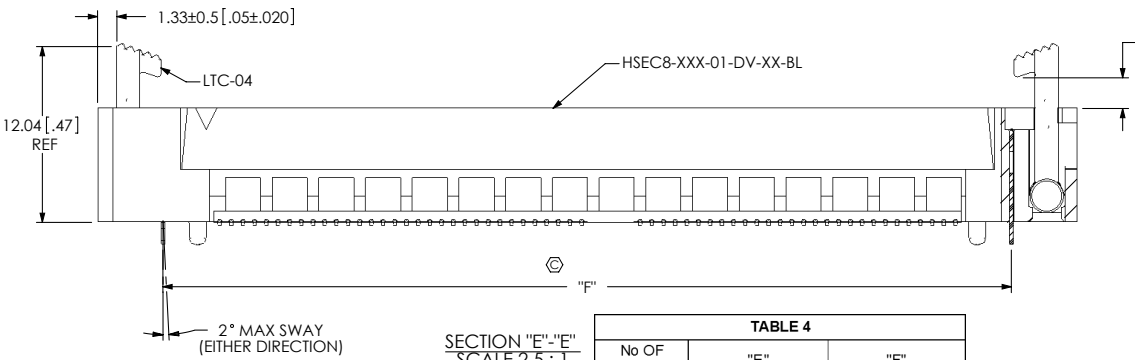
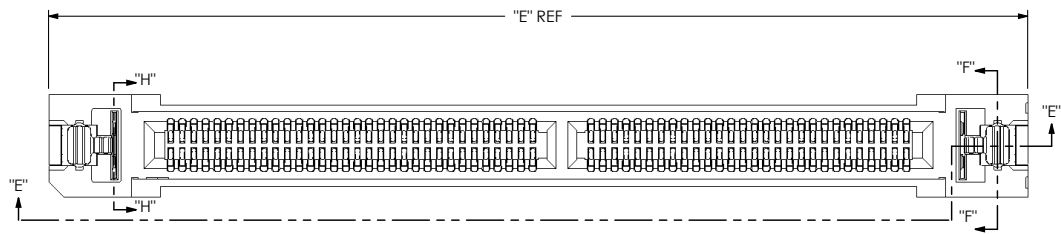
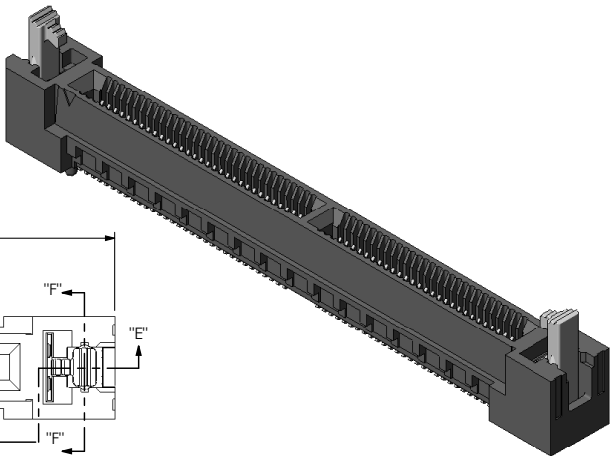

SECTION "E"- "E"
SCALE 2.5 : 1

SECTION "H"- "H"

No OF POSITIONS	TABLE 4	
	"E"	"F"
-10	23.85 [0.939]	14.90 [0.587]
** -13	29.45 [1.159]	20.50 [0.807]
-20	31.85 [1.254]	22.90 [0.902]
** -25	39.05 [1.537]	30.10 [1.185]
-30	39.85 [1.569]	30.90 [1.217]
** -37	48.65 [1.915]	39.70 [1.563]
-40	51.05 [2.010]	42.10 [1.657]
** -49	58.25 [2.293]	49.30 [1.941]
-50	59.05 [2.325]	50.10 [1.972]
-60	67.05 [2.640]	58.10 [2.287]
** -70	75.05 [2.955]	66.10 [2.602]
** -80	83.05 [3.270]	74.10 [2.917]
** -90	91.05 [3.585]	82.10 [3.232]
** -100	99.05 [3.900]	90.10 [3.547]

PROPRIETARY NOTE
THIS DOCUMENT CONTAINS INFORMATION CONFIDENTIAL AND PROPRIETARY TO SAMTEC, INC. AND SHALL NOT BE REPRODUCED OR TRANSFERRED TO OTHER DOCUMENTS OR DISCLOSED TO OTHERS OR USED FOR ANY PURPOSE OTHER THAN THAT WHICH IT WAS OBTAINED WITHOUT THE EXPRESSED WRITTEN CONSENT OF SAMTEC, INC.

samtec
520 PARK EAST BLVD, NEW ALBANY, IN 47150
PHONE: 812-944-6733 FAX: 812-948-5047
e-Mail: info@SAMTEC.com code: 55322

DO NOT SCALE DRAWING
SHEET SCALE: 2.5:1

DESCRIPTION: 0.8mm HIGH SPEED ASSEMBLY
DWG. NO. HSEC8-1XXX-XX-XX-DV-X-XX
BY: BRATCHER 01/24/03 SHEET 4 OF 7

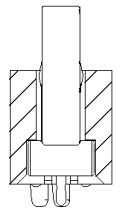

FIG 5
**-BL: BOARD LOCK OPTION
NOT AVAILABLE FOR -GR TYPE USE
(SAME AS FIG. 2, UNLESS OTHERWISE STATED)
(SHOWN: HSEC8-160-01-XX-DV-A-BL)
(** = AVAILABLE ONLY WITH -01 CARD THICKNESS)

SECTION "E"- "F"
SCALE 2.5 : 1

F:\dwg\misc\mktg\HSEC8-1XXX-XX-XX-DV-X-XX-MKT.SLDDRW

REVISION AC

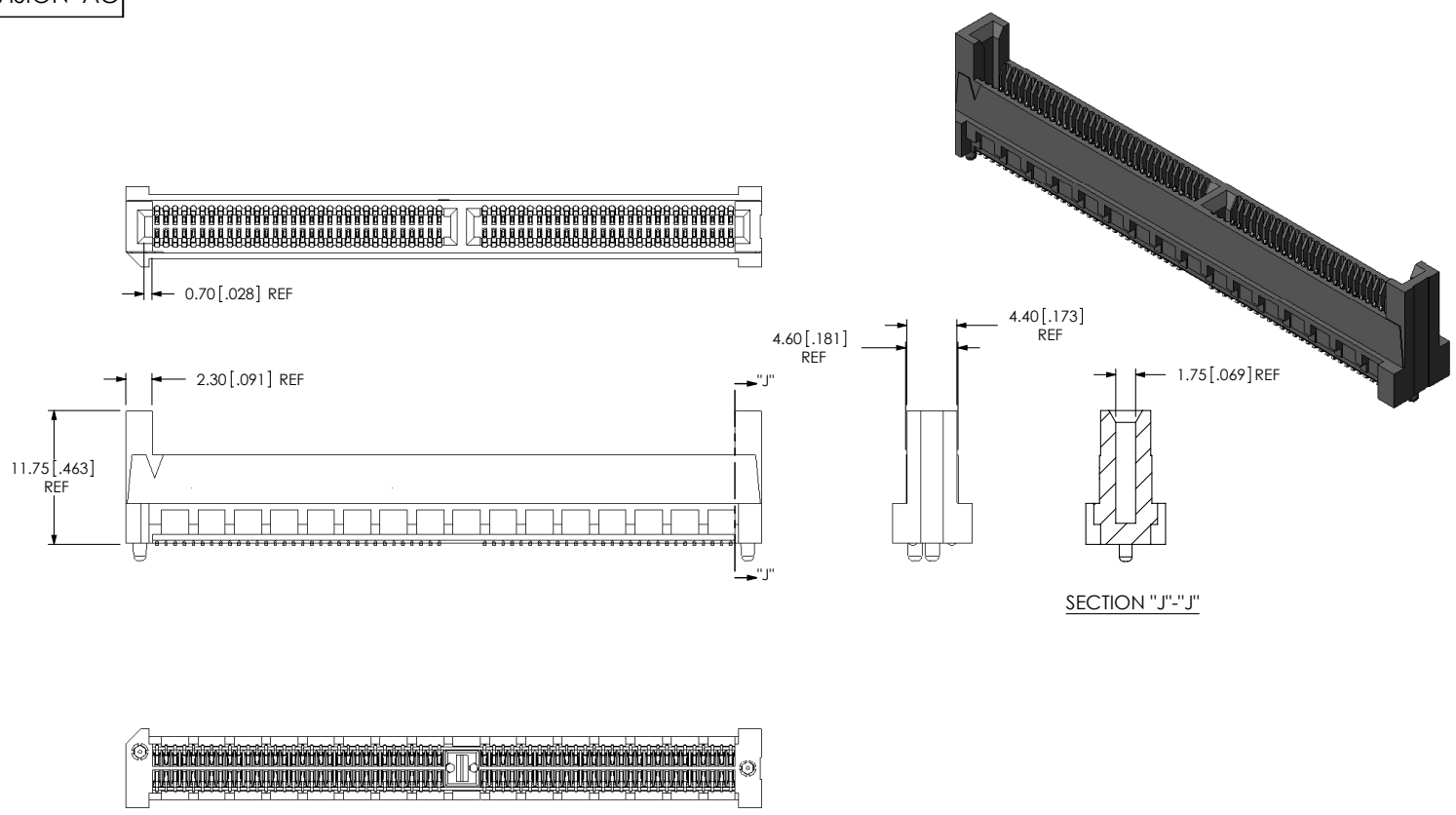



FIG 6
 ** -GR: GUIDE RAILS OPTION
 AVAILABLE IN -10, -20, -30, -40, -50, & -60 POSITIONS ONLY
 NOT AVAILABLE FOR -L; -BL TYPE USE
 (SAME AS FIG. 2, UNLESS OTHERWISE STATED)
 (SHOWN: HSEC8-160-01-XX-DV-A-GR)
 (** = AVAILABLE ONLY WITH -01 CARD THICKNESS)

PROPRIETARY NOTE
 THIS DOCUMENT CONTAINS INFORMATION
 CONFIDENTIAL AND PROPRIETARY TO
 SAMTEC, INC. AND SHALL NOT BE REPRODUCED
 OR TRANSFERRED TO OTHER DOCUMENTS OR
 DISCLOSED TO OTHERS OR USED FOR ANY
 PURPOSE OTHER THAN THAT WHICH IT WAS
 OBTAINED WITHOUT THE EXPRESSED WRITTEN
 CONSENT OF SAMTEC, INC.

DO NOT SCALE DRAWING

SHEET SCALE: 2:1

 520 PARK EAST BLVD, NEW ALBANY, IN 47150 PHONE: 812-944-6733 FAX: 812-948-5047 e-Mail: info@SAMTEC.com code: 55322	
DESCRIPTION:	0.8mm HIGH SPEED ASSEMBLY
DWG. NO.	HSEC8-1XXX-XX-XX-DV-X-XX
BY: BRATCHER 01/24/03	SHEET 5 OF 7

F:\dwg\misc\mktg\HSEC8-1XXX-XX-XX-DV-X-XX-MKT.SLDDRW

REVISION AC

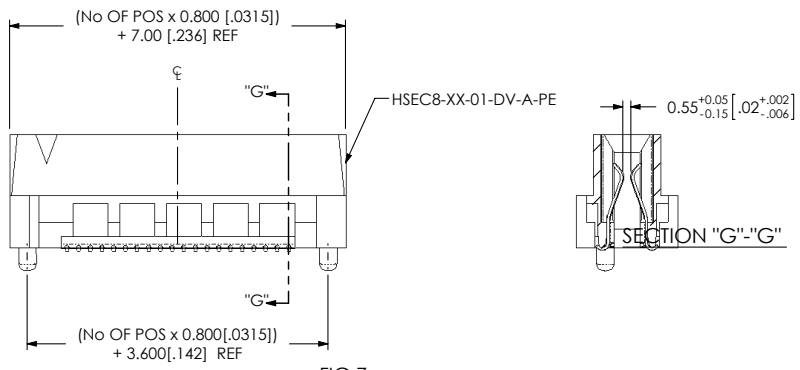

FIG 7
 **-PE: PASS THROUGH OPTION
 AVAILABLE IN -10, -13 & -20 POSITIONS ONLY
 (SAME AS FIG. 1, UNLESS OTHERWISE STATED)
 (SHOWN: HSEC8-120-01-XX-DV-A-PE)
 ** = AVAILABLE ONLY WITH -01 CARD THICKNESS

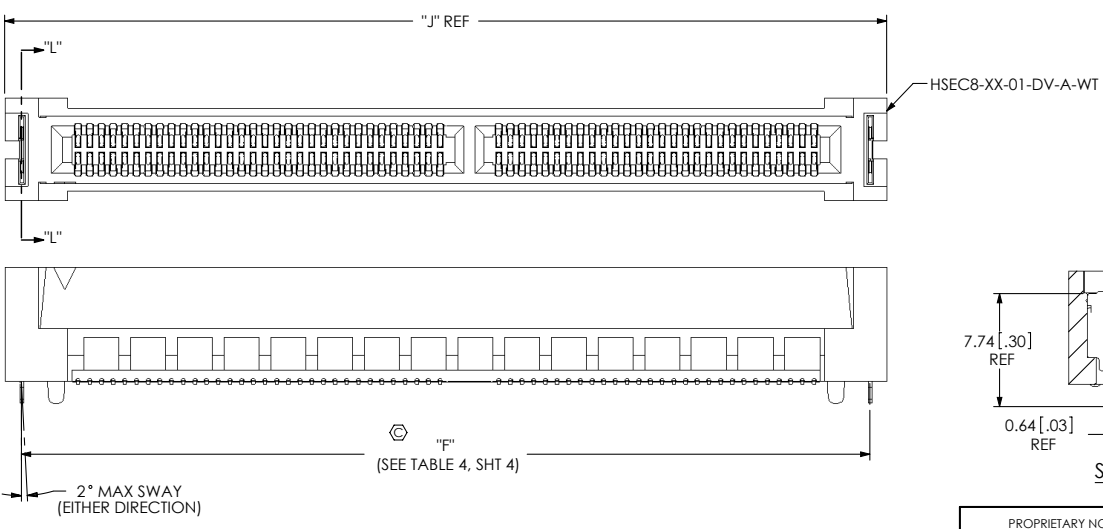

FIG 8
 -WT: WELD TAB OPTION
 AVAILABLE IN ALL POSITIONS
 (-A OPTION REQUIRED)
 (SAME AS FIG. 5, UNLESS OTHERWISE STATED)
 (SHOWN: HSEC8-160-01-XX-DV-A-WT)

** = AVAILABLE ONLY WITH -01 CARD THICKNESS

PROPRIETARY NOTE
 THIS DOCUMENT CONTAINS INFORMATION
 CONFIDENTIAL AND PROPRIETARY TO
 SAMTEC, INC. AND SHALL NOT BE REPRODUCED
 OR TRANSFERRED TO OTHER DOCUMENTS OR
 DISCLOSED TO OTHERS OR USED FOR ANY
 PURPOSE OTHER THAN THAT WHICH IT WAS
 OBTAINED WITHOUT THE EXPRESSED WRITTEN
 CONSENT OF SAMTEC, INC.

DO NOT SCALE DRAWING

SHEET SCALE: 2:1

520 PARK EAST BLVD, NEW ALBANY, IN 47150 PHONE: 812-944-6733 FAX: 812-948-5047 e-Mail info@SAMTEC.com code: 55322	
DESCRIPTION:	0.8mm HIGH SPEED ASSEMBLY
DWG. NO.	HSEC8-1XXX-XX-XX-DV-X-XX
BY: BRATCHER 01/24/03	SHEET 6 OF 7

F:\dwg\misc\mktg\HSEC8-1XXX-XX-XX-DV-X-XX-MKT.SLDDRW

REVISION AC

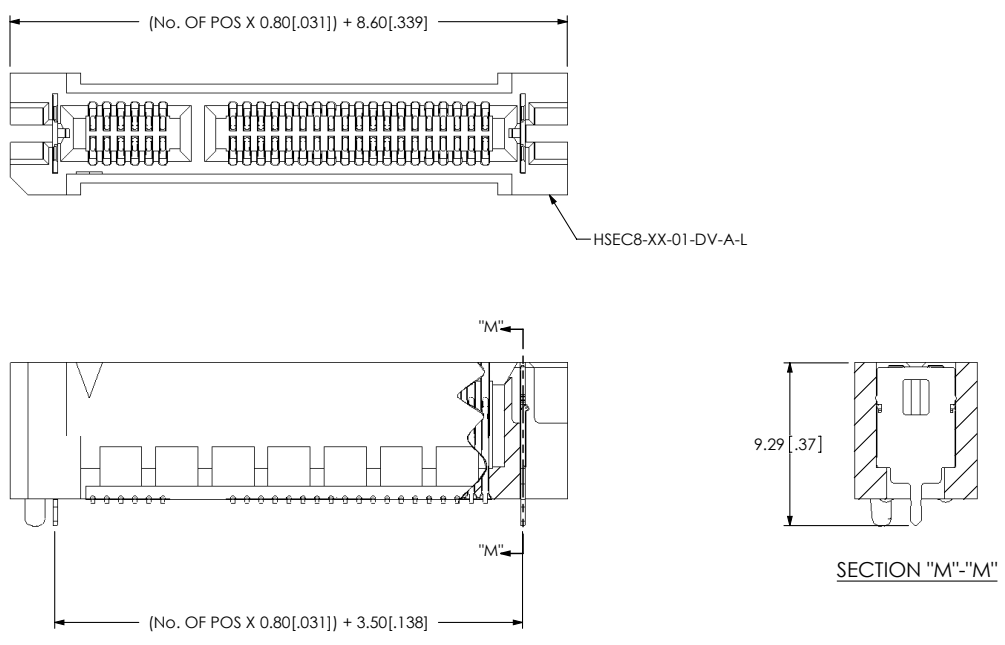



FIG 9
 **L2: ECDP LATCHING OPTION
 (AVAILABLE IN **26, **50, **74 & **98 POS ONLY)
 NOT AVAILABLE FOR -GR TYPE USE
 (SAME AS FIG. 2, UNLESS OTHERWISE STATED)
 (SHOWN: HSEC8-137-01-XX-DV-A-L2)
 (** = AVAILABLE ONLY WITH -01 CARD THICKNESS)

<p>PROPRIETARY NOTE THIS DOCUMENT CONTAINS INFORMATION CONFIDENTIAL AND PROPRIETARY TO SAMTEC, INC. AND SHALL NOT BE REPRODUCED OR TRANSFERRED TO OTHER DOCUMENTS OR DISCLOSED TO OTHERS OR USED FOR ANY PURPOSE OTHER THAN THAT WHICH IT WAS OBTAINED WITHOUT THE EXPRESSED WRITTEN CONSENT OF SAMTEC, INC.</p> <p>DO NOT SCALE DRAWING</p> <p>SHEET SCALE: 3:1</p>	 520 PARK EAST BLVD, NEW ALBANY, IN 47150 PHONE: 812-944-6733 FAX: 812-948-5047 e-Mail: info@SAMTEC.com code 55322	
	DESCRIPTION: 0.8mm HIGH SPEED ASSEMBLY	
	DWG. NO. HSEC8-1XXX-XX-XX-DV-X-XX	
	BY: BRATCHER 01/24/03	SHEET 7 OF 7

F:\dwg\misc\mktg\HSEC8-1XXX-XX-XX-DV-X-XX-MKT.SLDDRW