

Tous droits strictement réservés. Reproduction ou communication à des tiers interdite sous quelque forme que ce soit sans autorisation écrite du propriétaire. Property of FCI. Droits de reproduction FCI.

All rights strictly reserved. Reproduction or issue to third parties in any form whatever is not permitted without written authority from the proprietor. Property of FCI. Copyright FCI.

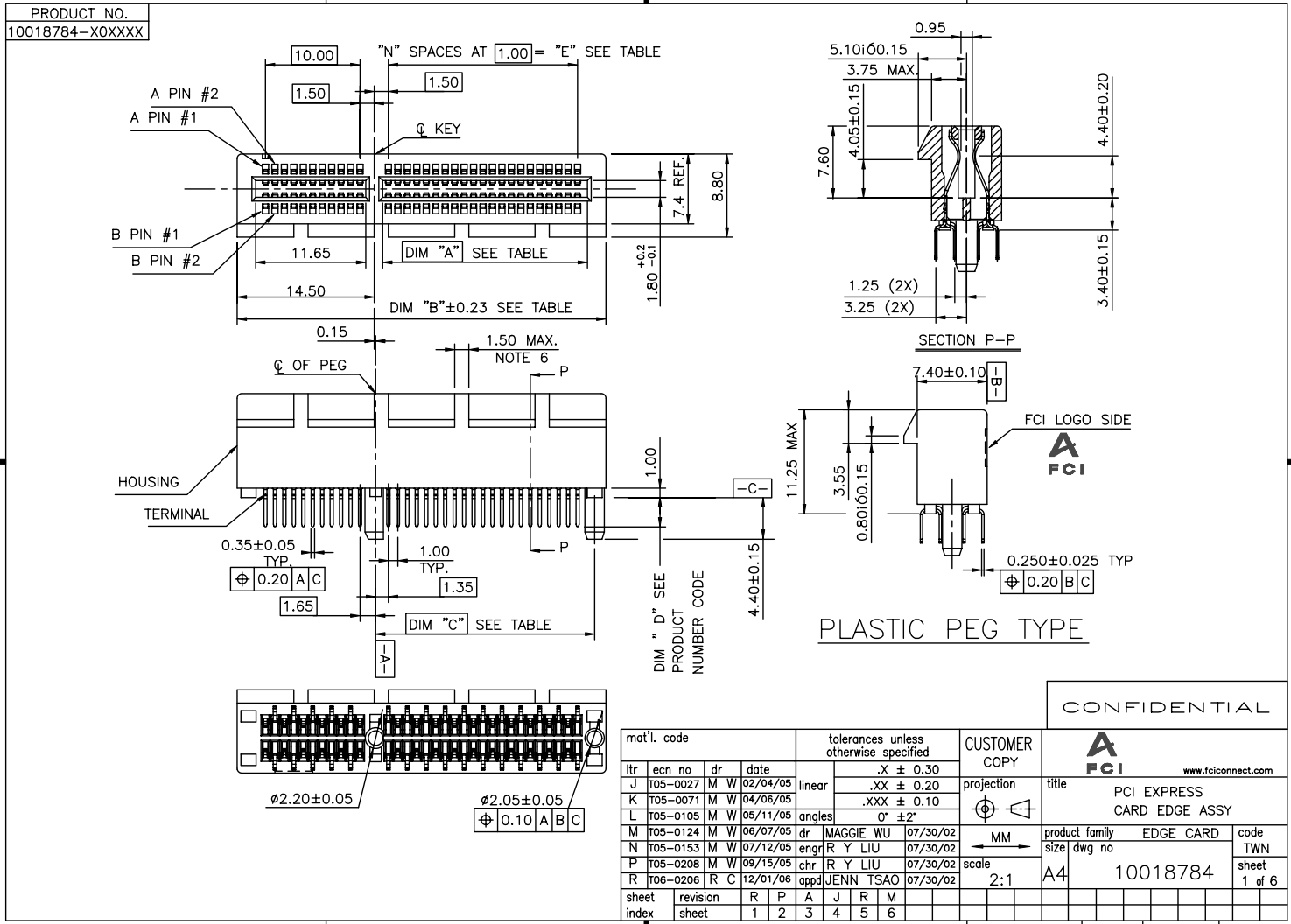

CONFIDENTIAL

mat'l. code				tolerances unless otherwise specified		CUSTOMER COPY		FCI www.fciconnect.com	
itr	ecn no	dr	date	linear	.X ± 0.30	projection	title	PCI EXPRESS CARD EDGE ASSY	
J	T05-0027	M	W 02/04/05		.XX ± 0.20	MM	product family	EDGE CARD	code
K	T05-0071	M	W 04/08/05		.XXX ± 0.10		size	dwg no	TWN
L	T05-0105	M	W 05/11/05	angles	0° ±2°	scale	A4	10018784	sheet 1 of 6
M	T05-0124	M	W 06/07/05	dr	MAGGIE WU 07/30/02				
N	T05-0153	M	W 07/12/05	engr	R Y LIU 07/30/02				
P	T05-0208	M	W 09/15/05	chr	R Y LIU 07/30/02				
R	T06-0206	R	C 12/01/06	appd	JENN TSAO 07/30/02				
sheet index	revision	R	P	A	J	R	M		
	sheet	1	2	3	4	5	6		

ACAD PDM: Rev:R STATUS Released 22526 Formed Jun 28, 2010

Tous droits strictement réservés. Reproduction ou communication a des tiers interdite sous quelque forme que ce soit sans autorisation écrite du propriétaire. Property of FCI. Droits de reproduction FCI.

All rights strictly reserved. Reproduction or issue to third parties in any form whatever is not permitted without written authority from the proprietor. Property of FCI. Copyright FCI.

PRODUCT NO.
10018784-X1XXXX

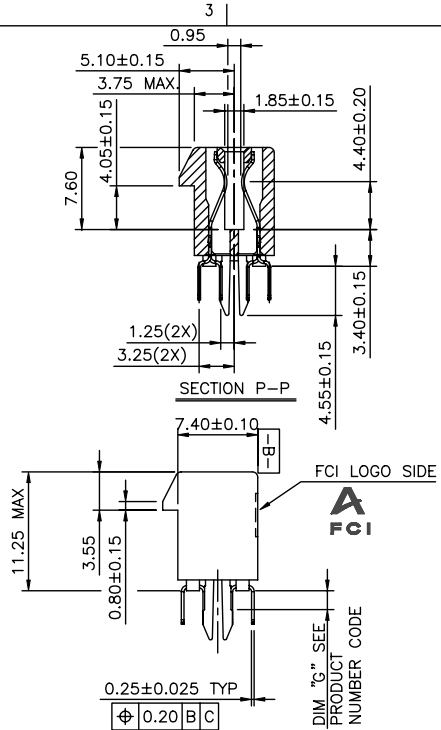
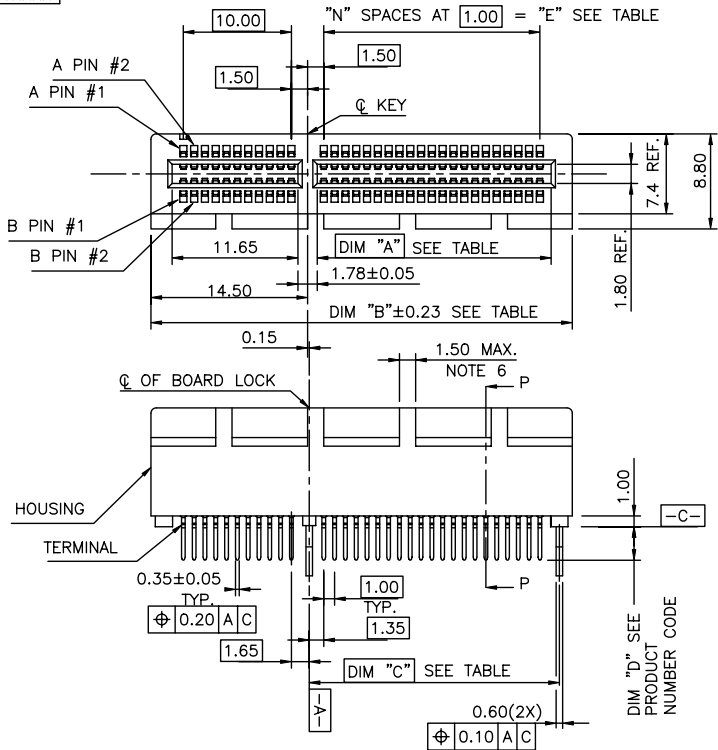

METAL BOARD LOCKS TYPE

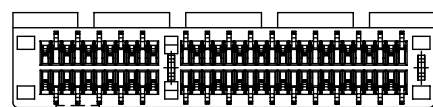

CONFIDENTIAL

mat'l. code		tolerances unless otherwise specified		CUSTOMER COPY		FCI www.fciconnect.com	
ltr	ecn no	dr	date	linear	.X ± 0.30	projection	title
P					.XX ± 0.20		PCI EXPRESS CARD EDGE ASSY
					.XXX ± 0.10		product family
				angles	0° ± 2°	MM	code
				dr	MAGGIE WU 07/30/02	scale	TWN
				engr	R Y LIU 07/30/02	2:1	sheet
				chr	R Y LIU 07/30/02		2 of
				appd	JENN TSAO 07/30/02		
sheet index	revision sheet						

1 | 2

3 |

4

ACAD

PDM: Rev:R

STATUS Released
cage code 22526
Formed Jun 28, 2010

Tous droits strictement réservés. Reproduction ou communication a des tiers interdite sous quelque forme que ce soit sans autorisation écrite du propriétaire. Property of FCI. Droits de reproduction FCI.

All rights strictly reserved. Reproduction or issue to third parties in any form whatever is not permitted without written authority from the proprietor. Property of FCI. Copyright FCI.

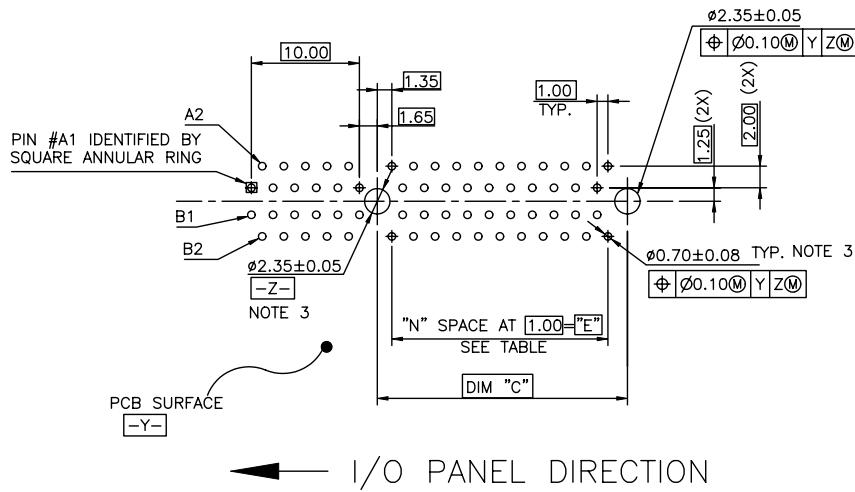

RECOMMENDED FOOTPRINT

CONFIDENTIAL

mat'l. code				tolerances unless otherwise specified		CUSTOMER COPY		FCI		www.fciconnect.com	
ltr	ecn no	dr	date	linear	.X ±	projection		title			
A					.XX ±			PCI EXPRESS CARD EDGE ASS'Y			
				angles	.XXX ±			product family	EDGE CARD	code	TWN
				dr	0° ±2°	MM	size	dwg no	sheet	3 of	
				enrg		scale	A4	10018784			
				chr		2:1					
				appd							
sheet index	revision sheet										

1 | 2

ACAD

PDM: Rev:R

STATUS Released

cage code 22526

4 Formed: Jun 28, 2010

Tous droits strictement réservés. Reproduction ou communication a des tiers interdite sous quelque forme que ce soit sans autorisation écrite du propriétaire. Propriété de c FCI. Droits de reproduction FCI.

All rights strictly reserved. Reproduction or issue to third parties in any form whatever is not permitted without written authority from the proprietor. Property of FCI. Copyright FCI.

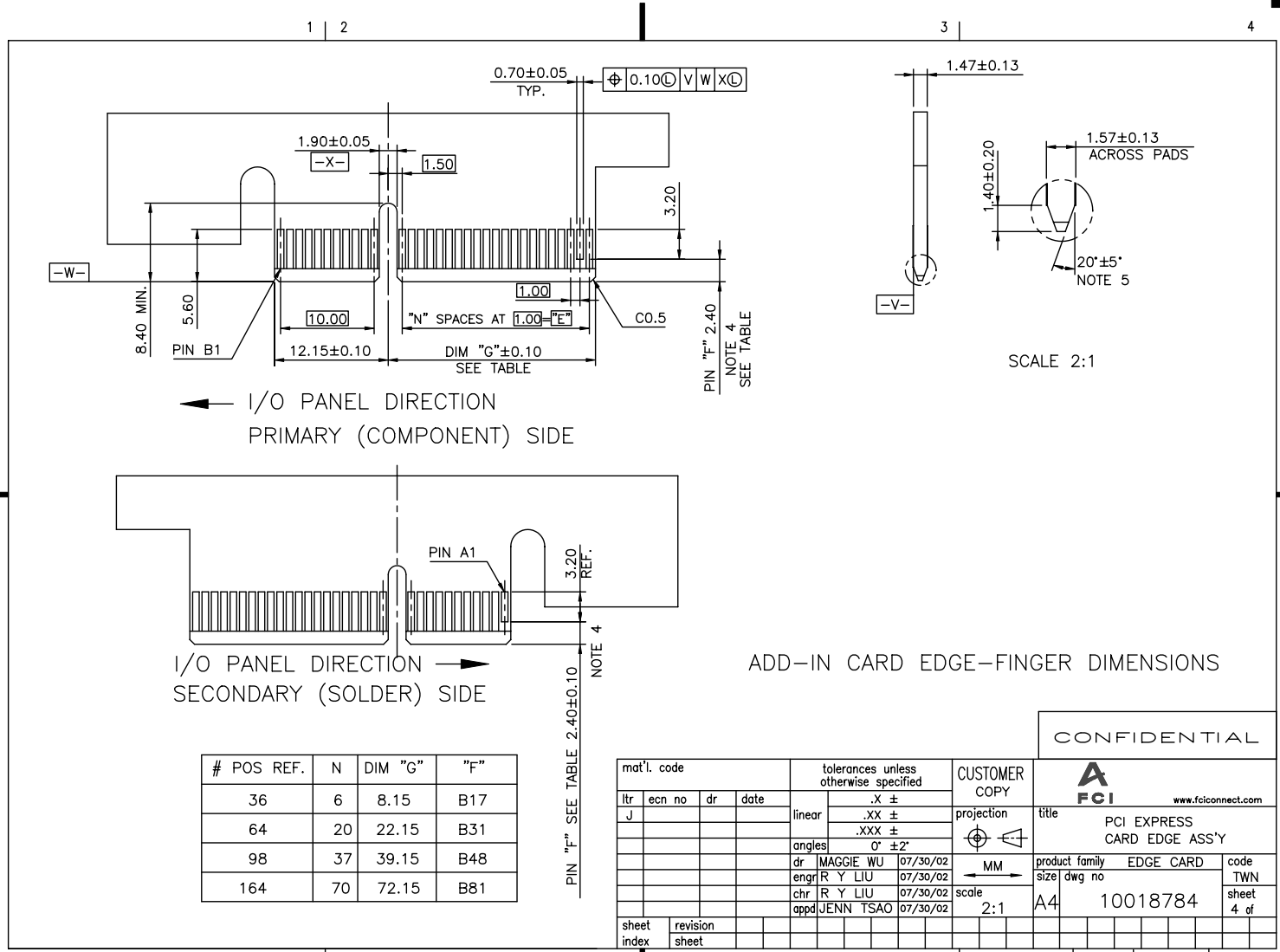

CONFIDENTIAL

mat'l. code		tolerances unless otherwise specified		CUSTOMER COPY		www.fciconnect.com	
ltr	ecn no	dr	date	linear	.X ±	projection	title
J					.XX ±		PCI EXPRESS CARD EDGE ASS'Y
				angles	.XXX ±		product family
					0' ±2'	MM	EDGE CARD
		dr	MAGGIE WU	07/30/02		scale	code
		enrg	R Y LIU	07/30/02		2:1	TWN
		chr	R Y LIU	07/30/02			size
		appd	JENN TSAO	07/30/02			dwg no
sheet index	revision sheet						A4
							10018784
							sheet 4 of

NOTES:

1.MATERIAL:
 HOUSING: NYLON, GLASS FILLED UL94V-0 RATE, SUITABLE FOR WAVE SOLDERING.
 TERMINAL: COPPER ALLOY
 PLATING: 50u" NICKEL UNDERPLATE ALL OVER
 CONTACT AREA PLATING - SEE PRODUCT NUMBER CODE
 SOLDER TAIL: TIN/LEAD (90/10) - SEE PRODUCT NUMBER CODE 100u" MIN. OVER 50u" NICKEL
 METAL BOARD LOCKS: COPPER ALLOY
 FINISH: 100u" TIN/LEAD (90/10) OVER 50u" NICKEL UNDERPLATE SEE PRODUCT NUMBER CODE

2.PRODUCT SPECIFICATION: GS-12-233

③THE HORIZONTAL AXIS FOR THE HOLE PATTERN IS ESTABLISHED BY A LINE THROUGH THE CENTER OF THE TWO #2.35 HOLES. THE VERTICAL AXIS IS 90° TO THE HORIZONTAL AXIS, THROUGH THE CENTER OF DATUM Z.

④NO TIE BAR PERMITTED FROM CARD EDGE TO LEADING EDGE OF PAD FOR PINS A1 AND PIN NUMBERS "F".

⑤CHAMFER EDGES MUST BE FREE OF CUTTING BURRS.

⑥FREQUENCY & LOCATION AT SUPPLIER DISCRETION. RIDGE MAY BE CONTINUOUS WITH NO BREAKS.

7.RoHS COMPATIBLE PRODUCT SPECIFICATIONS

a - PLATING:

- "LF" MEANS THE PRODUCT IS LEAD-FREE, 2um MINIMUM MATTE TIN OVER 1.27um MINIMUM NICKEL UNDERPLATE.

b - MANUFACTURING PROCESS COMPATIBILITY

- THE HOUSING WILL WITHSTAND EXPOSURE TO 260°C±5°C SOLDER BATH TEMPERATURE FOR 5 SECONDS IN A WAVE SOLDER APPLICATION WITH A 1.6mm MIN THICK CIRCUIT BOARD.
 - THE HOUSING WILL WITHSTAND EXPOSURE TO 240°C±5°C SOLDER BATH TEMPERATURE FOR 5 SECONDS IN A WAVE SOLDER APPLICATION WITH A 1.6mm MIN THICK CIRCUIT BOARD.(For 10018784-X 0 X X X X(X X) options)

CONNECTOR	# POS	REF. N	DIM "A"	DIM "B"	DIM "C"	"E"
1 PORT	36	6	7.65	25.00	9.15	6.00
4 PORT	64	20	21.65	39.00	23.15	20.00
8 PORT	98	37	38.65	56.00	40.15	37.00
16 PORT	164	70	71.65	89.00	73.15	70.00

PRODUCT NUMBER CODE
 10018784-X X X X X X X X X X

HOUSING COLOR OPTIONS

- 0-WHITE
- 1-BLACK

PEGS OPTIONS

- 0-PLASTIC PEGS
- 1-METAL BOARD LOCKS

TERMINAL PLATING OPTIONS

- 0-50u" Ni UNDERPLATE
30u" Au CONTACT AREA
100u" TIN TAIL AREA ----- COMPATIBLE RoHS
- 1-50u" Ni UNDERPLATE
15u" Au CONTACT AREA
100u" TIN TAIL AREA ----- COMPATIBLE RoHS
- 2-50u" Ni UNDERPLATE
GOLD FLASH CONTACT AREA
100u" TIN TAIL AREA ----- COMPATIBLE RoHS
- 3-50u" Ni UNDERPLATE
30u" Au CONTACT AREA
100u" TIN/LEAD TAIL AREA ----- INCOMPLIANT RoHS
- 4-50u" Ni UNDERPLATE
15u" Au CONTACT AREA
100u" TIN/LEAD TAIL AREA ----- INCOMPLIANT RoHS
- 5-50u" Ni UNDERPLATE
GOLD FLASH CONTACT AREA
100u" TIN/LEAD TAIL AREA ----- INCOMPLIANT RoHS

LEAD FREE OPTION

LEAVE BLANK FOR TERMINAL PLATING 3,4,5
 "LF" FOR TERMINAL PLATING OPTION 0,1,2

POS OPTIONS

- 0-36
- 1-64
- 2-98
- 3-164

TAIL LENGTH OPTIONS

DIM "D"	PCB THICKNESS	BOARD LOCKS DIM"G"
0 2.30 ^{+0.25} _{-0.13}	1.56±0.10	1.70±0.15
1 3.10 ^{+0.25} _{-0.13}	2.36±0.10	2.50±0.15

PACKAGING OPTIONS

T-TRAY PACKAGING
 M-TRAY PACKAGING & MYLAR TAPE FOR PICK-N-PLACE. SEE FIGURE 1

CONFIDENTIAL

- 0-50u" Ni UNDERPLATE
30u" Au CONTACT AREA
100u" TIN TAIL AREA ----- COMPATIBLE RoHS
- 1-50u" Ni UNDERPLATE
15u" Au CONTACT AREA
100u" TIN TAIL AREA ----- COMPATIBLE RoHS
- 2-50u" Ni UNDERPLATE
GOLD FLASH CONTACT AREA
100u" TIN TAIL AREA ----- COMPATIBLE RoHS
- 3-50u" Ni UNDERPLATE
30u" Au CONTACT AREA
100u" TIN/LEAD TAIL AREA ----- INCOMPLIANT RoHS
- 4-50u" Ni UNDERPLATE
15u" Au CONTACT AREA
100u" TIN/LEAD TAIL AREA ----- INCOMPLIANT RoHS
- 5-50u" Ni UNDERPLATE
GOLD FLASH CONTACT AREA
100u" TIN/LEAD TAIL AREA ----- INCOMPLIANT RoHS

mat'l. code				tolerances unless otherwise specified				CUSTOMER COPY		FCI www.fciconnect.com	
ltr	ecn no	dr	date	linear	.X ±	projection	title	PCI EXPRESS CARD EDGE ASS'Y			
R					.XX ±		product family	EDGE CARD		code	
				angles	.XXX ±		size	dwg no		TWN	
				dr	0° ±2'	MM	A4	10018784		sheet	5 of
				enrg		scale	1:1				
				chr	MAGGIE WU 07/30/02						
				app	R Y LIU 07/30/02						
					JENN TSAO 07/30/02						
sheet index	revision sheet										

Tous droits strictement reserves. Reproduction ou communication a des tiers interdite sous quelque forme que ce soit sans autorisation écrite du propriétaire. Property of FCI. Droits de reproduction FCI.

All rights strictly reserved. Reproduction or issue to third parties in any form whatever is not permitted without written authority from the proprietor. Property of FCI. Copyright FCI.

Tous droits strictement réservés. Reproduction ou communication a des tiers interdite sous quelque forme que ce soit sans autorisation écrite du propriétaire. Propriété de c FCI. Droits de reproduction FCI.



All rights strictly reserved. Reproduction or issue to third parties in any form whatever is not permitted without written authority from the proprietor. Property of FCI. Copyright FCI.

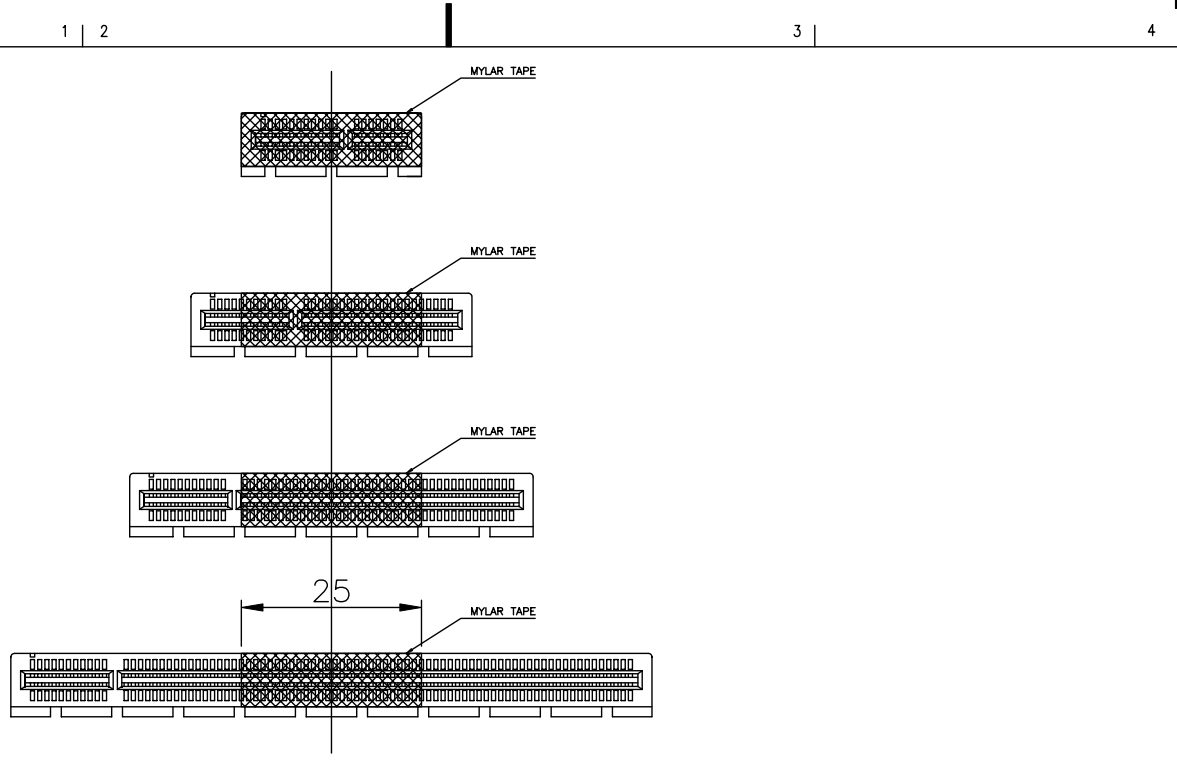

FIGURE 1

CONFIDENTIAL

mat'l. code				tolerances unless otherwise specified			CUSTOMER COPY		www.fciconnect.com		
ltr	ecn no	dr	date	linear	.X ± 0.25	projection			title		
M					.XX ± 0.13				PCI EXPRESS CARD EDGE ASS'Y		
				angles	.XXX ± 0.05				product family	EDGE CARD	code
				dr	0° ± 2°				size		TWN
				engr		scale	1.5:1		A4	10018784	sheet
				chr	MAGGIE WU 06/07/05						6 of
				enr	R Y LIU 06/07/05						
				chr	R Y LIU 06/07/05						
				appd	JENN TSAO 06/07/05						
sheet index	revision sheet										

ACAD PDM: Rev:R STATUS Released cage code 22526 Formed Jun 28, 2010