

REVISIONS				
REV.	ECO. NO	DESCRIPTION	DATE	BY
A	1516	INITIAL RELEASE	11/12/2007	JH
B	1810	ADD HB TERMINATION, UPDATE LAYOUT	9/25/2008	ASK
C	2130	UPDATE WITHSTANDING VOLTAGE, PCB & DAUGHTER CARD LAYOUTS, CORRECT S621, BOARD LOCK 3.200" (WAS 3.191"), .150" (WAS .140"), REMOVE F & H MTL	4/15/2010	JH

PART NUMBER CODING

B60D -S621

MATERIAL (INSULATOR/CONTACT)

- R = BLACK, PPS/PHOSPHOR BRONZE**
OPERATING TEMP: -65°C TO +125°C
PROCESSING TEMP: 260°C FOR 120 SECS MAX
- G = BLACK, PA9T/PHOSPHOR BRONZE**
OPERATING TEMP: -65°C TO +125°C
PROCESSING TEMP: 260°C FOR 120 SECS MAX
- A = BLACK, PPS/BERYLLIUM COPPER**
OPERATING TEMP: -65°C TO +150°C
PROCESSING TEMP: 260°C FOR 120 SECS MAX
- J = BLACK, PA9T/BERYLLIUM COPPER**
OPERATING TEMP: -65°C TO +150°C
PROCESSING TEMP: 260°C FOR 120 SECS MAX
(CONSULT FACTORY FOR OTHER MATERIALS)

MOUNTING STYLE

- S = ϕ .125 SIDE MOUNTING (PAGE 2)
- D = FLUSH MOUNTING (PAGE 2)
- N = NO MOUNTING EARS (PAGE 2)
- T = #4-40 THREADED INSERTS (PAGE 2)
- R = METAL BOARD LOCK (PAGE 2)

TERMINATION TYPE

- HA = .100" [2.54 mm] STAGGERED DIP SOLDER, .050" CENTERS
- HB = .170" [4.32 mm] STAGGERED DIP SOLDER, .050" CENTERS

PLATING

ALL PLATINGS ARE LEAD FREE AND HAVE .000050" NICKEL UNDERPLATE

CONTACT SURFACE TERMINATION

- B = .000010" GOLD .000100" PURE TIN, MATTE
- C = .000030" GOLD .000100" PURE TIN, MATTE

NOTES:

1. MATERIALS:
 - A. INSULATOR: SEE PART NUMBER CODING.
 - B. CONTACT: SEE PART NUMBER CODING.
 - C. PLATING: SEE PART NUMBER CODING.
2. THERMAL:
 - A. OPERATING TEMPERATURE: SEE PART NUMBER CODING.
 - B. PROCESSING TEMP: SEE PART NUMBER CODING.
 - C. UL FLAMMABILITY RATING: 94V-0.
3. ELECTRICAL:
 - A. DIELECTRIC WITHSTANDING VOLTAGE: MATED CONNECTOR MUST EXHIBIT NO EVIDENCE OF BREAKDOWN, FLASHOVER, OR DETERIORATION FROM AN APPLIED VOLTAGE OF 300 VAC (VALUE HAS BEEN DE-RATED), RMS 60 HZ WHEN TESTED IN ACCORDANCE WITH MIL-STD-1344, METHOD 3001. DURATION OF APPLICATION SHALL BE 5 SECS MIN.
 - B. INSULATION RESISTANCE (IR): 5,000 MEGOHMS @ 500 VOLTS \pm 10% WHEN TESTED IN ACCORDANCE WITH MIL-STD-1344, METHOD 3003 @ 25°C.
 - C. CONTACT RESISTANCE: 30 MILLIOHM MAX.
 - D. CURRENT RATING: 1 AMP PER CONTACT.
4. MECHANICAL:
 - A. CONNECTOR IDENTIFICATION: THE PART SHALL BE MARKED WITH A LOT CODE AS A MINIMUM. IF SPACE PERMITS ALSO MARK PART WITH SULLINS WEBSITE, AND PART NUMBER.
 - B. DURABILITY: 500 CYCLES MINIMUM.
 - C. BOARD THICKNESS ACCOMMODATED: .062 \pm .008"
 - D. BOARD INSERTION FORCE: 16 OZ MAX PER CONTACT PAIR WHEN USING A .062" TEST BLADE. INTERNAL INSPECTION TO BE PER SULLIN'S WORK INSTRUCTION W17.3-01.
 - E. BOARD WITHDRAWAL FORCE: 1 OUNCE MINIMUM PER CONTACT PAIR USING .062" PCB.
5. MODIFICATION:
 - F. CARDSLOT BARRIERS WITHOUT GUIDEPOSTS, FOR PCI 32 BIT 5 VOLT 60 (11/49) POSITION CONNECTOR.

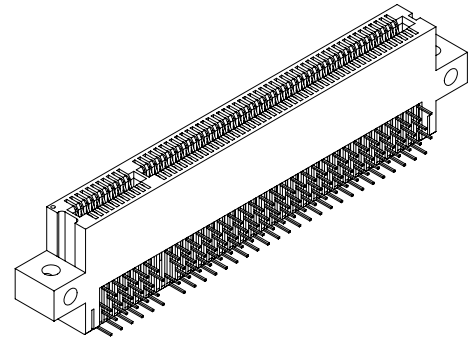

CUSTOMER COPY



RoHS COMPLIANT

UNLESS OTHERWISE SPECIFIED: DIMENSIONS ARE IN INCHES(MM)		DATE	NAME
TOLERANCES: ANGULAR: \pm .30° XX = \pm .02 [.508] XXX = \pm .005 [.127] XXXX = \pm .0005 [.0127] SURFACE FINISH: 63 Ra REMOVE ALL BURRS AND SHARP EDGES .010 MAX		3/11/2007	V. JARA
THE INFORMATION HEREIN CONTAINS PROPRIETARY INFORMATION OF SULLINS ELECTRONICS AND IS NOT TO BE REPRODUCED, COPIED, OR DISCLOSED TO OTHERS FOR ANY PURPOSE EXCEPT AS SPECIFICALLY AUTHORIZED IN WRITING BY AN OFFICER OF SULLINS ELECTRONICS.		DESCRIPTION EDGE CARD, .050 CC, RAB	
PART NUMBER B60D -S621, (DHA, DHB)		SIZE	DWG. NO.
INTERPRET DIMENSIONS AND GEOMETRIC TOLERANCING PER: ANSI Y14.5M-1994		C	C10680
SCALE: 2:1		REV	SHEET 1 OF 3
			C

FIRST POSITION INDICATOR

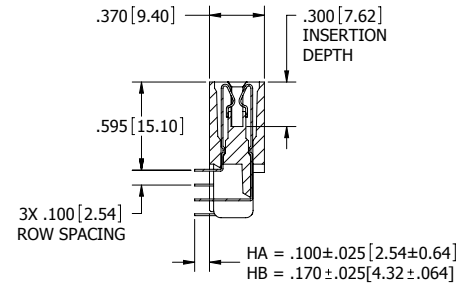
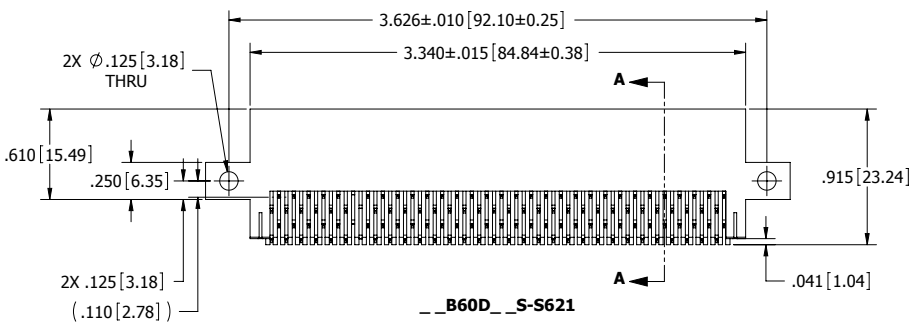
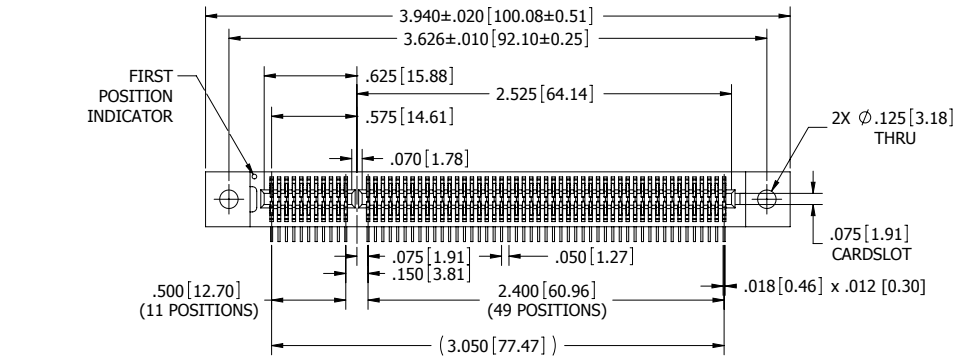

SECTION A-A

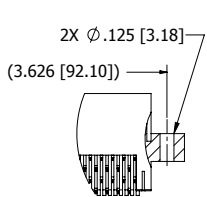

__B60D__D-S621

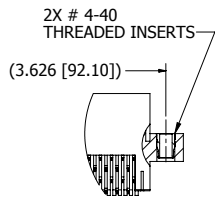

__B60D__T-S621

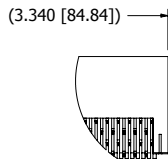

__B60D__N-S621

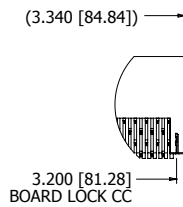

__B60D__R-S621

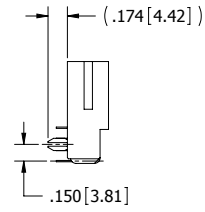

MOUNTING STYLES



RoHS COMPLIANT

UNLESS OTHERWISE SPECIFIED:
 DIMENSIONS ARE IN INCHES[MM]
 TOLERANCES:
 ANGULAR: ±.30°
 XX = ±.02 [508]
 XXX = ±.005 [127]
 XXXX = ±.0005 [127]
 SURFACE FINISH: 63 Ra
 REMOVE ALL BURRS AND SHARP EDGES .010 MAX
 INTERPRET DIMENSIONS AND GEOMETRIC TOLERANCING PER: ANSI Y14.5M-1994

DATE	NAME
3/1/2007	V. JARA

SULLINS CONNECTOR SOLUTIONS	
DESCRIPTION	EDGE CARD, .050 CC, RAB
PART NUMBER	B60D __-S621, (DHA, DHB)
SIZE	C
DWG. NO.	C10680
SCALE	2:1
REV	C
SHEET 2 OF 3	

CUSTOMER COPY

8 7 6 5 4 3 2 1

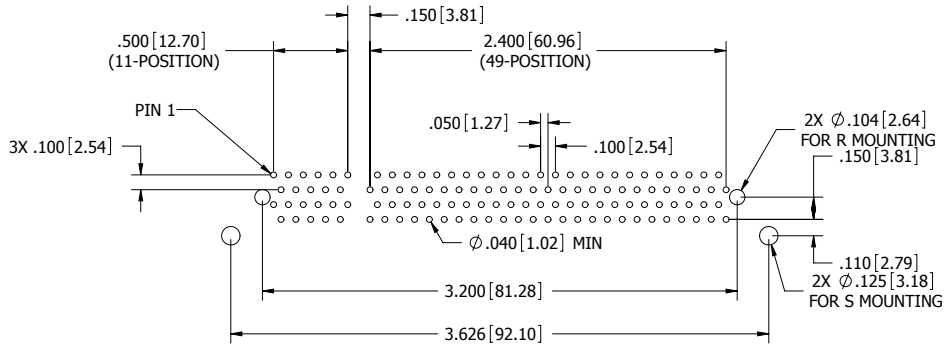

RECOMMENDED PCB LAYOUT, COMPONENT SIDE

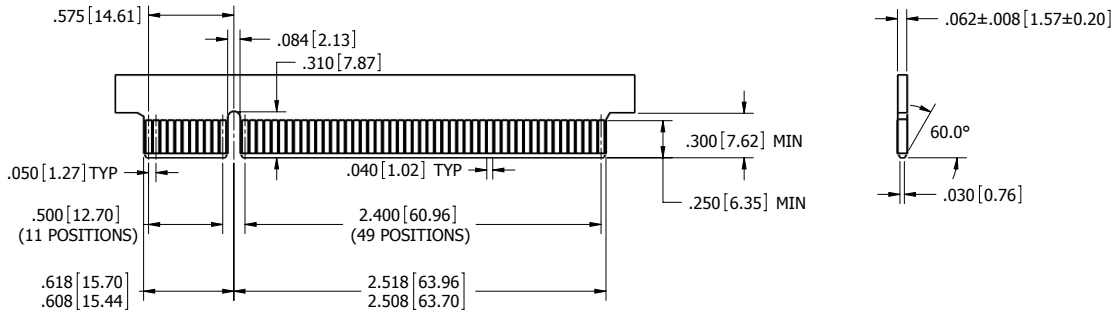
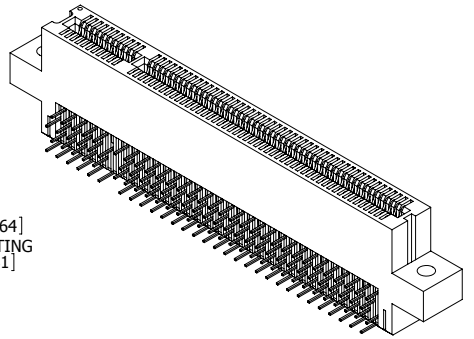

DAUGHTER CARD LAYOUT

CUSTOMER COPY



UNLESS OTHERWISE SPECIFIED:
 DIMENSIONS ARE IN INCHES[MM]
 TOLERANCES:
 ANGULAR: ± .31°
 XX = ± .02 [.508]
 XXX = ± .005 [.127]
 .XXXX = ± .0005 [.0127]
 SURFACE FINISH: 63 Ra
 REMOVE ALL BURRS AND SHARP EDGES .010 MAX
 INTERPRET DIMENSIONS AND GEOMETRIC
 TOLERANCING
 PER: ANSI Y14.5M-1994

DATE	NAME	
3/1/2007	V. JARA	
THE INFORMATION HEREIN CONTAINS PROPRIETARY INFORMATION OF SULLINS ELECTRONICS AND IS NOT TO BE REPRODUCED, COPIED OR DISCLOSED TO OTHERS FOR ANY PURPOSE EXCEPT AS SPECIFICALLY AUTHORIZED IN WRITING BY AN OFFICER OF SULLINS ELECTRONICS.		DESCRIPTION
		EDGE CARD, .050 CC, RAB
PART NUMBER		
B40D		-S621, (DHA, DHB)
SIZE	DWG. NO.	REV
C	C10680	C
SCALE: 2:1		SHEET 3 OF 3