

10 9 8 7 6 5 4 3 2 1

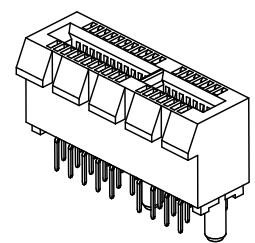

- NOTES:
- 1.MATERIALS:
1-1.HOUSING: SEE TABLE ,GLASS FIBER FILLED UL94V-0, COLOR: SEE TABLE.
 - 1-2.CONTACT: SEE TABLE
 - 2.PLATING:
2-1.CONTACT AREA: GOLD, THICKNESS : SEE TABLE .
2-2.SOLDER TAIL: 100 MICROINCH MIN. TIN PLATING.
2-3.UNDER PLATING: NICKEL PLATING OVERALL.
 - 3.WEEK CODE: XX(YEAR) XXI(WEEK) XI(LOCATION).
 - 4.PRODUCT SPECIFICATION REFER TO PS-87715-200.
 - 5.PACKAGING SPECIFICATION REFER TO PK-87715-207.
 - 6.TEST SUMMARY:REFER TO TS-87715-207.
 - 7.LEAD FREE AND ROHS COMPLIANCE PRODUCT.

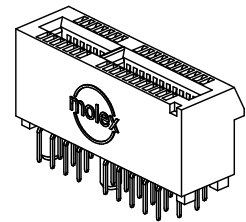
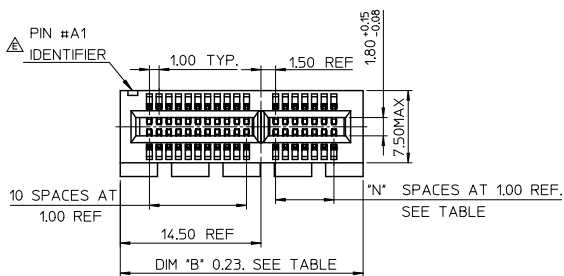
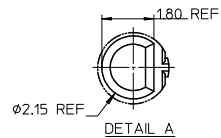
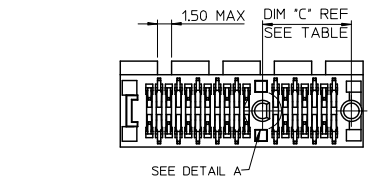
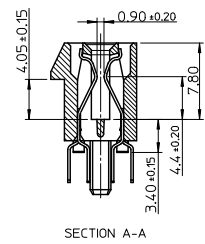
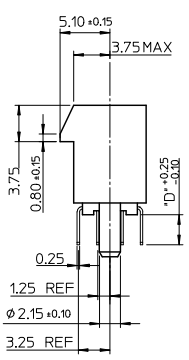
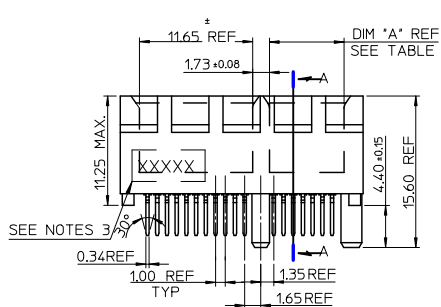

CONNECTOR LINK WIDTH	# POS REF	N	DIM 'A'	DIM 'B'	DIM 'C'
X1	36	6	7.65	25.00	9.15
X4	64	20	21.65	39.00	23.15
X8	98	37	38.65	56.00	40.15
X16	164	70	71.65	89.00	73.15

PCB THK (REF)	DIM 'D'
1.60	2.30
1.58	2.54
2.36	3.00

REVISED EC NO: SH2010-0468 DRAWN: ZHANG 2010/06/15 CHECKED: LUN 2004/07/20 APPROVED: JIANG 2010/07/02 DESCRIPTION	QUALITY SYMBOLS	GENERAL TOLERANCES (UNLESS SPECIFIED)	DIMENSION STYLE	SCALE	DESIGN UNITS	THIRD ANGLE PROJECTION
	▽=0	mm INCH	MM ONLY	METRIC	⊙	
	▽=0	4 PLACES ± --- ± ---	DRAWN BY DATE	TITLE		
	▽=0	3 PLACES ± --- ± ---	TOM 2004/07/20	PCI EXPRESS EDGE CARD CONNECTOR (LEAD FREE VERSION)		
	2 PLACES ± 0.25 ± ---	CHECKED BY DATE	MOLEX INCORPORATED			
	1 PLACE ± 0.25 ± ---	ALLEN LIN 2004/07/20	MATERIAL NO. DOCUMENT NO. SHEET NO.			
	ANGULAR ± 3 °	APPROVED BY DATE	SEE SHEET 4 SD-87715-207 1 OF 4			
		WILSON 2004/07/20	THIS DRAWING CONTAINS INFORMATION THAT IS PROPRIETARY TO MOLEX INCORPORATED AND SHOULD NOT BE USED WITHOUT WRITTEN PERMISSION			

9 8 7 6 5 4 3 2 1

10 9 8 7 6 5 4 3 2 1

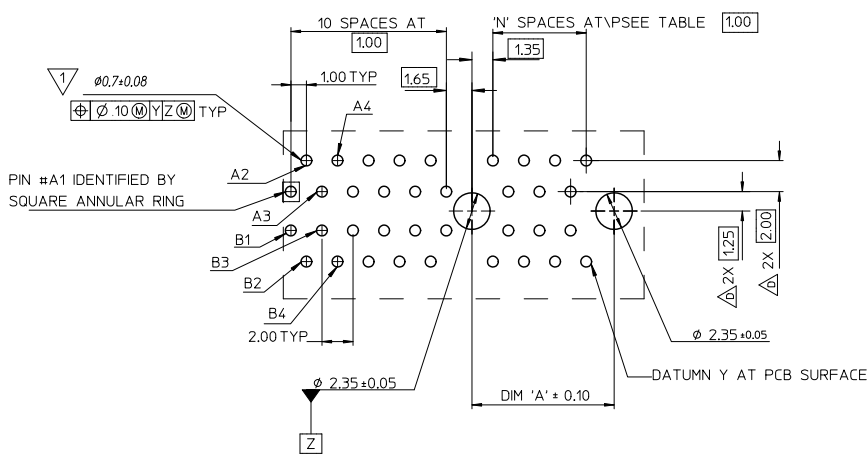

▽ THE HORIZONTAL AXIS FOR THE HOLE PATTERN IS ESTABLISHED BY A LINE THROUGH THE CENTER OF THE TWO $\phi 2.35$ HOLES. THE VERTICAL AXIS IS 90° TO THE HORIZONTAL AXIS, THROUGH THE CENTER OF DATUM Z

CONNECTOR LINK WIDTH	# POS REF	N	DIM 'A'
X1	36	6	9.15
X4	64	20	23.15
X8	98	37	40.15
X16	164	70	73.15

SEE SHEET 1 EC NO: SH2010-0468 DRAWN BY: DRWNRZHANG 2010/06/15 CHECKED BY: CHYKALLEN LIN 2004/07/20 APPROVED BY: APPR: XJ JSONG 2010/07/02	QUALITY SYMBOLS	GENERAL TOLERANCES (UNLESS SPECIFIED)	DIMENSION STYLE	SCALE	DESIGN UNITS	THIRD ANGLE PROJECTION
	▽=0	mm INCH	MM ONLY		METRIC	
	▽=0	4 PLACES ± --- ± ---	DRAWN BY DATE	TITLE		
	▽=0	3 PLACES ± --- ± ---	TOM 2004/07/20	PCI EXPRESS		
	2 PLACES ± 0.25 ± ---	CHECKED BY DATE				
	1 PLACE ± 0.25 ± ---	ALLEN LIN 2004/07/20				
	ANGULAR ± 3°	APPROVED BY DATE				
	DRAFT WHERE APPLICABLE MUST REMAIN WITHIN DIMENSIONS	WILSON 2004/07/20				
		MATERIAL NO.	SEE SHEET 4			
		DOCUMENT NO.				
		SHEET NO.				

tb_frame_A3_P_AM_T
Rev. F 2009/06/18

9 8 7 6 5 4 3 2 1

10 9 8 7 6 5 4 3 2 1

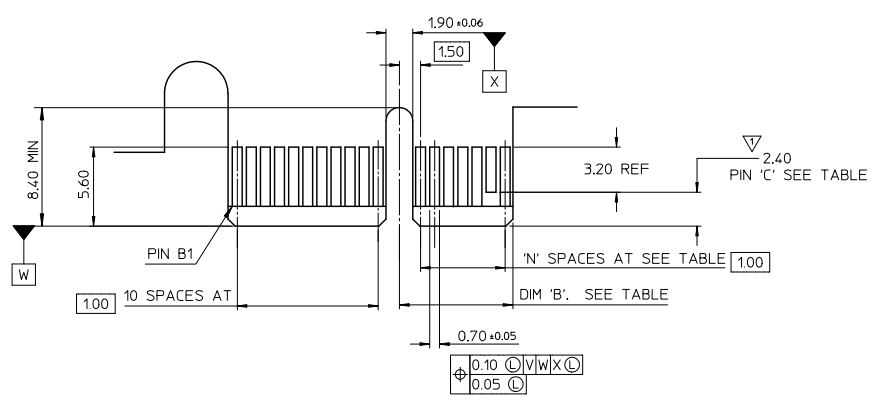

← I/O PANEL DIRECTION

PRIMARY (COMPONENT) SIDE

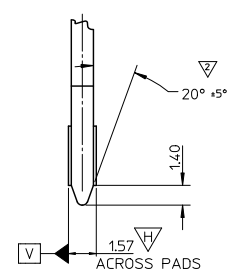

NO TIE BAR PERMITTED FROM CARD EDGE TO LEADING EDGE OF PAD FOR PINS A1 AND 'C'.
 CHAMFER EDGES MUST BE FREE OF CUTTING BURRS.
 3. TOLERANCE: .XX±.13

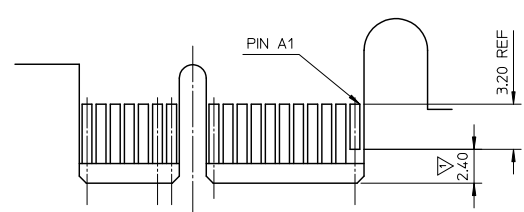

I/O PANEL DIRECTION →

SECONDARY (SOLDER) SIDE

CONNECTOR LINK WIDTH	# POS REF	N	DIM 'B'	'C' △
X1	36	6	8.15	B17
X4	64	20	22.15	B17, B31
X8	98	37	39.15	B17, B31 B48
X16	164	70	72.15	B17, B31 B48, B81

SEE SHEET 1 EC NO: SH2010-0468 DRAWN: ZHANG 2010/06/15 CHECKED: ALLEN LIN 2004/07/20 APPROVED: XIAOSONG 2010/07/02	QUALITY SYMBOLS ▽=0 ▽=0 ▽=0	GENERAL TOLERANCES (UNLESS SPECIFIED)		DIMENSION STYLE MM ONLY		SCALE	DESIGN UNITS	THIRD ANGLE PROJECTION	
		4 PLACES ± --- ± ---	mm	INCH	DRAWN BY	DATE	TITLE	PCI EXPRESS EDGE CARD CONNECTOR (LEAD FREE VERSION)	
		3 PLACES ± 0.25 ± ---			CHECKED BY	DATE	MOLEX INCORPORATED		
		2 PLACES ± 0.25 ± ---			APPROVED BY	DATE	SD-87715-207		
1 PLACE ± 0.25 ± ---			ANGULAR ± 3°		MATERIAL NO.		DOCUMENT NO.	SHEET NO.	
DRAFT WHERE APPLICABLE MUST REMAIN WITHIN DIMENSIONS		SEE SHEET 4		WILSON 2004/07/20		3 OF 4			

ib_frame_A3_P_AM_T
 Rev. F 2009/06/18

9 8 7 6 5 4 3 2 1

10 9 8 7 6 5 4 3 2 1

MOLEX P/N	CIRCUIT SIZE	HOUSING MATERIAL	HOUSING COLOR	TERMINAL MATERIAL	CONTACT PLATING	SOLDER TAIL 'D' LENGTH
87715-9001	36	NYLON46	BLACK	PHOSPHOR BRONZE	10 MICROINCH	2.54
87715-9003					GOLD FLASH	3.00
87715-9004					10 MICROINCH	
87715-9007					GOLD FLASH	2.30
87715-9008					15 MICROINCH	

MOLEX P/N	CIRCUIT SIZE	HOUSING MATERIAL	HOUSING COLOR	TERMINAL MATERIAL	CONTACT PLATING	SOLDER TAIL 'D' LENGTH
87715-9100	64	NYLON46	BLACK	PHOSPHOR BRONZE	GOLD FLASH	2.54
87715-9101					10 MICROINCH	
87715-9102					15 MICROINCH	
87715-9103					GOLD FLASH	3.00
87715-9104					10 MICROINCH	
87715-9105					15 MICROINCH	
87715-9106					30 MICROINCH	2.54
87715-9107					GOLD FLASH	2.30
87715-9108					15 MICROINCH	
87715-9109					30 MICROINCH	3.00

MOLEX P/N	CIRCUIT SIZE	HOUSING MATERIAL	HOUSING COLOR	TERMINAL MATERIAL	CONTACT PLATING	SOLDER TAIL 'D' LENGTH
87715-9200	98	NYLON46	BLACK	PHOSPHOR BRONZE	GOLD FLASH	2.54
87715-9201					10 MICROINCH	
87715-9202					15 MICROINCH	
87715-9203					GOLD FLASH	3.00
87715-9204					10 MICROINCH	
87715-9205					15 MICROINCH	
87715-9206					30 MICROINCH	2.54
87715-9207					GOLD FLASH	2.30
87715-9208					15 MICROINCH	
87715-9209					30 MICROINCH	3.00

MOLEX P/N	CIRCUIT SIZE	HOUSING MATERIAL	HOUSING COLOR	TERMINAL MATERIAL	CONTACT PLATING	SOLDER TAIL 'D' LENGTH
87715-9602	98	NYLON46	BLACK	BRASS	15 MICROINCH	2.54

MOLEX P/N	CIRCUIT SIZE	HOUSING MATERIAL	HOUSING COLOR	TERMINAL MATERIAL	CONTACT PLATING	SOLDER TAIL 'D' LENGTH
87715-9301	164	NYLON46	BLACK	PHOSPHOR BRONZE	10 MICROINCH	2.54
87715-9304					GOLD FLASH	3.00
87715-9307					15 MICROINCH	
87715-9308					15 MICROINCH	2.30

SEE SHEET 1 EC NO: SH2010-0468 DRAWN BY: DRWINRZHANG 2010/06/15 CHECKED BY: CHYKALLEN LIN 2004/07/20 APPROVED BY: APPR: XJISONG 2010/07/02	QUALITY SYMBOLS	GENERAL TOLERANCES (UNLESS SPECIFIED)	DIMENSION STYLE	SCALE	DESIGN UNITS	THIRD ANGLE PROJECTION	
	▽=0	mm INCH	MM ONLY	METRIC			
	▽=0	4 PLACES ± --- ± ---	DRAWN BY: TOM DATE: 2004/07/20	TITLE: PCI EXPRESS EDGE CARD CONNECTOR (LEAD FREE VERSION)			
	▽=0	3 PLACES ± --- ± ---	CHECKED BY: ALLEN LIN DATE: 2004/07/20	APPROVED BY: WILSON DATE: 2004/07/20	MOLEX MOLEX INCORPORATED		
	2 PLACES ± 0.25 ± ---	ANGULAR ± 3°	MATERIAL NO. SEE TABLE	DOCUMENT NO. SD-87715-207	SHEET NO. 4 OF 4		
	1 PLACE ± 0.25 ± ---	DRAFT WHERE APPLICABLE MUST REMAIN WITHIN DIMENSIONS	THIS DRAWING CONTAINS INFORMATION THAT IS PROPRIETARY TO MOLEX INCORPORATED AND SHOULD NOT BE USED WITHOUT WRITTEN PERMISSION				

9 8 7 6 5 4 3 2 1