

## Specification Status: Released

Not to be used for new designs. For new designs please use PESD0603-240.

### BENEFITS

- Suitable for high speed data transmission applications
- Board space savings
- Help to protect sensitive electronic circuits against damage from electrostatic discharge (ESD) events
- Assist equipment to pass IEC 61000-4-2, level 4 testing

### FEATURES

- Thick film technology
- Low capacitance (0.25 pF typical)
- Low clamping voltage
- Capable of withstanding numerous ESD strikes
- Compatible with standard reflow installation procedures
- Bi-directional protection

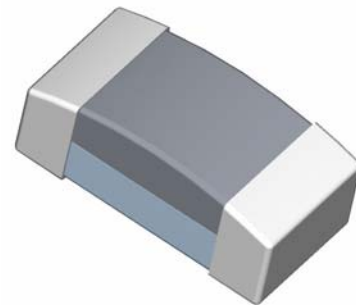

### APPLICATIONS

- Cellular phones

**Caution:** This part is not intended to be used under bias, nor for application with a power bus.

### MATERIALS INFORMATION

ROHS Compliant

Directive 2002/95/EC  
Compliant

ELV Compliant

Directive 2000/53/EC  
Compliant

### PART NUMBERING

Series PESD 0603 - 140 Operating Voltage Designator  
 $14 \times 10^0 = 14V_{DC}$   
EIA Size

The operating voltage is used to measure leakage current @ 1s

## TYPICAL DEVICE RATINGS AND CHARACTERISTICS

	Typical IEC Trigger Voltage <sup>1</sup>	Typical IEC Clamping Voltage <sup>1</sup> after 30ns	Typical TLP Trigger Voltage <sup>2</sup>	Typical TLP Clamping Voltage <sup>2</sup> after 30ns	Typical TLP Clamping Voltage <sup>2</sup> after 60ns	Typical Capacitance @ 1 MHz, 1V <sub>rms</sub>
Symbol	V <sub>T(IEC)</sub>	V <sub>C(IEC)</sub>	V <sub>T(TLP)</sub>	V <sub>C(TLP 30)</sub>	V <sub>C(TLP 60)</sub>	C <sub>p</sub>
Unit	V	V	V	V	V	pF
Value	350	30	320	75	65	0.25

Note 1: IEC61000-4-2, level 4, 8kV contact test method

Note 2: TLP test method at 1000V (refer to graph on next page)

Note 3: PESD0603-140 can be used only in application without DC bias

## GENERAL CHARACTERISTICS

Operating temperature: -55°C ... + 110°C

Storage temperature: -40°C ... + 85°C

ESD voltage capability (tested per IEC 61000-4-2)

- Contact discharge mode: typical 8kV, max 15kV
- Air discharge mode: typical 15kV, max 25kV

ESD pulse withstand: Typically 1,000 pulses (tested per IEC 61000-4-2, level 4, contact method)

## Environmental Specifications

	Thermal Shock	Heat Storage Test	Solderability	Solder Heat	Vibration	Mechanical Shock	Solvent Resistance
Test Conditions	-55°C to 125°C 30min dwell 1000 cycles	110°C, 1000hours	230 °C±5 °C 3±1s, 95% coverage	260 °C, 10s	10 to 50Hz, 60s cycle, 2hrs each in X-Y-Z axis	1500G, 0.5ms, X-Y-Z axis, 3 times	IPA ultrasonic 300s
Pass/Fail Criteria	I <sub>L</sub> ≤10μA	I <sub>L</sub> ≤10μA	I <sub>L</sub> ≤10μA	I <sub>L</sub> ≤10μA	I <sub>L</sub> ≤10μA	I <sub>L</sub> ≤10μA	I <sub>L</sub> ≤10μA

**TYPICAL TRANSMISSION LINE PULSE RESPONSE GRAPH**

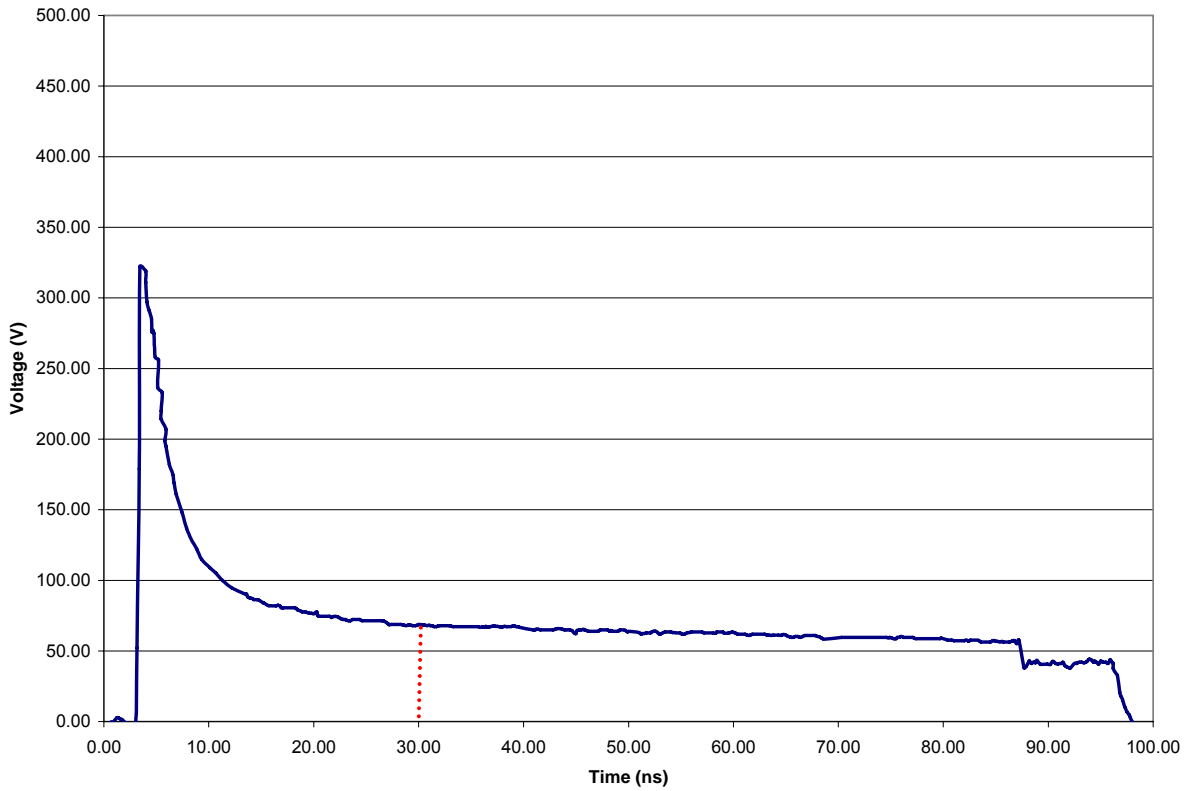

**DIMENSIONS**

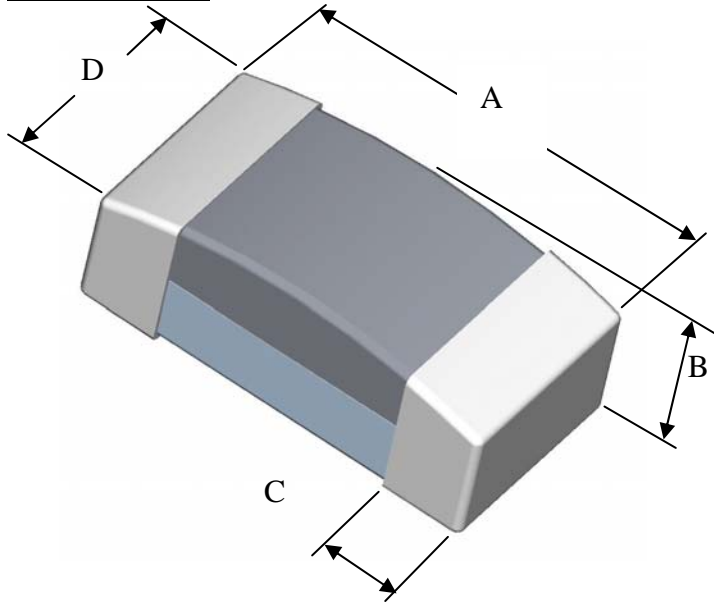

Drawing Not To Scale

	Length A		Height B		Terminal Width C		Width D	
	MIN	MAX	MIN	MAX	MIN	MAX	MIN	MAX
mm:	1.4	1.8	0.4	0.6	0.1	0.5	0.6	0.9
in*:	(0.055)	(0.071)	(0.016)	(0.024)	(0.004)	(0.02)	(0.024)	(0.035)

\*Rounded off approximation

**RECOMMENDED LAND PATTERN:**

Solder thickness 0.15 to 0.2mm

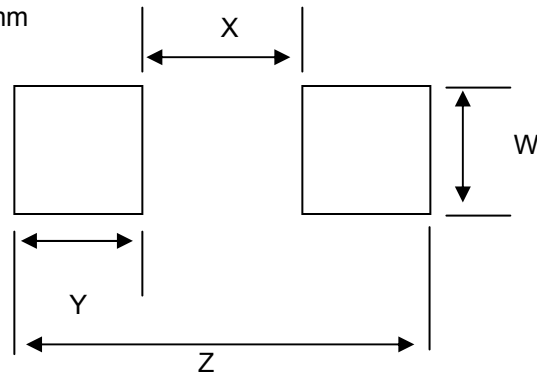

	W		X		Y (Ref)		Z	
	Min	Max	Min	Max	Min	Max	Min	Max
mm:	0.9	1.0	0.5	0.6	1.0	1.1	2.7	2.8
in: *	(0.035)	(0.039)	(0.020)	(0.024)	(0.039)	(0.043)	(0.106)	(0.110)

\*Rounded off approximation.

**SOLDER REFLOW RECOMMENDATIONS:**

A	Temperature ramp up 1	From ambient to Preheating temperature	30s to 60s
B	Preheating	140°C - 160°C	60s to 120s
C	Temperature ramp up 2	From Preheating to Main heating temperature	20s to 40s
D	Main heating	at 200°C at 220°C at 240°C at 260°C	60s ~ 70s 50s ~ 60s 30s ~ 40s 5s ~ 10s
E	Cooling	From main heating temperature to 100°C	max 4°C/s

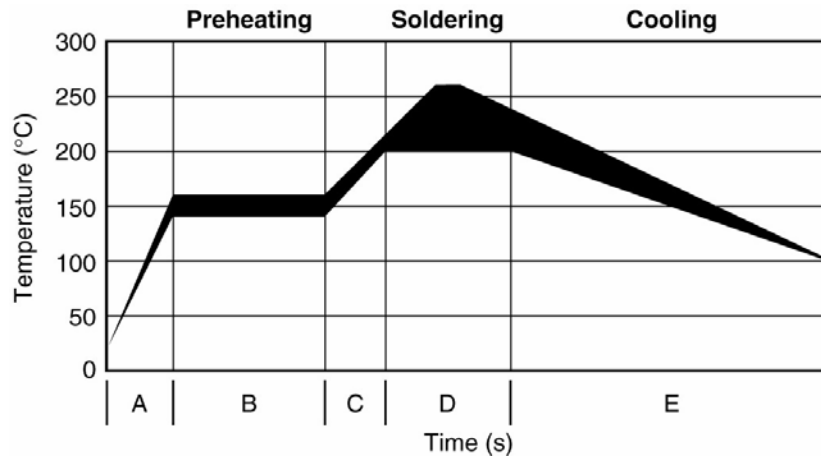

**PACKAGING**

Packaging	Tape & Reel	Standard Box
PESD0603-140	5,000	25,000

**EIA referenced Reel Dimensions for PESD Devices**

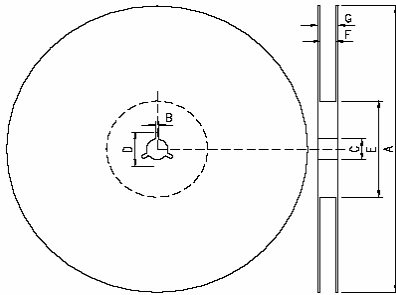

**Reel Dimensions (mm):**

	A	B	C	D	E	F	G
<b>0603 Devices</b>	178.0 ±2.0	2.0 ±0.5	13.0 ±0.5	21.0 ±0.8	62.0 ±1.5	9.0 ±0.5	13.0 ±1.0

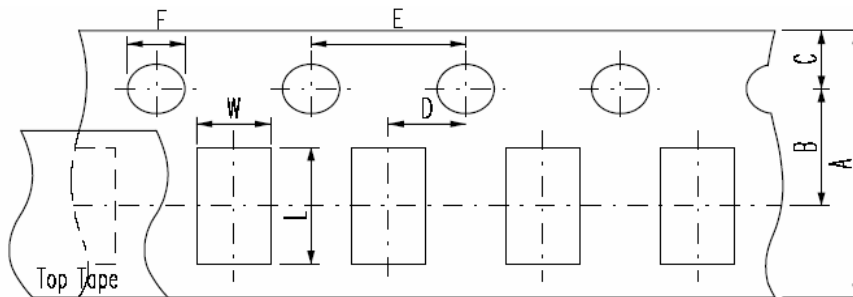

**Carrier Dimensions (mm):**

	A	B	C	D	E	F	L	W	T <sup>1</sup>
<b>0603 Devices</b>	8.0 ±0.3	3.5 ±0.05	1.75 ±0.1	2.0 ±0.05	4.0 ±0.1	1.5 ±0.1	1.9 ±0.2	1.1 ±0.20	0.60 ±0.05

**Product Orientation** – always face up (meaning the substrate is at the bottom), but parts do not have polarity mark.

**Leader & Trailer:** The leader is 180mm in length & consists of empty cavities with sealed cover tape. The trailer is 350mm in length & consists of empty cavities with sealed cover tape.

## POST REFLOW, CLEANING CONDITIONS

A 5% saponifier combined with water during wash.

For Ultrasonic process water temperature should be at 50°C and board should be submerged for a minimum of one minute in the solutions, then rinse and dry.

For in-line washing, the temperature of the water sprayed should be at 110°C, rinse and drying is done in-line.



**Warning: Application Limitations for PESD0603-140. This part is not intended to be used under bias, nor for power bus applications. Users should independently evaluate the suitability of and test each product selected for their own applications**

Information furnished is believed to be accurate and reliable. However, users should independently evaluate the suitability of and test each product selected for their own applications. Tyco Electronics reserves the right to change or update, without notice, any information contained in this publication; to change, without notice, the design, construction, processing, or specification of any product; and to discontinue or limit production or distribution of any product. This publication supersedes and replaces all information previously supplied. Without expressed or written consent by an officer of Tyco Electronics, Tyco Electronics does not authorize the use of any of its products as components in nuclear facility applications, aerospace, or in critical life support devices or systems. Tyco Electronics expressly disclaims all implied warranties regarding the information contained herein, including, but not limited to, any implied warranties of merchantability or fitness for a particular purpose. Tyco Electronics' only obligations are those in the Tyco Electronics Standard Terms and Conditions of Sale and in no case will Tyco Electronics be liable for any incidental, indirect, or consequential damages arising from the sale, resale, use, or misuse of its products.