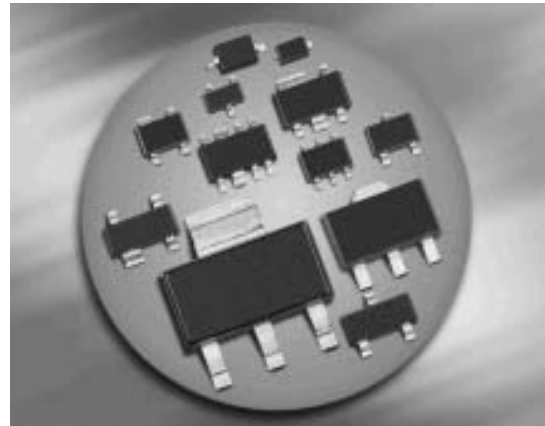
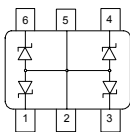
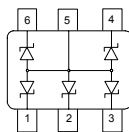

Multi-Channel TVS Diode Array

- ESD / transient protection of data and power lines in 3.3 V / 5 V application according to:
IEC61000-4-2 (ESD): ± 30 KV (contact)
IEC61000-4-4 (EFT): 80 A (5/50 ns)
IEC61000-4-5 (Surge): 10 A (8/20 μ s)
- Working voltage: 5 V (5.3 V max.)
- Low clamping voltage
- Low reverse current $< 5 \mu$ A
- Pb-free (RoHS compliant) package
- Qualified according AEC Q101

Applications

- Uni or bi-directional operation possible (see application example page 5)
- Mobile communication
- Consumer products (STB, MP3, DVD, DSC...)
- LCD displays, camera
- Notebooks and desktop computers, peripherals

ESD5V0S4US

ESD5V0S5US

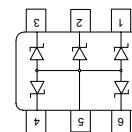
ESD5V0S5US E6727

180° rotated in reel



Type	Package	Configuration	Marking
ESD5V0S4US	SOT363	4 lines, uni-directional	E4s
ESD5V0S5US	SOT363	5 lines, uni-directional	E5s
ESD5V3S5US E6727*	SOT363	5 lines, uni-directional	on request

* Preliminary data

Maximum Ratings at $T_A = 25^\circ\text{C}$, unless otherwise specified

Parameter	Symbol	Value	Unit
ESD contact discharge per diode ¹⁾	V_{ESD}	30	kV
Peak pulse current ($t_p = 8 / 20 \mu\text{s}$) per diode ²⁾	I_{pp}	10	A
Peak pulse power ($t_p = 8 / 20 \mu\text{s}$) per diode	P_{pk}	130	W
Operating temperature range	T_{op}	-55...125	°C
Storage temperature	T_{stg}	-65...150	

Electrical Characteristics at $T_A = 25^\circ\text{C}$, unless otherwise specified

Parameter	Symbol	Values			Unit
		min.	typ.	max.	
Characteristics					
Reverse working voltage	V_{RWM}	-	5	5.3	V
Breakdown voltage $I_{\text{(BR)}} = 1 \text{ mA}$	$V_{\text{(BR)}}$	5.7	6.7	7.7	
Reverse current $V_{\text{R}} = 3.3 \text{ V}$ $V_{\text{R}} = 5 \text{ V}$	I_{R}	-	-	1	μA
		-	-	5	
Clamping voltage (positive transients) $I_{\text{PP}} = 1 \text{ A}, t_p = 8/20 \mu\text{s}^2)$ $I_{\text{PP}} = 10 \text{ A}, t_p = 8/20 \mu\text{s}^2)$	V_{CL}	-	7	9	V
		-	10.5	13	
Forward clamping voltage (negative transients) $I_{\text{PP}} = 1 \text{ A}, t_p = 8/20 \mu\text{s}^2)$ $I_{\text{PP}} = 10 \text{ A}, t_p = 8/20 \mu\text{s}^2)$	V_{FC}	-	1	3	
		-	3.5	6	
Diode capacitance $V_{\text{R}} = 0 \text{ V}, f = 1 \text{ MHz}$ $V_{\text{R}} = 5 \text{ V}, f = 1 \text{ MHz}$	C_{T}	-	70	90	pF
		-	35	55	

¹⁾ V_{ESD} according to IEC61000-4-2

²⁾ I_{pp} according to IEC61000-4-5

Power derating curve $P_{pk} = f(T_A)$

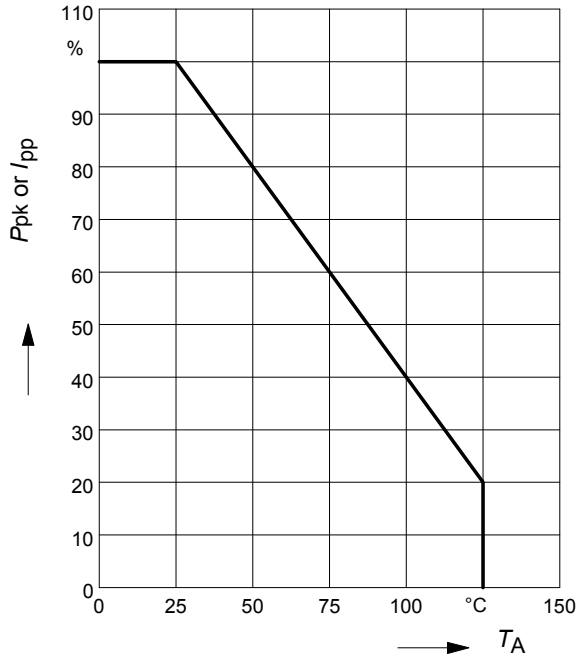

Clamping voltage, $V_{cl} = f(I_{pp})$

$t_p = 8 / 20 \mu s$ (positive transients)

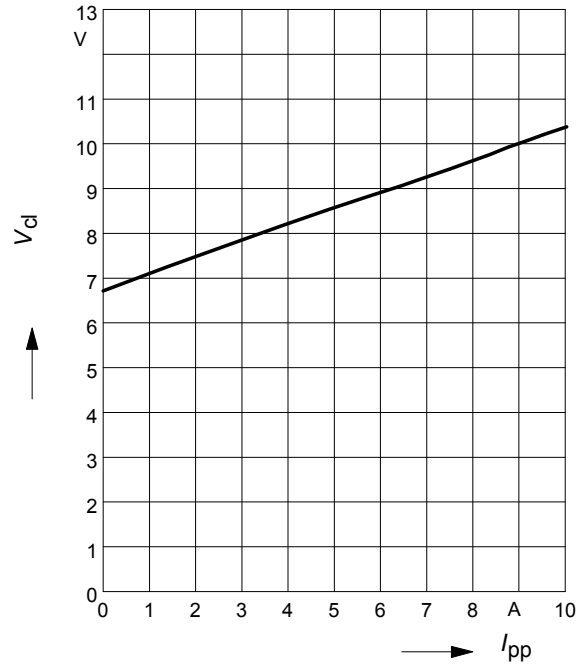

Forward clamping voltage $V_{FC} = f(I_{pp})$

$t_p = 8 / 20 \mu s$ (negative transients)

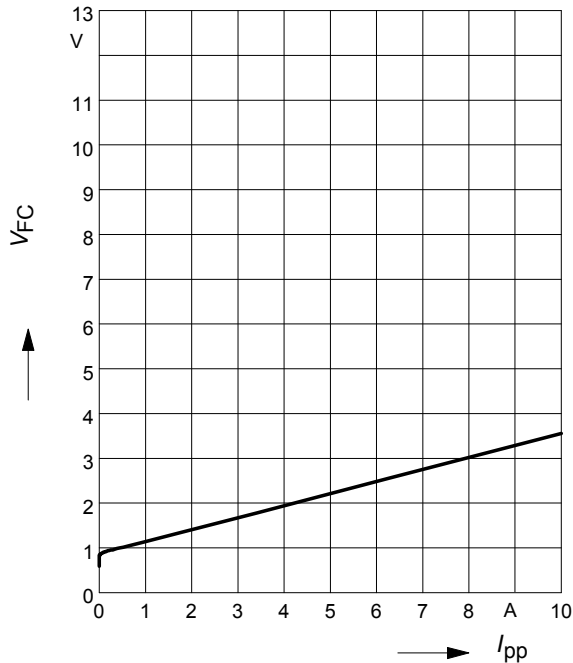

Reverse current $I_R = f(V_R)$

$T_A = \text{Parameter}$

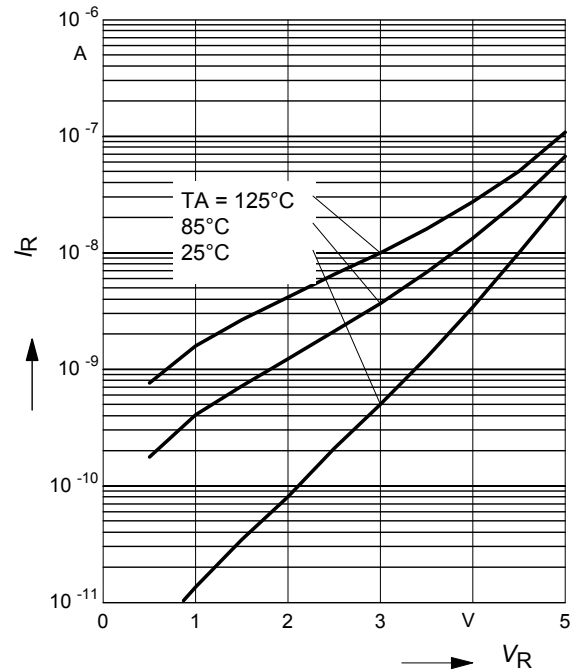

Normalized reverse voltage

$$V_{BR}(T_A)/V_{BR}(25^\circ\text{C}) = f(T_A)$$

$I_R = 1 \text{ mA}$

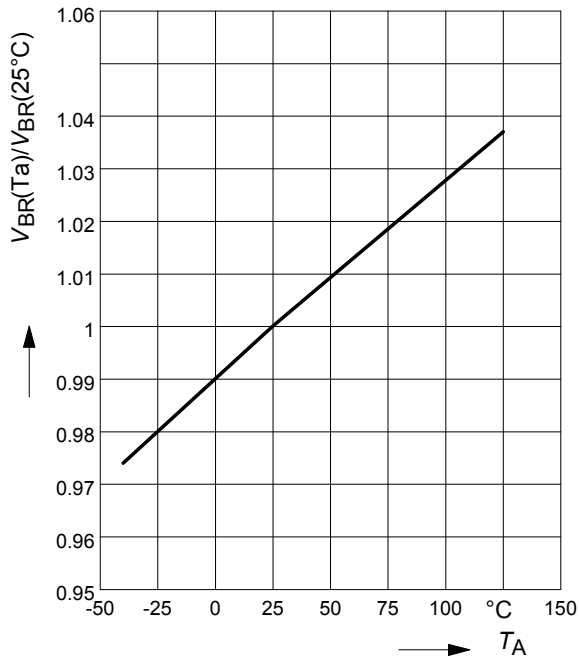

Diode capacitance $C_T = f(V_R)$

$f = 1 \text{ MHz}$

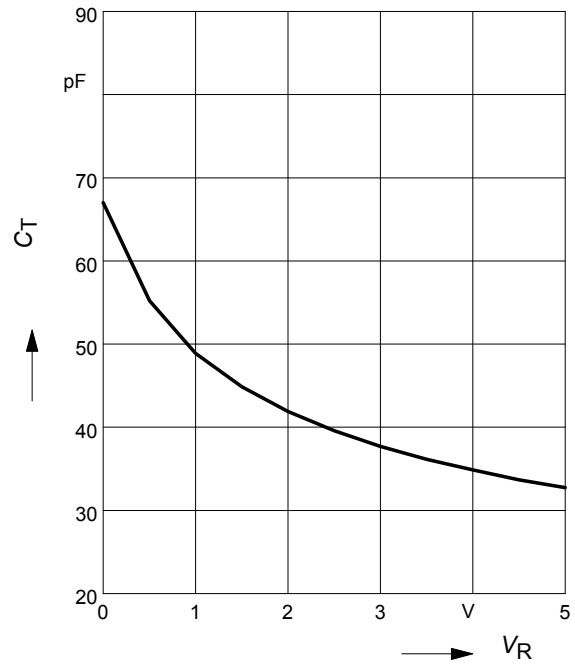

Application example ESD5V0S5US
5 channels, uni-directional

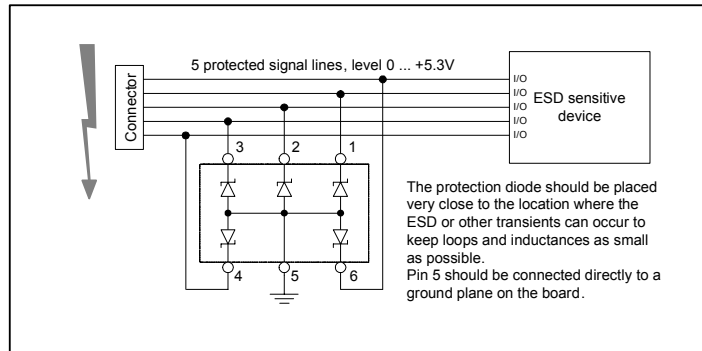

Application example ESD5V0S5US
4 channels, bi-directional

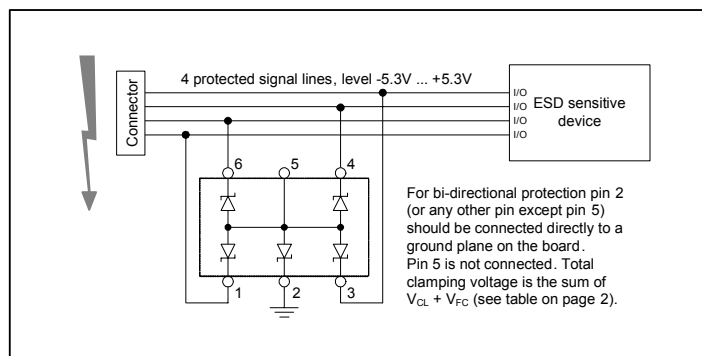

Application example ESD5V0S4US
4 channels, uni-directional

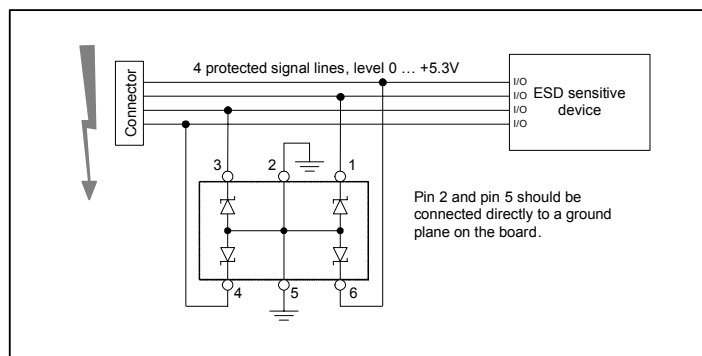

Package Outline

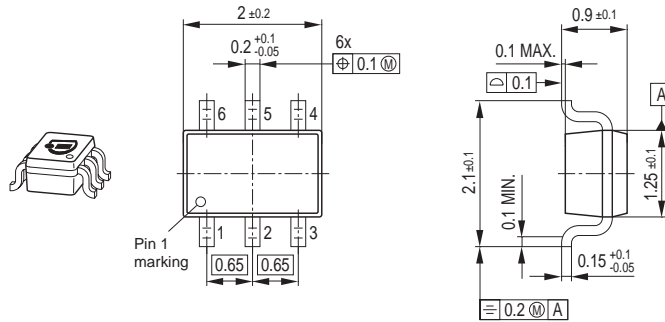

Foot Print

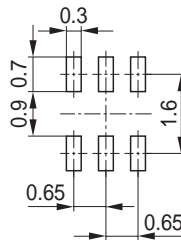

Marking Layout (Example)

Small variations in positioning of Date code, Type code and Manufacture are possible.

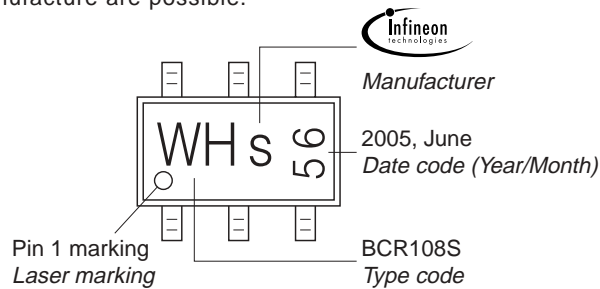

Standard Packing

Reel \varnothing 180 mm = 3.000 Pieces/Reel
 Reel \varnothing 330 mm = 10.000 Pieces/Reel

For symmetric types no defined Pin 1 orientation in reel.

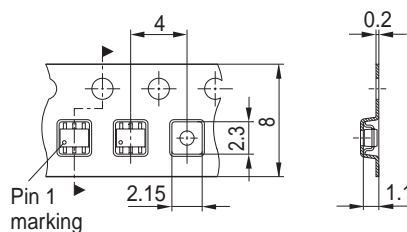

Edition 2006-02-01

Published by

Infineon Technologies AG

81726 München, Germany

© Infineon Technologies AG 2007.

All Rights Reserved.

Attention please!

The information given in this document shall in no event be regarded as a guarantee of conditions or characteristics ("Beschaffenheitsgarantie"). With respect to any examples or hints given herein, any typical values stated herein and/or any information regarding the application of the device, Infineon Technologies hereby disclaims any and all warranties and liabilities of any kind, including without limitation warranties of non-infringement of intellectual property rights of any third party.

Information

For further information on technology, delivery terms and conditions and prices please contact your nearest Infineon Technologies Office (www.infineon.com).

Warnings

Due to technical requirements components may contain dangerous substances. For information on the types in question please contact your nearest Infineon Technologies Office.

Infineon Technologies Components may only be used in life-support devices or systems with the express written approval of Infineon Technologies, if a failure of such components can reasonably be expected to cause the failure of that life-support device or system, or to affect the safety or effectiveness of that device or system.

Life support devices or systems are intended to be implanted in the human body, or to support and/or maintain and sustain and/or protect human life. If they fail, it is reasonable to assume that the health of the user or other persons may be endangered.