

#### PROTECTION PRODUCTS - RailClamp®

##### Description

A RailClamp® is a low capacitance TVS array designed to protect high speed data interfaces. This series has been specifically designed to protect sensitive components which are connected to data and transmission lines from overvoltage caused by **ESD** (electrostatic discharge), **CDE** (Cable Discharge Events), and **Lightning**.

The unique design incorporates surge rated, low capacitance steering diodes and a TVS diode in a single package. During transient conditions, the steering diodes direct the transient current away from the protected IC. The internal TVS diode clamps the transient voltage to a safe level. The low capacitance array configuration allows the user to protect up to two high-speed data lines.

The RClamp®2502L is constructed using Semtech's proprietary EPD process technology. The EPD process provides low stand-off voltages with significant reductions in leakage current and capacitance over silicon-avalanche diode processes. They feature a true operating voltage of 2.5 volts for superior protection.

The RClamp2502L is in a 8-pin SOIC package. The leads are finished with lead-free matte tin. The combination of low clamping voltage, high surge capability, and low loading capacitance makes the RClamp2502L an ideal solution for protecting GbE systems to the lightning immunity requirements of GR-1089.

##### Features

- ◆ Transient protection for high-speed data lines to **IEC 61000-4-2 (ESD) ±15kV (air), ±8kV (contact)**  
**IEC 61000-4-4 (EFT) 40A (5/50ns)**  
**IEC 61000-4-5 (Lightning) 24A (1.2/50µs)**
- ◆ Array of surge rated diodes with internal TVS Diode
- ◆ Protects up to two I/O lines
- ◆ Low capacitance: **<5pF (Line-to-Line)**
- ◆ High surge capability: **40A (tp=8/20µs)**
- ◆ Low operating voltage: **2.5V**
- ◆ Easy layout
- ◆ Solid-state silicon-avalanche technology

##### Mechanical Characteristics

- ◆ JEDEC SO-8 package
- ◆ Pb-Free, Halogen Free, RoHS/WEEE Compliant
- ◆ Lead Finish: Matte tin
- ◆ Molding compound flammability rating: UL 94V-0
- ◆ Marking : Marking Code, date code
- ◆ Packaging : Tape and Reel

##### Applications

- ◆ 10/100/1000 Ethernet Interfaces
- ◆ CPE Equipment
- ◆ GPON Systems
- ◆ VoIP Phones
- ◆ Video Surveillance Systems

##### Functional Circuit Diagram

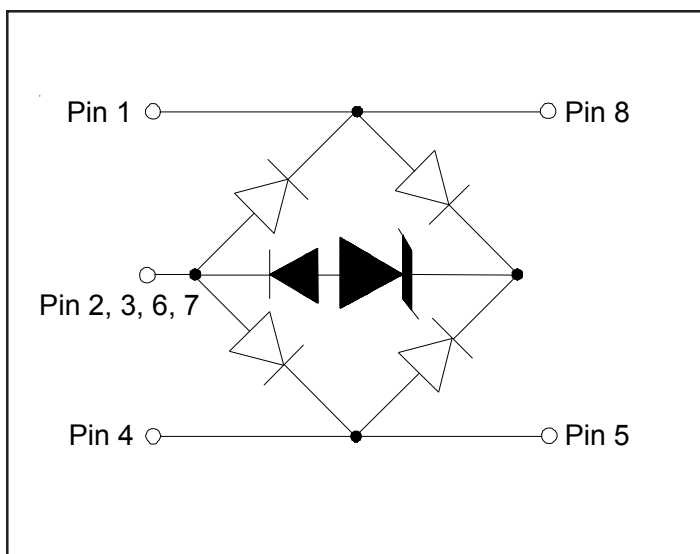

##### Package Configuration

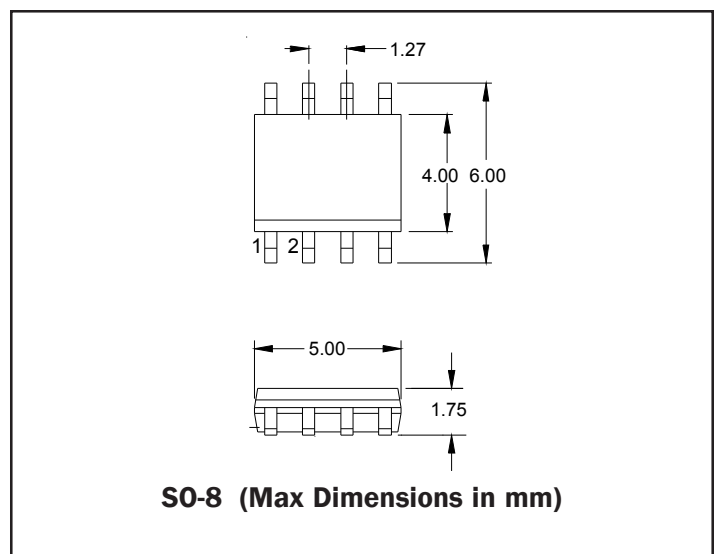

## PROTECTION PRODUCTS

### Absolute Maximum Rating

| Rating   | Symbol    | Value       | Units |
|--|-----------|-------------|-------|
| Peak Pulse Power (tp = 8/20μs)                                 | $P_{pk}$  | 800         | Watts |
| Peak Pulse Current (tp = 8/20μs)                               | $I_{pp}$  | 40          | A     |
| ESD per IEC 61000-4-2 (Air)<br>ESD per IEC 61000-4-2 (Contact) | $V_{ESD}$ | 25<br>15    | kV    |
| Operating Temperature  | $T_J$     | -40 to +85  | °C    |
| Storage Temperature  | $T_{STG}$ | -55 to +150 | °C    |

### Electrical Characteristics (T=25°C)

| RClamp2502L               |           |  |         |         |         |       |
|---------------------------|-----------|--|---------|---------|---------|-------|
| Parameter                 | Symbol    | Conditions   | Minimum | Typical | Maximum | Units |
| Reverse Stand-Off Voltage | $V_{RWM}$ |  |         |         | 2.5     | V     |
| Punch-Through Voltage     | $V_{PT}$  | $I_{PT} = 2\mu A$  | 2.7     |         |         | V     |
| Snap-Back Voltage         | $V_{SB}$  | $I_{SB} = 50mA$  | 2.8     |         |         | V     |
| Reverse Leakage Current   | $I_R$     | $V_{RWM} = 2.5V, T=25^\circ C$                               |         |         | 1       | μA    |
| Clamping Voltage          | $V_C$     | $I_{pp} = 12A, t_p = 8/20\mu s$<br>Between pins 1, 8 and 4,5 |         |         | 9.5     | V     |
| Clamping Voltage          | $V_C$     | $I_{pp} = 24A, t_p = 8/20\mu s$<br>Between pins 1, 8 and 4,5 |         |         | 12.5    | V     |
| Clamping Voltage          | $V_C$     | $I_{pp} = 40A, t_p = 8/20\mu s$<br>Between pins 1, 8 and 4,5 |         |         | 20      | V     |
| Junction Capacitance      | $C_j$     | Between pins 1,8 or 4,5 and 2,3<br>$V_R = 0V, f = 1MHz$      |         |         | 10      | pF    |
|                           |           | Between pins 1, 8 and 4,5<br>$V_R = 0V, f = 1MHz$            |         |         | 5       | pF    |

## PROTECTION PRODUCTS

### Typical Characteristics

#### Non-Repetitive Peak Pulse Power vs. Pulse Time

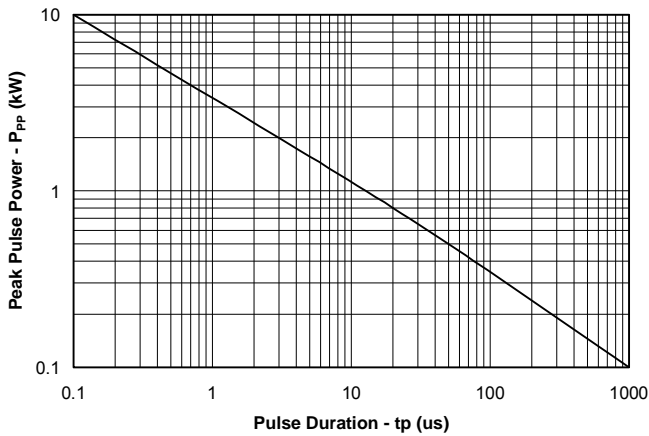

#### Power Derating Curve

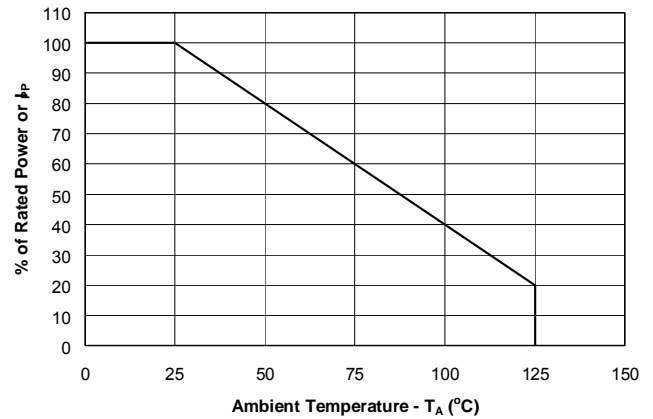

#### Pulse Waveform

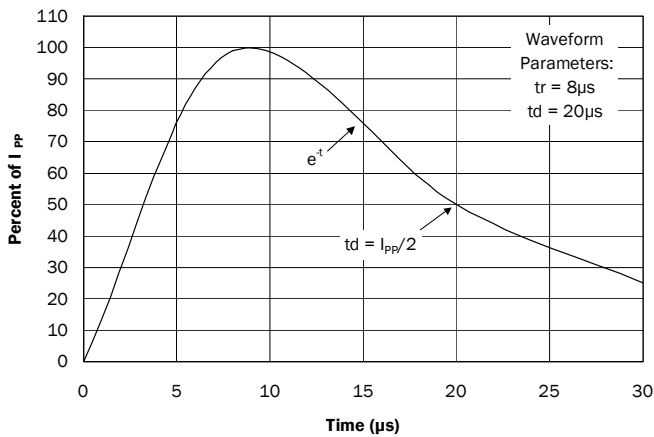

#### Normalized Junction Capacitance vs. Reverse Voltage (I/O to I/O)

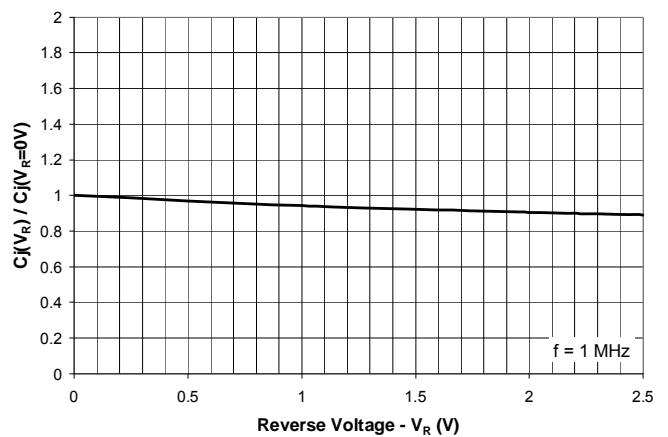

#### Clamping Voltage vs. Peak Pulse Current (I/O to I/O)

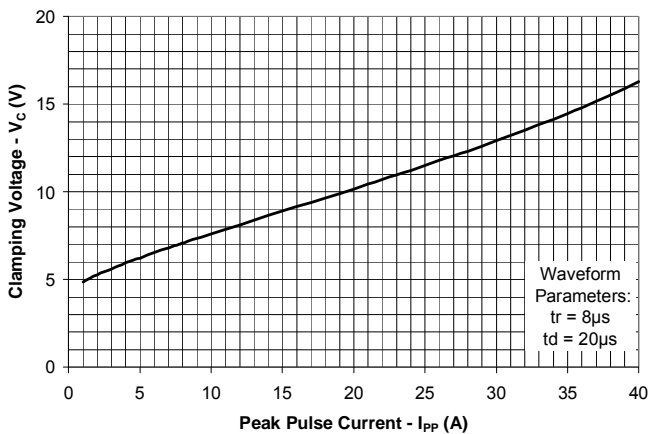

#### ESD Clamping (8kV Contact per IEC 61000-4-2)

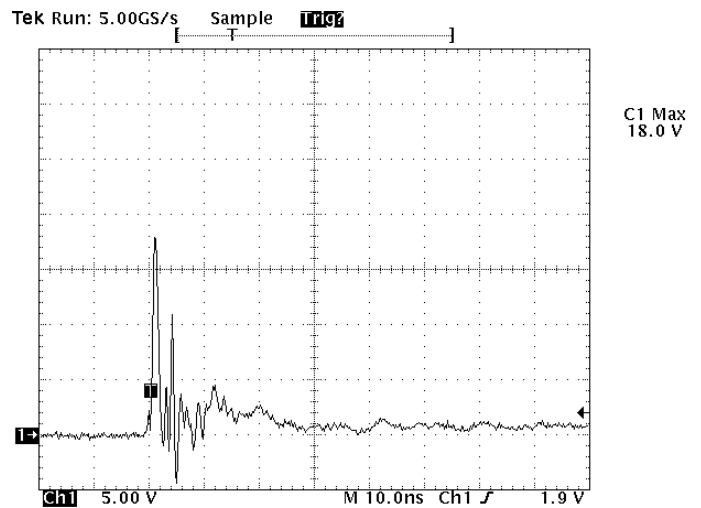

Note: Data is taken with a 10x attenuator

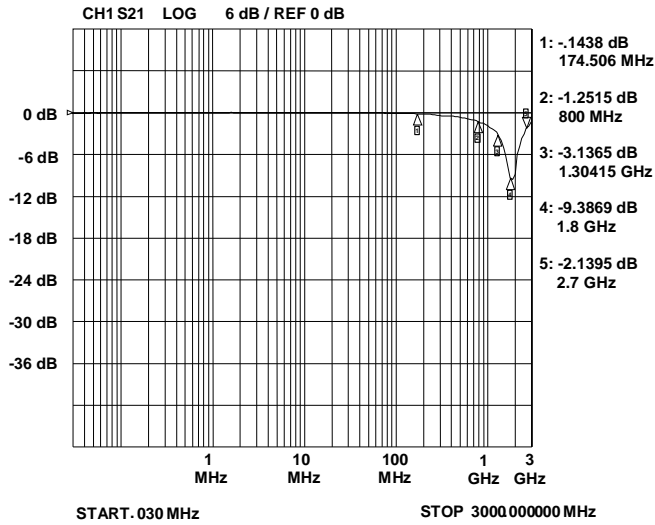
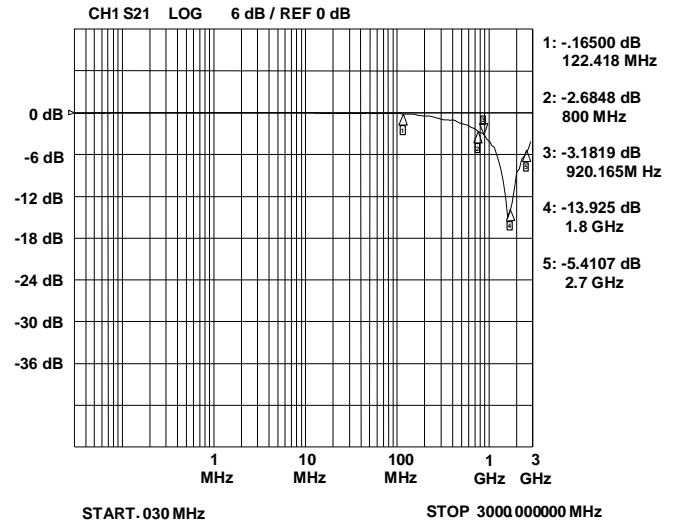
**PROTECTION PRODUCTS**
**Typical Characteristics**
**Insertion Loss S21 (I/O to I/O)**

**Insertion Loss S21 (I/O to Ground)**

## PROTECTION PRODUCTS

### Applications Information

#### Device Connection Options for Protection of Two High-Speed Data Lines

The RClamp2502L is designed to protect two high-speed data lines (one differential pair) from transient over-voltages which result from lightning and ESD. Data line inputs/outputs are connected at pins 1 to 8, and 4 to 5. The device is designed such that PCB traces can remain unbroken and routed thru the device as shown. Differential protection is achieved by leaving pins 2, 3, 6, and 7 not connected.

#### Protecting Ethernet-based Systems to the Short-Haul/Intrabuilding Lightning Immunity Requirements of GR-1089

The Telcordia Technologies (Bellcore) GR-1089-CORE specification defines a set of requirements for lightning and AC power cross immunity for intrabuilding equipment. The lightning tests are applied as  $\pm 800$  volt metallic (line-to-line) or  $\pm 1500$  volt longitudinal (line-to-ground) surges. The waveforms are defined with a rise time of  $2\mu\text{s}$  and a decay time of  $10\mu\text{s}$  with a short circuit current of 100A. One surge of positive and one of negative polarity are applied. To pass the test, the equipment must continue to operate after the test. The combination of low clamping voltage, high surge capability, and low loading capacitance makes the RClamp2502L an ideal solution for protecting GbE systems to the lightning immunity requirements of GR-1089. In a typical system the RClamp2502L is located on the PHY side of the transformer (see schematic on next page). One device is required for each transmit and receive line pair. This configuration relies on the transformer isolation voltage to suppress the 1500 volt common mode surge. While this negates the need for longitudinal line side protection, it is important to make sure the resistor/capacitor termination networks are rated accordingly. During metallic mode surges, energy will be transferred through the magnetics until the transformer saturates. The RClamp2502L will clamp the transferred voltage to a safe level, protecting the Ethernet PHY. The amount of energy will vary depending on the transformer, but will be well within the surge handling capability of the RClamp2502L. As always, the final design should be verified with testing.

**Circuit Diagram**

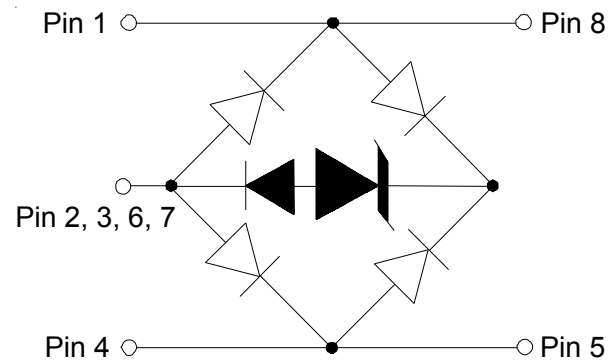

**Connection for Differential Protection (Line-to-Line)**

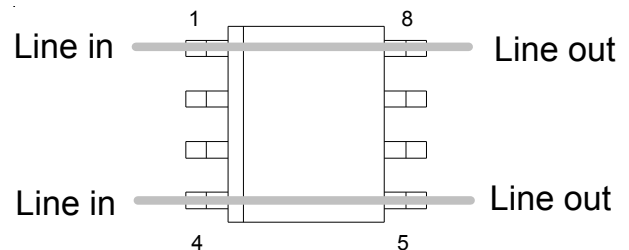

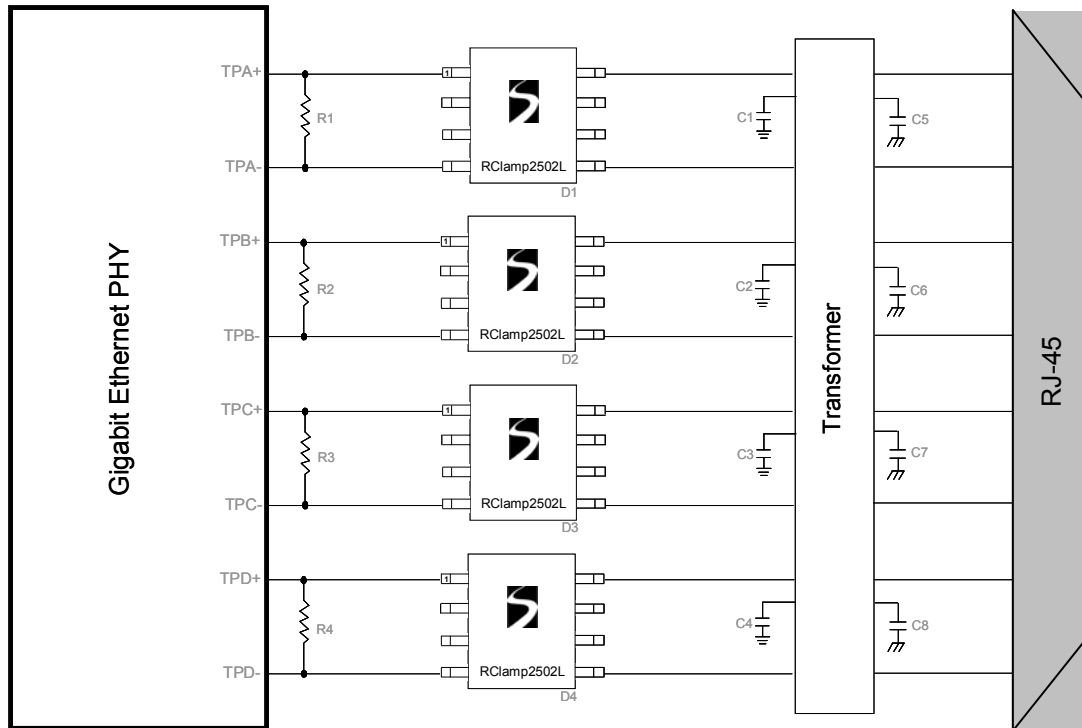

**Schematic Diagram for Gigabit Ethernet Telcordia GR-1089 Intra-Building Protection (PHY Operating Temp  $\leq 90^{\circ}\text{C}$  with 100m of CAT 5)**

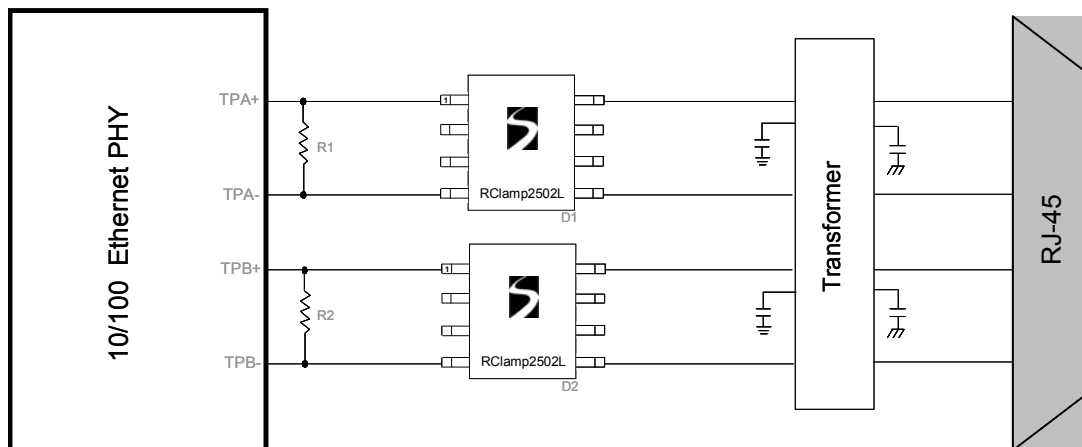

**Schematic Diagram for 10/100 Ethernet Telcordia GR-1089 Intra-Building Protection**

## PROTECTION PRODUCTS

### Applications Information - Spice Model

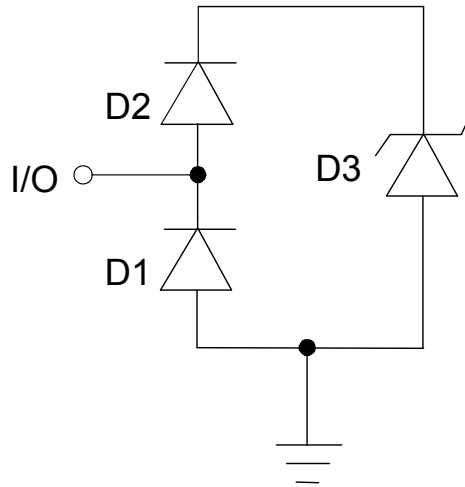

**RClamp2502L Spice Model**

| RClamp2502L Spice Parameters |       |          |          |          |
|------------------------------|-------|----------|----------|----------|
| Parameter                    | Unit  | D1       | D2       | D3       |
| IS                           | Amp   | 1E-14    | 1E-14    | 1.66E-13 |
| BV                           | Volt  | 100      | 100      | 2.89     |
| VJ                           | Volt  | 0.6      | 0.6      | 0.53     |
| RS                           | Ohm   | 0.09     | 0.15     | 0.06     |
| IBV                          | Amp   | 1E-3     | 1E-3     | 1E-3     |
| CJO                          | Farad | 2E-12    | 2E-12    | 288E-12  |
| TT                           | sec   | 2.541E-9 | 2.541E-9 | 2.541E-9 |
| M                            | --    | 0.01     | 0.01     | 0.17     |
| N                            | --    | 1.1      | 1.1      | 1.1      |
| EG                           | eV    | 1.11     | 1.11     | 1.11     |

## PROTECTION PRODUCTS

### Outline Drawing - SOIC-8

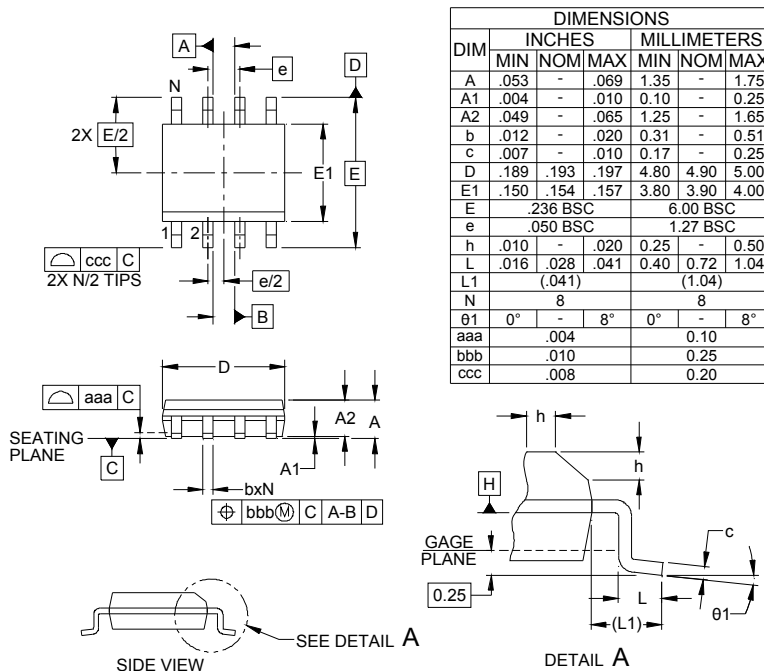

**NOTES:**

1. CONTROLLING DIMENSIONS ARE IN MILLIMETERS (ANGLES IN DEGREES).
2. DATUMS [-A-] AND [-B-] TO BE DETERMINED AT DATUM PLANE [-H-].
3. DIMENSIONS "E1" AND "D" DO NOT INCLUDE MOLD FLASH, PROTRUSIONS OR GATE BURRS.
4. REFERENCE JEDEC STD MS-012, VARIATION AA.

### Land Pattern - SOIC-8

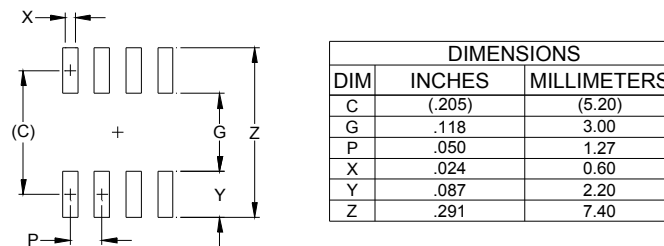

**NOTES:**

1. THIS LAND PATTERN IS FOR REFERENCE PURPOSES ONLY. CONSULT YOUR MANUFACTURING GROUP TO ENSURE YOUR COMPANY'S MANUFACTURING GUIDELINES ARE MET.
2. REFERENCE IPC-SM-782A, RLP NO. 300A.



## PROTECTION PRODUCTS

### Marking

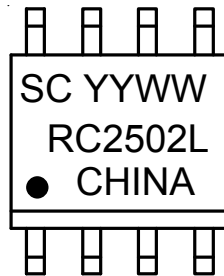

YYWW = Date Code

### Ordering Information

| Part Number     | Working Voltage | Qty per Reel | Reel Size |
|-----------------|-----------------|--------------|-----------|
| RClamp2502L.TBT | 2.5 Volts       | 500          | 7 Inch    |

RailClamp and RClamp are marks of Semtech Corporation

### Tape and Reel Specification

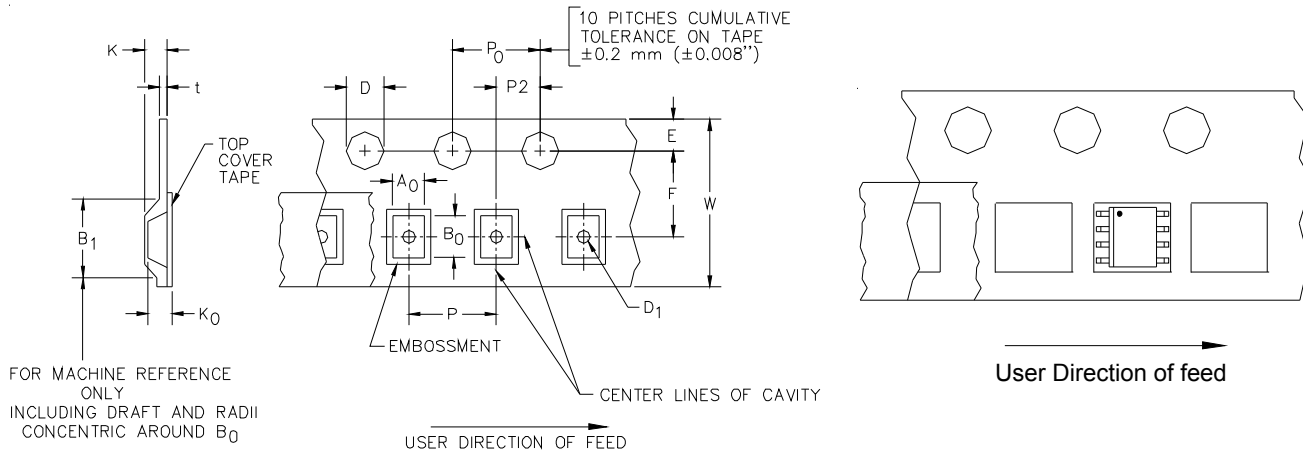

### Device Orientation in Tape

| A0              | B0              | K0              |
|-----------------|-----------------|-----------------|
| 6.50 +/-0.20 mm | 5.40 +/-0.20 mm | 2.00 +/-0.10 mm |

| Tape Width | B, (Max)      | D                     | D1     | E            | F           | K (MAX) | P          | P0         | P2          | T(MAX) | W              |
|------------|---------------|-----------------------|--------|--------------|-------------|---------|------------|------------|-------------|--------|----------------|
| 12 mm      | 8.2 mm (.476) | 1.5 + 0.1 mm - 0.0 mm | 1.5 mm | 1.750±.10 mm | 5.5±0.05 mm | 4.5 mm  | 4.0±0.1 mm | 4.0±0.1 mm | 2.0±0.05 mm | 0.4 mm | 12 mm ± 0.3 mm |

### Contact Information

Semtech Corporation  
 Protection Products Division  
 200 Flynn Rd., Camarillo, CA 93012  
 Phone: (805)498-2111 FAX (805)498-3804