

PESDxS2UQ series

Double ESD protection diodes in SOT663 package

Rev. 03 — 11 September 2008

Product data sheet

IMPORTANT NOTICE

Dear customer,

As from October 1st, 2006 Philips Semiconductors has a new trade name - NXP Semiconductors, which will be used in future data sheets together with new contact details.

In data sheets where the previous Philips references remain, please use the new links as shown below.

<http://www.philips.semiconductors.com> use <http://www.nxp.com>

<http://www.semiconductors.philips.com> use <http://www.nxp.com> (Internet)

sales.addresses@www.semiconductors.philips.com use salesaddresses@nxp.com (email)

The copyright notice at the bottom of each page (or elsewhere in the document, depending on the version)

- © Koninklijke Philips Electronics N.V. (year). All rights reserved -

is replaced with:

- © NXP B.V. (year). All rights reserved. -

If you have any questions related to the data sheet, please contact our nearest sales office via e-mail or phone (details via salesaddresses@nxp.com). Thank you for your cooperation and understanding,

NXP Semiconductors

Double ESD protection diodes in SOT663 package

PESDxS2UQ series

FEATURES

- Uni-directional ESD protection of up to two lines
- Max. peak pulse power: $P_{pp} = 150 \text{ W}$ at $t_p = 8/20 \mu\text{s}$
- Low clamping voltage: $V_{(CL)R} = 20 \text{ V}$ at $I_{pp} = 15 \text{ A}$
- Low reverse leakage current: $I_{RM} < 1 \text{ nA}$
- ESD protection $> 30 \text{ kV}$
- IEC 61000-4-2; level 4 (ESD)
- IEC 61000-4-5 (surge); $I_{pp} = 15 \text{ A}$ at $t_p = 8/20 \mu\text{s}$.

APPLICATIONS

- Computers and peripherals
- Communication systems
- Audio and video equipment
- High speed data lines
- Parallel ports.

DESCRIPTION

Uni-directional double ESD protection diodes in a SOT663 plastic package. Designed to protect up to two transmission or data lines from ElectroStatic Discharge (ESD) damage.

MARKING

TYPE NUMBER	MARKING CODE
PESD3V3S2UQ	E1
PESD5V0S2UQ	E2
PESD12VS2UQ	E3
PESD15VS2UQ	E4
PESD24VS2UQ	E5

QUICK REFERENCE DATA

SYMBOL	PARAMETER	VALUE	UNIT
V_{RWM}	reverse stand-off voltage	3.3, 5, 12, 15 and 24	V
C_d	diode capacitance $V_R = 0 \text{ V};$ $f = 1 \text{ MHz}$	200, 150, 38, 32 and 23	pF
	number of protected lines	2	

PINNING

PIN	DESCRIPTION
1	cathode 1
2	cathode 2
3	common anode

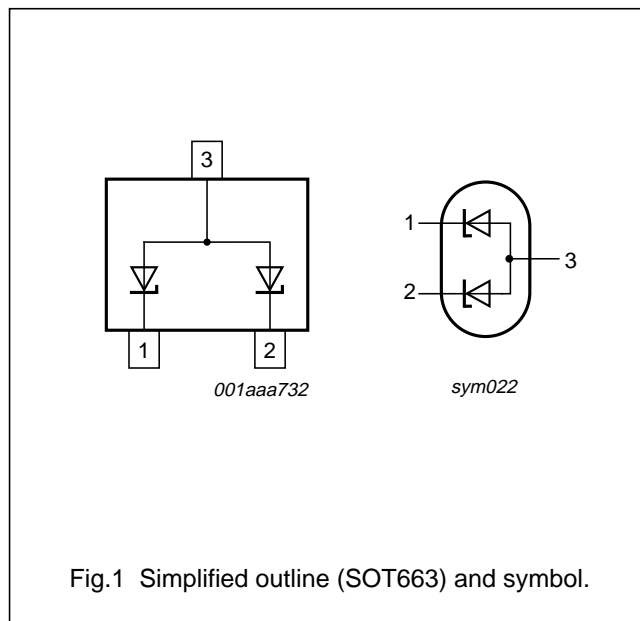

Double ESD protection diodes in SOT663 package

PESDxS2UQ series

ORDERING INFORMATION

TYPE NUMBER	PACKAGE		
	NAME	DESCRIPTION	VERSION
PESD3V3S2UQ	-	plastic surface mounted package; 3 leads	SOT663
PESD5V0S2UQ			
PESD12VS2UQ			
PESD15VS2UQ			
PESD24VS2UQ			

LIMITING VALUES

In accordance with the Absolute Maximum Rating System (IEC 60134).

SYMBOL	PARAMETER	CONDITIONS	MIN.	MAX.	UNIT			
P_{pp}	peak pulse power	8/20 μ s pulse; notes 1 and 2	-	150	W			
I_{pp}	peak pulse current	8/20 μ s pulse; notes 1 and 2						
	PESD3V3S2UQ					-	15	A
	PESD5V0S2UQ					-	15	A
	PESD12VS2UQ					-	5	A
	PESD15VS2UQ					-	5	A
	PESD24VS2UQ	-	3	A				
T_j	junction temperature		-	150	$^{\circ}$ C			
T_{amb}	operating ambient temperature		-65	+150	$^{\circ}$ C			
T_{stg}	storage temperature		-65	+150	$^{\circ}$ C			

Notes

1. Non-repetitive current pulse 8/20 μ s exponential decaying waveform; see Fig.2.
2. Measured across either pins 1 and 3 or pins 2 and 3.

Double ESD protection diodes in SOT663 package

PESDxS2UQ series

ESD maximum ratings

SYMBOL	PARAMETER	CONDITIONS	VALUE	UNIT
ESD	electrostatic discharge capability	IEC 61000-4-2 (contact discharge); notes 1 and 2		
		PESD3V3S2UQ	30	kV
		PESD5V0S2UQ	30	kV
		PESD12VS2UQ	30	kV
		PESD15VS2UQ	30	kV
		PESD24VS2UQ	23	kV
	HBM MIL-Std 883 PESDxS2UQ series	10	kV	

Notes

1. Device stressed with ten non-repetitive ElectroStatic Discharge (ESD) pulses; see Fig.3.
2. Measured across either pins 1 and 3 or pins 2 and 3.

ESD standards compliance

ESD STANDARD	CONDITIONS
IEC 61000-4-2; level 4 (ESD); see Fig.3	>15 kV (air); > 8 kV (contact)
HBM MIL-Std 883; class 3	>4 kV

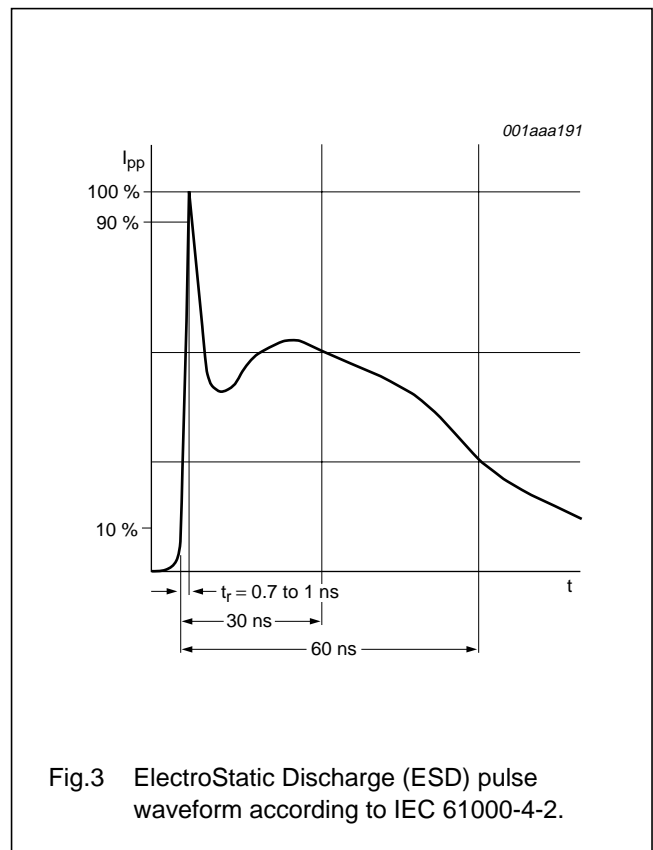
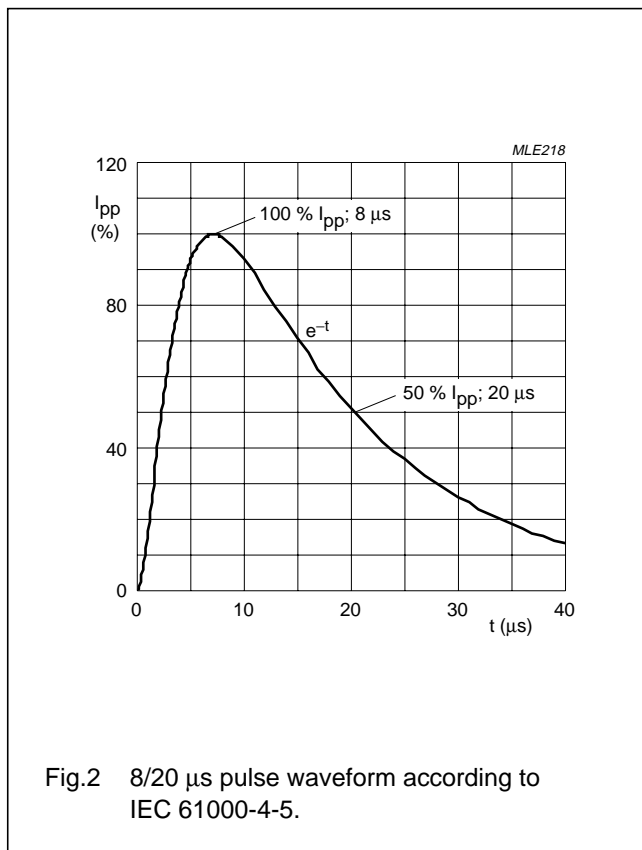

Double ESD protection diodes in SOT663 package

PESDxS2UQ series

ELECTRICAL CHARACTERISTICS

$T_j = 25\text{ °C}$ unless otherwise specified.

SYMBOL	PARAMETER	CONDITIONS	MIN.	TYP.	MAX.	UNIT
V_{RWM}	reverse stand-off voltage					
	PESD3V3S2UQ		–	–	3.3	V
	PESD5V0S2UQ		–	–	5	V
	PESD12VS2UQ		–	–	12	V
	PESD15VS2UQ		–	–	15	V
	PESD24VS2UQ		–	–	24	V
I_{RM}	reverse leakage current					
	PESD3V3S2UQ	$V_{RWM} = 3.3\text{ V}$	–	0.55	3	μA
	PESD5V0S2UQ	$V_{RWM} = 5\text{ V}$	–	50	300	nA
	PESD12VS2UQ	$V_{RWM} = 12\text{ V}$	–	<1	30	nA
	PESD15VS2UQ	$V_{RWM} = 15\text{ V}$	–	<1	50	nA
	PESD24VS2UQ	$V_{RWM} = 24\text{ V}$	–	<1	50	nA
V_{BR}	breakdown voltage	$I_Z = 5\text{ mA}$				
	PESD3V3S2UQ		5.2	5.6	6.0	V
	PESD5V0S2UQ		6.4	6.8	7.2	V
	PESD12VS2UQ		14.7	15.0	15.3	V
	PESD15VS2UQ		17.6	18.0	18.4	V
	PESD24VS2UQ		26.5	27.0	27.5	V
C_d	diode capacitance	$f = 1\text{ MHz}; V_R = 0\text{ V}$				
	PESD3V3S2UQ		–	200	275	pF
	PESD5V0S2UQ		–	150	215	pF
	PESD12VS2UQ		–	38	100	pF
	PESD15VS2UQ		–	32	70	pF
	PESD24VS2UQ		–	23	50	pF
$V_{(CL)R}$	clamping voltage	notes 1 and 2				
	PESD3V3S2UQ	$I_{pp} = 1\text{ A}$	–	–	8	V
		$I_{pp} = 15\text{ A}$	–	–	20	V
	PESD5V0S2UQ	$I_{pp} = 1\text{ A}$	–	–	9	V
		$I_{pp} = 15\text{ A}$	–	–	20	V
	PESD12VS2UQ	$I_{pp} = 1\text{ A}$	–	–	19	V
		$I_{pp} = 5\text{ A}$	–	–	35	V
	PESD15VS2UQ	$I_{pp} = 1\text{ A}$	–	–	23	V
		$I_{pp} = 5\text{ A}$	–	–	40	V
	PESD24VS2UQ	$I_{pp} = 1\text{ A}$	–	–	36	V
$I_{pp} = 3\text{ A}$		–	–	70	V	

Double ESD protection diodes in SOT663 package

PESDxS2UQ series

SYMBOL	PARAMETER	CONDITIONS	MIN.	TYP.	MAX.	UNIT
R_{diff}	differential resistance					
	PESD3V3S2UQ	$I_R = 5 \text{ mA}$	–	–	40	Ω
	PESD5V0S2UQ	$I_R = 5 \text{ mA}$	–	–	15	Ω
	PESD12VS2UQ	$I_R = 5 \text{ mA}$	–	–	15	Ω
	PESD15VS2UQ	$I_R = 1 \text{ mA}$	–	–	225	Ω
	PESD24VS2UQ	$I_R = 0.5 \text{ mA}$	–	–	300	Ω

Notes

1. Non-repetitive current pulse 8/20 μs exponential decay waveform; see Fig.2.
2. Measured either across pins 1 and 3 or pins 2 and 3.

GRAPHICAL DATA

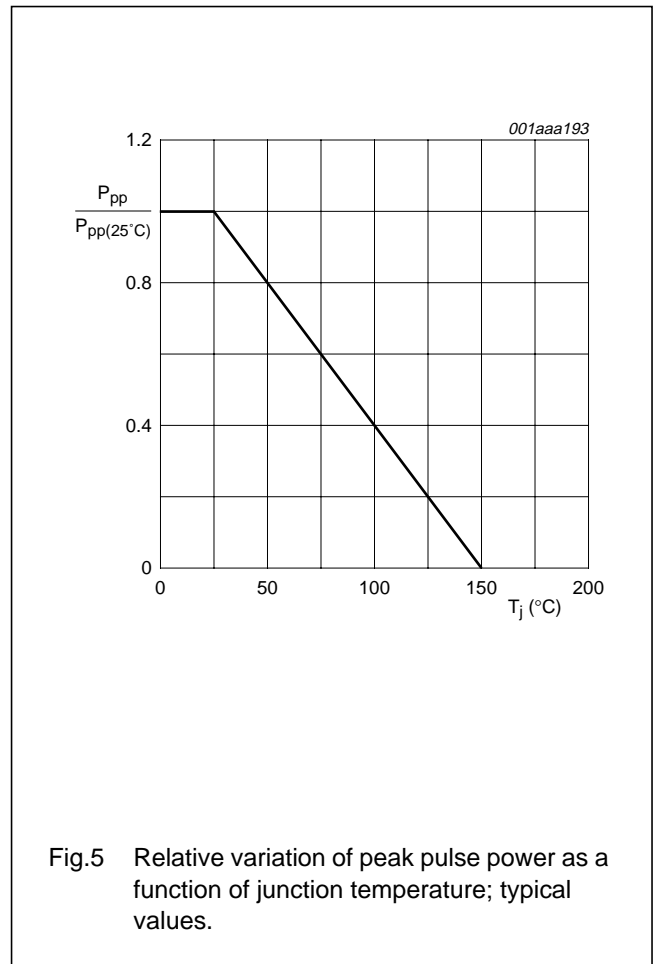
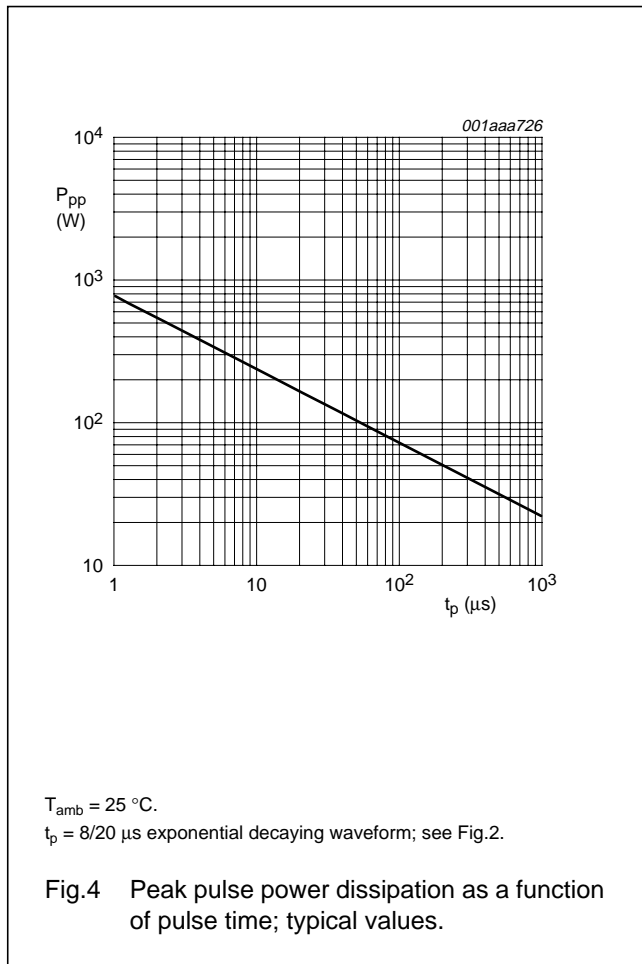

Double ESD protection diodes
in SOT663 package

PESDxS2UQ series

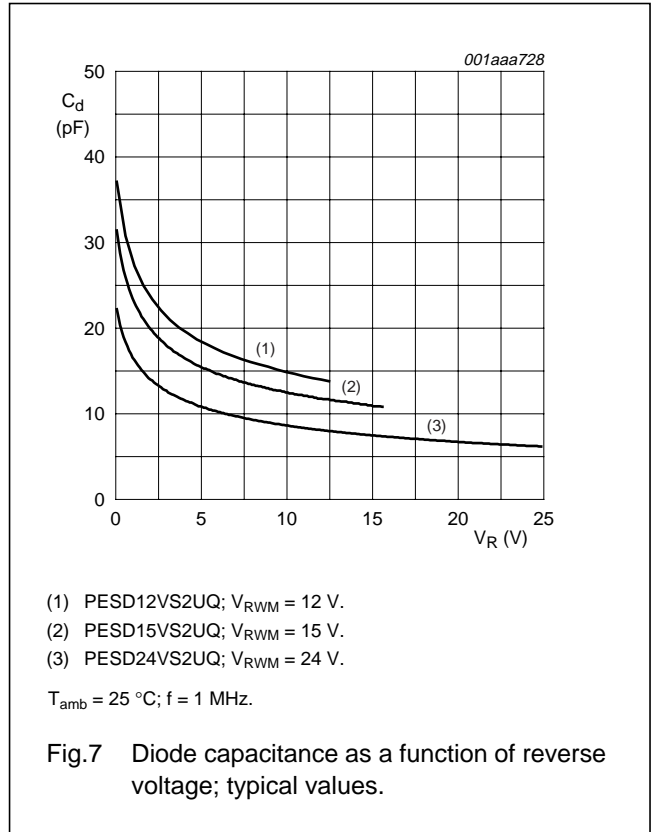
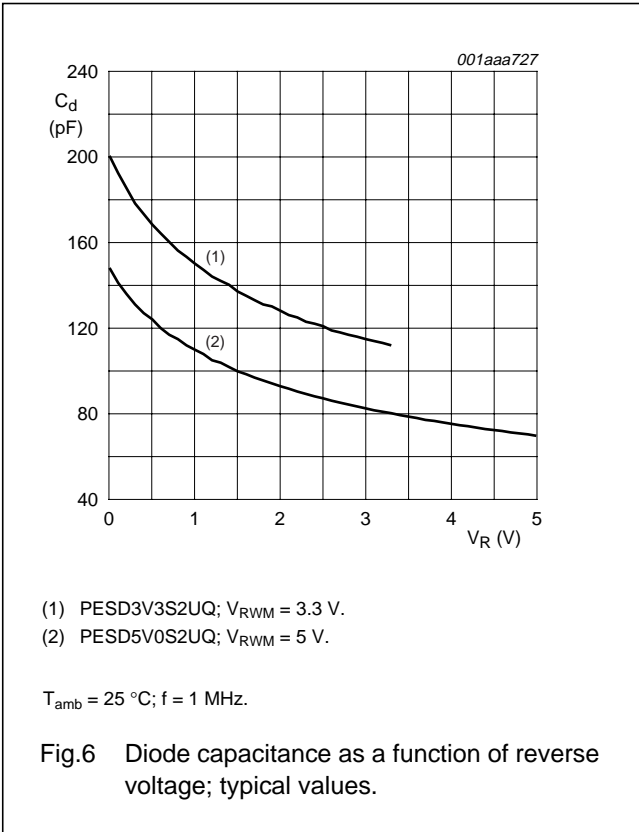

Double ESD protection diodes
in SOT663 package

PESDxS2UQ series

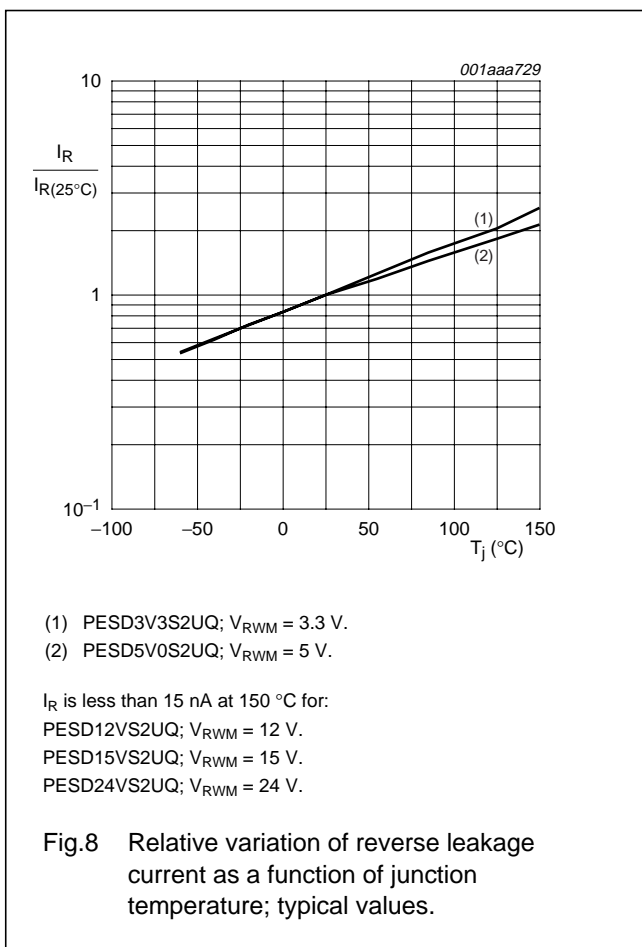

Double ESD protection diodes in SOT663 package

PESDxS2UQ series

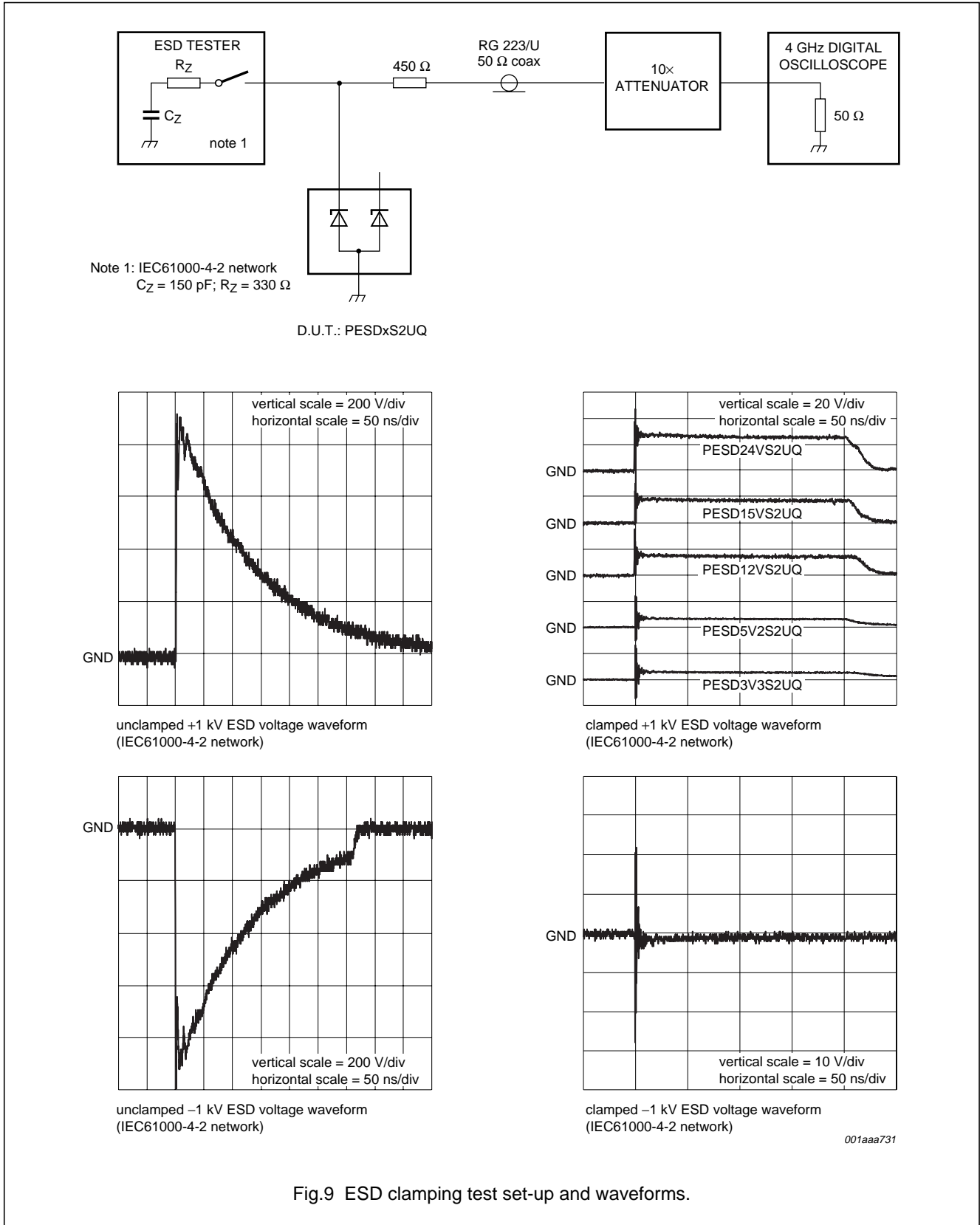

Fig.9 ESD clamping test set-up and waveforms.

Double ESD protection diodes in SOT663 package

PESDxS2UQ series

APPLICATION INFORMATION

The PESDxS2UQ series is designed for uni-directional protection for up to two data lines against damage caused by ElectroStatic Discharge (ESD) and surge pulses. The PESDxS2UQ series may be used on lines where the signal polarities are below ground. PESDxS2UQ series provide a surge capability of up to 150 W (P_{pp}) per line for an 8/20 μ s waveform.

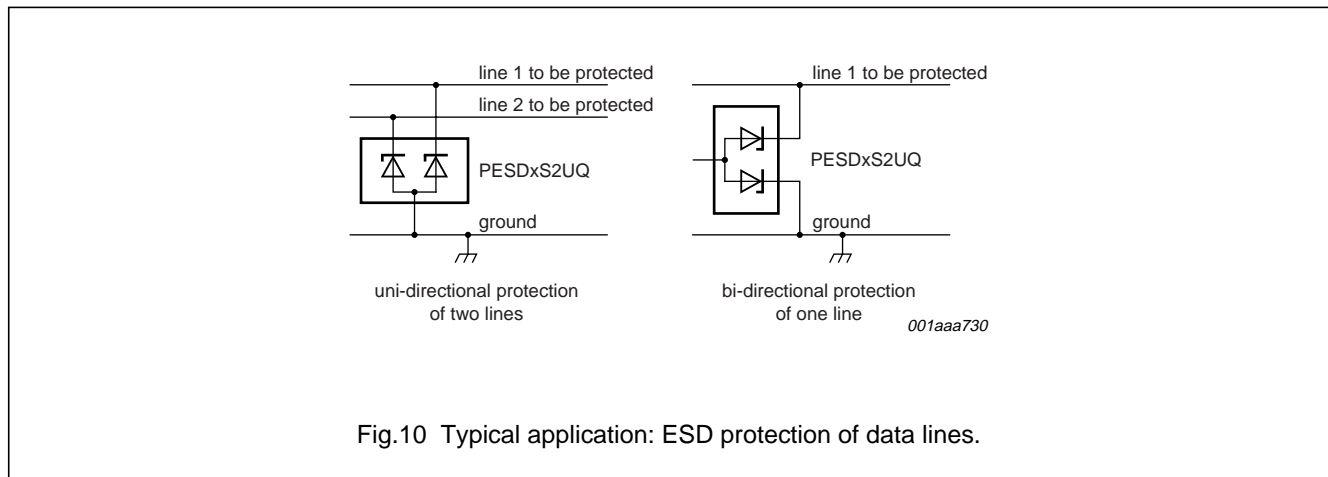

Circuit board layout and protection device placement

Circuit board layout is critical for the suppression of ESD, Electrical Fast Transient (EFT) and surge transients. The following guidelines are recommended:

- Place the PESDxS2UQ as close as possible to the input terminal or connector.
- The path length between the PESDxS2UQ and the protected line should be minimized.
- Keep parallel signal paths to a minimum.
- Avoid running protected conductors in parallel with unprotected conductors.
- Minimize all printed-circuit board conductive loops including power and ground loops.
- Minimize the length of transient return paths to ground.
- Avoid using shared return paths to a common ground point.
- Ground planes should be used whenever possible. For multilayer printed-circuit boards use ground vias.

Double ESD protection diodes
in SOT663 package

PESDxS2UQ series

PACKAGE OUTLINE

Plastic surface mounted package; 3 leads

SOT663

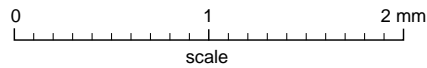
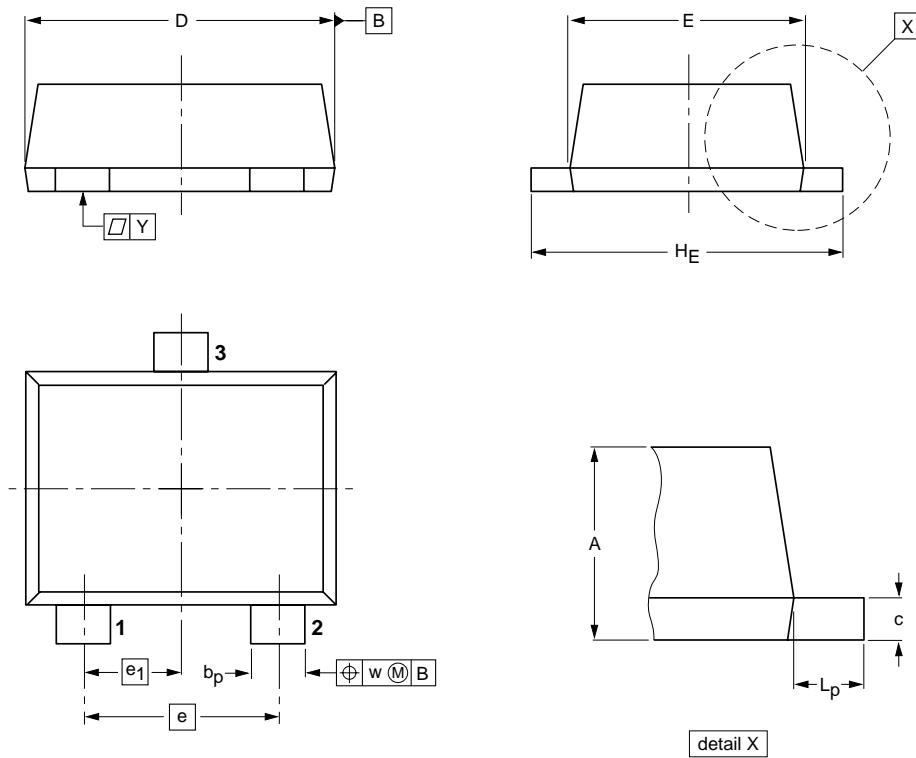

DIMENSIONS (mm are the original dimensions)

UNIT	A	b _p	c	D	E	e	e ₁	H _E	L _p	w	y
mm	0.6 0.5	0.33 0.23	0.18 0.08	1.7 1.5	1.3 1.1	1.0	0.5	1.7 1.5	0.3 0.1	0.1	0.1

OUTLINE VERSION	REFERENCES				EUROPEAN PROJECTION	ISSUE DATE
	IEC	JEDEC	JEITA			
SOT663						01-12-04 02-05-21

Legal information

Data sheet status

Document status ^{[1][2]}	Product status ^[3]	Definition
Objective [short] data sheet	Development	This document contains data from the objective specification for product development.
Preliminary [short] data sheet	Qualification	This document contains data from the preliminary specification.
Product [short] data sheet	Production	This document contains the product specification.

[1] Please consult the most recently issued document before initiating or completing a design.

[2] The term 'short data sheet' is explained in section "Definitions".

[3] The product status of device(s) described in this document may have changed since this document was published and may differ in case of multiple devices. The latest product status information is available on the Internet at URL <http://www.nxp.com>.

Definitions

Draft — The document is a draft version only. The content is still under internal review and subject to formal approval, which may result in modifications or additions. NXP Semiconductors does not give any representations or warranties as to the accuracy or completeness of information included herein and shall have no liability for the consequences of use of such information.

Short data sheet — A short data sheet is an extract from a full data sheet with the same product type number(s) and title. A short data sheet is intended for quick reference only and should not be relied upon to contain detailed and full information. For detailed and full information see the relevant full data sheet, which is available on request via the local NXP Semiconductors sales office. In case of any inconsistency or conflict with the short data sheet, the full data sheet shall prevail.

Disclaimers

General — Information in this document is believed to be accurate and reliable. However, NXP Semiconductors does not give any representations or warranties, expressed or implied, as to the accuracy or completeness of such information and shall have no liability for the consequences of use of such information.

Right to make changes — NXP Semiconductors reserves the right to make changes to information published in this document, including without limitation specifications and product descriptions, at any time and without notice. This document supersedes and replaces all information supplied prior to the publication hereof.

Suitability for use — NXP Semiconductors products are not designed, authorized or warranted to be suitable for use in medical, military, aircraft, space or life support equipment, nor in applications where failure or malfunction of an NXP Semiconductors product can reasonably be expected to result in personal injury, death or severe property or environmental

damage. NXP Semiconductors accepts no liability for inclusion and/or use of NXP Semiconductors products in such equipment or applications and therefore such inclusion and/or use is at the customer's own risk.

Applications — Applications that are described herein for any of these products are for illustrative purposes only. NXP Semiconductors makes no representation or warranty that such applications will be suitable for the specified use without further testing or modification.

Limiting values — Stress above one or more limiting values (as defined in the Absolute Maximum Ratings System of IEC 60134) may cause permanent damage to the device. Limiting values are stress ratings only and operation of the device at these or any other conditions above those given in the Characteristics sections of this document is not implied. Exposure to limiting values for extended periods may affect device reliability.

Terms and conditions of sale — NXP Semiconductors products are sold subject to the general terms and conditions of commercial sale, as published at <http://www.nxp.com/profile/terms>, including those pertaining to warranty, intellectual property rights infringement and limitation of liability, unless explicitly otherwise agreed to in writing by NXP Semiconductors. In case of any inconsistency or conflict between information in this document and such terms and conditions, the latter will prevail.

No offer to sell or license — Nothing in this document may be interpreted or construed as an offer to sell products that is open for acceptance or the grant, conveyance or implication of any license under any copyrights, patents or other industrial or intellectual property rights.

Quick reference data — The Quick reference data is an extract of the product data given in the Limiting values and Characteristics sections of this document, and as such is not complete, exhaustive or legally binding.

Trademarks

Notice: All referenced brands, product names, service names and trademarks are the property of their respective owners.

Contact information

For more information, please visit: <http://www.nxp.com>

For sales office addresses, please send an email to: salesaddresses@nxp.com

Revision history

Table 1. Revision history

Document ID	Release date	Data sheet status	Change notice	Supersedes
PESDXS2UQ_SER_N_3	20080911	Product data sheet	-	PESDXS2UQ_SERIES_2
Modifications:		<ul style="list-style-type: none"> Asterisks and note 1 removed in Marking Table 		
PESDXS2UQ_SERIES_2	20040427	Product specification	-	PESDXS2UQ_SERIES_1
PESDXS2UQ_SERIES_1	20031215	Product specification	-	-

Please be aware that important notices concerning this document and the product(s) described herein, have been included in section 'Legal information'.



© NXP B.V. 2008.

All rights reserved.

For more information, please visit: <http://www.nxp.com>

For sales office addresses, please send an email to: salesaddresses@nxp.com

Date of release: 11 September 2008

Document identifier: PESDXS2UQ_SER_N_3