

## AC Line Rated Disc Capacitors Class X1, 440 V<sub>AC</sub>, Class Y2, 300 V<sub>AC</sub>

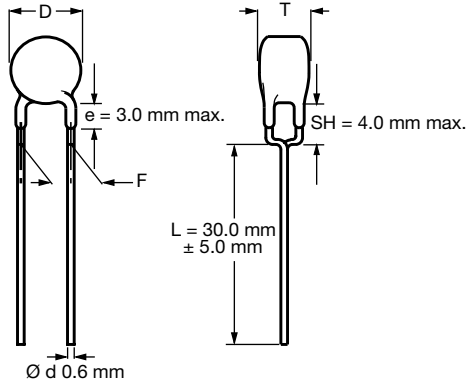

Capacitors with 5.0 mm, 7.5 mm and 10 mm lead spacing

QUICK REFERENCE DATA						
DESCRIPTION	CLASS X1 (U2J)	CLASS X1 (Y5S)	CLASS X1 (Y5U)	CLASS Y2 (U2J)	CLASS Y2 (Y5S)	CLASS Y2 (Y5U)
Voltage (V <sub>AC</sub> )	440			300		
Min. Capacitance (pF)	10	68	680	10	68	680
Max. Capacitance (pF)	47	680	10 000	47	680	10 000
Mounting	Through hole					

### OPERATING TEMPERATURE RANGE

- 40 °C to + 125 °C

### TEMPERATURE CHARACTERISTICS

See Ordering Information Tables

### CLIMATIC CATEGORY

40/125/21 according to EN 60068-1

### COATING

According to UL 94 V-0

Epoxy resin, isolating, flame retardant

### APPROVALS

ENEC - VDE DE 1-30691

UL 1414 file E183844

CSA 22.2

### PACKAGING

Bulk; tape and reel; taped ammpack

### FEATURES

- Complying with IEC 60384-14, 3<sup>rd</sup> edition
- High reliability
- Vertical (inline) kinked or straight leads
- Compliant to RoHS directive 2002/95/EC and in accordance to WEEE 2002/96/EC
- Halogen-free according to IEC 61249-2-21 definition



**RoHS**  
COMPLIANT  
HALOGEN  
**FREE**  
Available

### APPLICATIONS

- Across-the-line
- Line by-pass
- Antenna coupling

### DESIGN

The capacitors consist of a ceramic disc both sides of which are silver-plated. Connection leads are made of tinned copper having a diameter of 0.6 mm.

The capacitors may be supplied with vertical (inline) kinked leads having a lead spacing of 5.0 mm, 7.5 mm, or 10.0 mm. Encapsulation is made of flammable resistant epoxy resin in accordance with "UL 94 V-0"

### CAPACITANCE RANGE

10 pF to 0.01 µF

### RATED VOLTAGE U<sub>R</sub>

IEC 60384-14.2:

(X1): 440 V<sub>AC</sub>, 50 Hz

(Y2): 300 V<sub>AC</sub>, 50 Hz

### TEST VOLTAGE

Component test (100 %)

2600 V<sub>AC</sub>, 50 Hz, 2 s

(2600 V<sub>AC</sub> for LS 7.5 mm and 10 mm)

(2200 V<sub>AC</sub> for LS 5.0 mm)

Random sampling test (destructive test)

2600 V<sub>AC</sub>, 50 Hz, 60 s

Voltage proof of coating (destructive test)

2600 V<sub>AC</sub>, 50 Hz, 60 s

### INSULATION RESISTANCE

10 000 MΩ minimum

### TOLERANCE OF CAPACITANCE

± 20 % (code M); ± 10 % (code K)

### DISSIPATION FACTOR

2.5 % maximum

The capacitors meet the essential requirements of "EIA 198". Unless stated otherwise all electrical values apply at an ambient temperature of 25 °C ± 3 °C, at normal atmospheric conditions

ORDERING INFORMATION								
C (pF)	TOL. (%)	TEMP. COEFFICIENT	BODY DIAMETER D <sub>MAX.</sub> (mm)	BODY THICKNESS T <sub>MAX.</sub> (mm)	LEAD SPACING F (mm)	COATING EXTENSION e <sub>MAX.</sub> (2) (mm)	CLEAR TEXT CODE	
							15 <sup>TH</sup> DIGIT: T = REEL; U = AMMO; 3 = BULK (1)	
							RoHS COMPLIANT	RoHS AND HALOGEN-FREE
VY2 for leadspacing 5.0 mm						2200 V <sub>AC</sub> , 50 Hz, 2 s		
10	± 10	U2J (N750)	7.5	5.0	5.0	3.0	VY2100K29U2JS6*V5	VY2100K29U2JG6*V5
15							VY2150K29U2JS6*V5	VY2150K29U2JG6*V5
22							VY2220K29U2JS6*V5	VY2220K29U2JG6*V5
33							VY2330K29U2JS6*V5	VY2330K29U2JG6*V5
47							VY2470K29U2JS6*V5	VY2470K29U2JG6*V5
68							VY2680K29Y5SS6*V5	VY2680K29Y5SG6*V5
100							VY2101K29Y5SS6*V5	VY2101K29Y5SG6*V5
150							VY2151K29Y5SS6*V5	VY2151K29Y5SG6*V5
220							VY2221K29Y5SS6*V5	VY2221K29Y5SG6*V5
330							VY2331K29Y5SS6*V5	VY2331K29Y5SG6*V5
470	VY2471K29Y5SS6*V5	VY2471K29Y5SG6*V5						
680	± 20	Y5U (2E3)	8.0	5.0	5.0	3.0	VY2681M29Y5US6*V5	VY2681M29Y5UG6*V5
1000							VY2102M29Y5US6*V5	VY2102M29Y5UG6*V5
1500							VY2152M31Y5US6*V5	VY2152M31Y5UG6*V5
2200							VY2222M35Y5US6*V5	VY2222M35Y5UG6*V5
3300							VY2332M41Y5US6*V5	VY2332M41Y5UG6*V5
3900							VY2392M43Y5US6*V5	VY2392M43Y5UG6*V5
							VY2102M29Y5US6*V5	VY2102M29Y5UG6*V5
							VY2152M31Y5US6*V5	VY2152M31Y5UG6*V5

ORDERING INFORMATION								
C (pF)	TOL. (%)	TEMP. COEFFICIENT	BODY DIAMETER D <sub>MAX.</sub> (mm)	BODY THICKNESS T <sub>MAX.</sub> (mm)	LEAD SPACING F (mm)	COATING EXTENSION e <sub>MAX.</sub> (2) (mm)	CLEAR TEXT CODE	
							15 <sup>TH</sup> DIGIT: T = REEL; U = AMMO; 3 = BULK (1)	
							RoHS COMPLIANT	RoHS AND HALOGEN-FREE
VY2 for leadspacing 7.5 mm						2600 V <sub>AC</sub> , 50 Hz, 2 s		
10	± 10	U2J (N750)	7.5	5.0	7.5	3.0	VY2100K29U2JS6*V7	VY2100K29U2JG6*V7
15							VY2150K29U2JS6*V7	VY2150K29U2JG6*V7
22							VY2220K29U2JS6*V7	VY2220K29U2JG6*V7
33							VY2330K29U2JS6*V7	VY2330K29U2JG6*V7
47							VY2470K29U2JS6*V7	VY2470K29U2JG6*V7
68							VY2680K29Y5SS6*V7	VY2680K29Y5SG6*V7
100							VY2101K29Y5SS6*V7	VY2101K29Y5SG6*V7
150							VY2151K29Y5SS6*V7	VY2151K29Y5SG6*V7
220							VY2221K29Y5SS6*V7	VY2221K29Y5SG6*V7
330							VY2331K29Y5SS6*V7	VY2331K29Y5SG6*V7
470	VY2471K29Y5SS6*V7	VY2471K29Y5SG6*V7						
680	± 20	Y5U (2E3)	8.0	5.0	7.5	3.0	VY2681M29Y5US6*V7	VY2681M29Y5UG6*V7
1000							VY2102M29Y5US6*V7	VY2102M29Y5UG6*V7
1500							VY2152M31Y5US6*V7	VY2152M31Y5UG6*V7
2200							VY2222M35Y5US6*V7	VY2222M35Y5UG6*V7
3300							VY2332M41Y5US6*V7	VY2332M41Y5UG6*V7
3900							VY2392M43Y5US6*V7	VY2392M43Y5UG6*V7
4700							VY2472M49Y5US6*V7	VY2472M49Y5UG6*V7
6800							VY2682M59Y5US63V7	VY2682M59Y5UG63V7
0.01 µF			16.0				VY2103M63Y5US63V7	VY2103M63Y5UG63V7

ORDERING INFORMATION							CLEAR TEXT CODE	
C (pF)	TOL. (%)	TEMP. COEFFICIENT	BODY DIAMETER D <sub>MAX.</sub> (mm)	BODY THICKNESS T <sub>MAX.</sub> (mm)	LEAD SPACING F (mm)	COATING EXTENSION e <sub>MAX.</sub> (3) (mm)	15 <sup>TH</sup> DIGIT: T = REEL; U = AMMO; 3 = BULK (1)	
							RoHS COMPLIANT	RoHS AND HALOGEN-FREE
<b>VY2 for leadspacing 10.0 mm</b>							<b>2600 V<sub>AC</sub>, 50 Hz, 2 s</b>	
10	± 10	U2J (N750)	7.5	5.0	10.0	3.0	VY2100K29U2JS6*V0	VY2100K29U2JG6*V0
15							VY2150K29U2JS6*V0	VY2150K29U2JG6*V0
22							VY2220K29U2JS6*V0	VY2220K29U2JG6*V0
33							VY2330K29U2JS6*V0	VY2330K29U2JG6*V0
47							VY2470K29U2JS6*V0	VY2470K29U2JG6*V0
68							VY2680K29Y5SS6*V0	VY2680K29Y5SG6*V0
100							VY2101K29Y5SS6*V0	VY2101K29Y5SG6*V0
150							VY2151K29Y5SS6*V0	VY2151K29Y5SG6*V0
220							VY2221K29Y5SS6*V0	VY2221K29Y5SG6*V0
330							VY2331K29Y5SS6*V0	VY2331K29Y5SG6*V0
470	VY2471K29Y5SS6*V0	VY2471K29Y5SG6*V0						
680	± 20	Y5U (2E3)	8.0	5.0	10.0	3.0	VY2681M29Y5US6*V0	VY2681M29Y5UG6*V0
1000							VY2102M29Y5US6*V0	VY2102M29Y5UG6*V0
1500							VY2152M31Y5US6*V0	VY2152M31Y5UG6*V0
2200							VY2222M35Y5US6*V0	VY2222M35Y5UG6*V0
3300							VY2332M41Y5US6*V0	VY2332M41Y5UG6*V0
3900							VY2392M43Y5US6*V0	VY2392M43Y5UG6*V0
4700							VY2472M49Y5US6*V0	VY2472M49Y5UG6*V0
6800							VY2682M59Y5US63V0	VY2682M59Y5UG63V0
0.01 μF							VY2103M63Y5US63V0	VY2103M63Y5UG63V0

**Notes**

- (1) 15<sup>th</sup> digit of the clear text code number to be completed with the packaging code.
  - (2) On request available: ± 10 % tolerance for capacitance value 680 pF.
  - (3) On request available: ± 10 % tolerance for capacitance value 680 pF.
- Straight leads are available on request.

**LEADSPACING 10.0 mm**

PACKAGING					
CAPACITANCE VALUE	SIZE CODE	BODY DIAMETER D <sub>MAX.</sub> (mm)	PACKAGING QUANTITIES		
			BULK	REEL	AMMO
10 pF to 4700 pF	29 to 49	12.5	1000	1000	1000
6800 pF to 0.01 μF	59 to 63	16.0	500	-	-

**LEADSPACING 10.0 mm**

PACKAGING					
CAPACITANCE VALUE	SIZE CODE	BODY DIAMETER D <sub>MAX.</sub> (mm)	PACKAGING QUANTITIES		
			BULK	REEL	AMMO
10 pF to 4700 pF	29 to 49	12.5	1000	500	750
6800 pF to 0.01 μF	59 to 63	16.0	500	500	750

**Note**

- The capacitors are supplied in bulk packaging (cardboard boxes), in tape on reel in ammopack

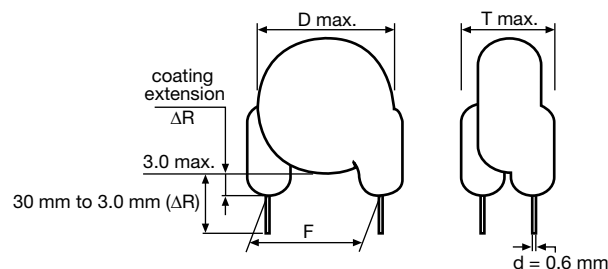
**STRAIGHT LEADS**

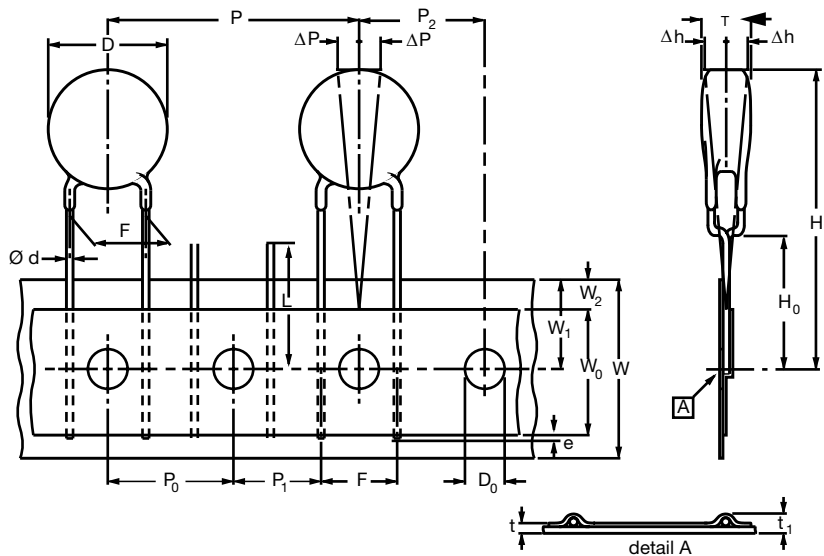

Inline kink (V) leaded capacitors on tape, lead spacing 5.0 mm (0.20"), 7.5 mm (0.30") and 10 mm (0.40")

DIMENSION OF TAPE				
SYMBOL	PARAMETER	DIMENSIONS (mm)		
		FIG.1 5 mm	FIG.1 7.5 mm	FIG.2 10 mm
D <sup>(1)</sup>	Body diameter	11.0 max.	14.0 max.	16.0 max.
d	Lead diameter	0.6 ± 0.05	0.6 ± 0.05	0.6 ± 0.05
P	Pitch of component	12.7 ± 1	15.0 ± 1	25.4 ± 1
P <sub>0</sub> <sup>(2)</sup>	Pitch of sprocket hole	12.7 ± 0.3	15.0 ± 0.3	12.7 ± 0.3
P <sub>1</sub> <sup>(3)</sup>	Distance, hole center to lead	3.85 ± 0.7	3.75 ± 0.7	7.7 ± 1.0
P <sub>2</sub> <sup>(3)</sup>	Distance, hole to center of component	6.35 ± 1.3	7.5 ± 1.5	12.7 ± 1.5
F	Lead spacing	5.0 (+ 0.6/- 0.4)	7.5 (+ 0.6/- 0.4)	10.0 (+ 0.6/- 0.4)
Δh	Average deviation across tape	± 1.0 max.	± 1.0 max.	± 1.0 max.
ΔP	Average deviation in direction of reeling	± 1.0 max.	± 1.0 max.	± 1.0 max.
W	Carrier tape width	18.0 + 1/- 0.5	18.0 + 1/- 0.5	18.0 + 1/- 0.5
W <sub>0</sub>	Hold-down tape width	5.0 min.	5.0 min.	5.0 min.
W <sub>1</sub>	Position of sprocket hole	9.0 + 0.75 - 0.5	9.0 + 0.75 - 0.5	9.0 + 0.75 - 0.5
W <sub>2</sub>	Distance of hold-down tape	3.0 max.	3.0 max.	3.0 max.
H <sub>1</sub>	Maximum component height	32	40	40
H <sub>0</sub>	Height to seating plane (for kinked leads)	16.0 ± 0.5	16.0 ± 0.5	16.0 ± 0.5
H <sub>0</sub>	Height to seating plane (for straight leads)	20.0 ± 0.5	20.0 ± 0.5	20.0 ± 0.5
L	Length of cut leads	11.0 max.	11.0 max.	11.0 max.
l	Length of lead protrusion	1.0 max.	1.0 max.	1.0 max.
D <sub>0</sub>	Diameter of sprocket hole	4.0 ± 0.2	4.0 ± 0.2	4.0 ± 0.2
t	Total tape thickness	0.9 max.	0.9 max.	0.9 max.

**Notes**

- (1) See ordering information table
- (2) Cumulative pitch error: ± ≤ 1 mm/20 pitches
- (3) Obliquity maximum 3°



**REEL AND TAPE DATA** in millimeters

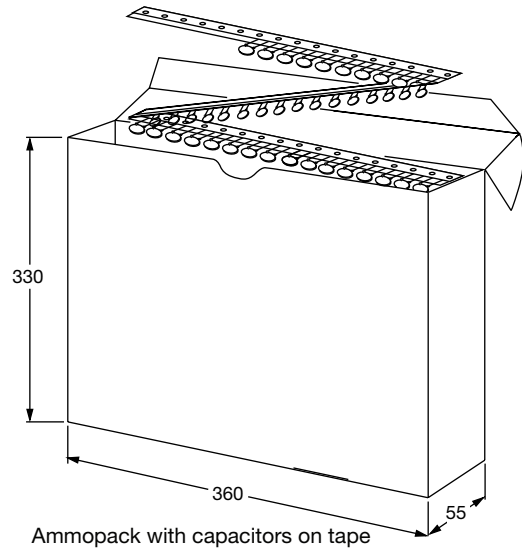
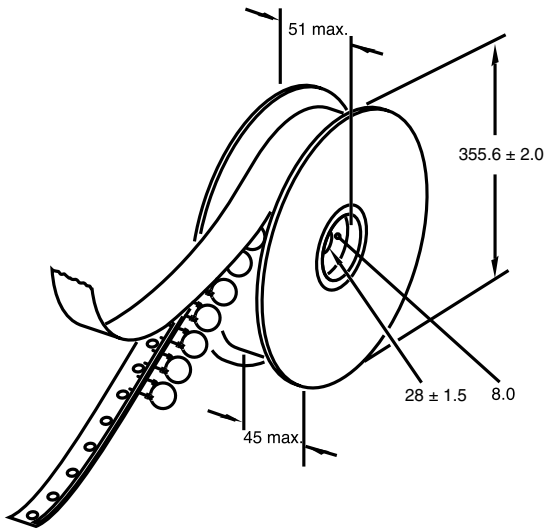



**STANDARD RECOGNITION**

IEC 60384 - 14/3rd issue (2005)- Safety Tests  
UL 1414 - Across-the-line, antenna-coupling and line-by-pass component  
CQC - China Quality Certification Centre-Safety Tests

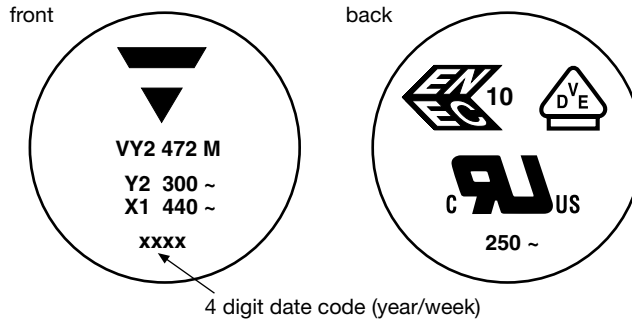
**MARKING: 2 SIDES  
(EXAMPLE)**



**LABEL  
(EXAMPLE)**





PN: VY2331K29Y5SS6UV7    Lot1: 14Z549306    DC1: 0601  
 QTY: 1000    Lot2:    DC2:  
 PO:    Batch: 200601CN  
 SO:    Region: 9520    SL: 0010  
 Ser.No: 0601H72383

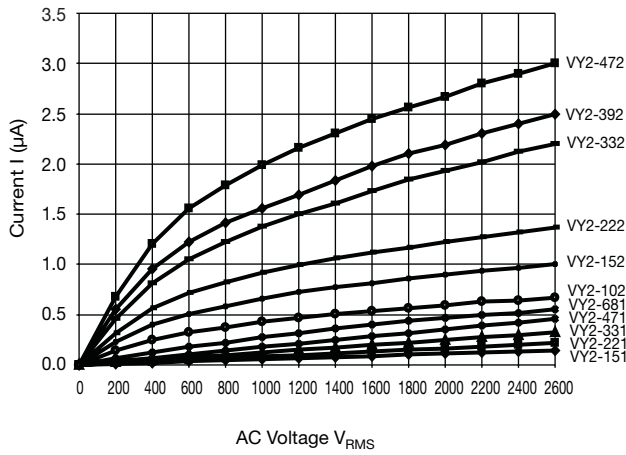

2/5

Typical Current vs. Voltage (Leakage Current) at 60 Hz 25 °C



Typical Current vs. Voltage (Leakage Current) at 60 Hz 25 °C

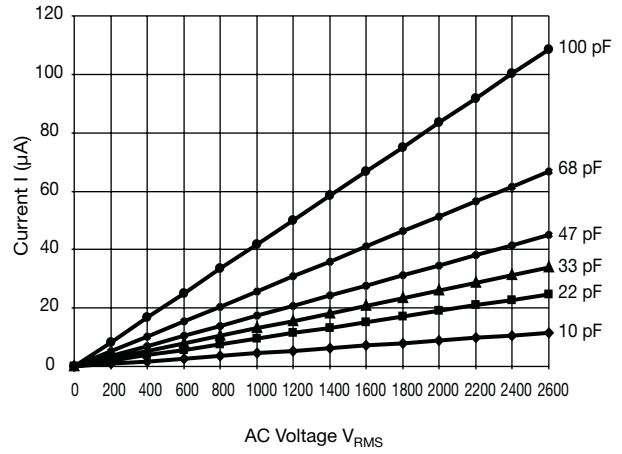

**Note**

- The capacitors meet the essential requirements of EIA 198. Unless stated otherwise all electrical values apply at an ambient temperature of 25 °C ± 3 °C, at normal atmospheric conditions.



## Disclaimer

ALL PRODUCT, PRODUCT SPECIFICATIONS AND DATA ARE SUBJECT TO CHANGE WITHOUT NOTICE TO IMPROVE RELIABILITY, FUNCTION OR DESIGN OR OTHERWISE.

Vishay Intertechnology, Inc., its affiliates, agents, and employees, and all persons acting on its or their behalf (collectively, "Vishay"), disclaim any and all liability for any errors, inaccuracies or incompleteness contained in any datasheet or in any other disclosure relating to any product.

Vishay makes no warranty, representation or guarantee regarding the suitability of the products for any particular purpose or the continuing production of any product. To the maximum extent permitted by applicable law, Vishay disclaims (i) any and all liability arising out of the application or use of any product, (ii) any and all liability, including without limitation special, consequential or incidental damages, and (iii) any and all implied warranties, including warranties of fitness for particular purpose, non-infringement and merchantability.

Statements regarding the suitability of products for certain types of applications are based on Vishay's knowledge of typical requirements that are often placed on Vishay products in generic applications. Such statements are not binding statements about the suitability of products for a particular application. It is the customer's responsibility to validate that a particular product with the properties described in the product specification is suitable for use in a particular application. Parameters provided in datasheets and/or specifications may vary in different applications and performance may vary over time. All operating parameters, including typical parameters, must be validated for each customer application by the customer's technical experts. Product specifications do not expand or otherwise modify Vishay's terms and conditions of purchase, including but not limited to the warranty expressed therein.

Except as expressly indicated in writing, Vishay products are not designed for use in medical, life-saving, or life-sustaining applications or for any other application in which the failure of the Vishay product could result in personal injury or death. Customers using or selling Vishay products not expressly indicated for use in such applications do so at their own risk and agree to fully indemnify and hold Vishay and its distributors harmless from and against any and all claims, liabilities, expenses and damages arising or resulting in connection with such use or sale, including attorneys fees, even if such claim alleges that Vishay or its distributor was negligent regarding the design or manufacture of the part. Please contact authorized Vishay personnel to obtain written terms and conditions regarding products designed for such applications.

No license, express or implied, by estoppel or otherwise, to any intellectual property rights is granted by this document or by any conduct of Vishay. Product names and markings noted herein may be trademarks of their respective owners.