

CG series Chip Type, Higher Capacitance

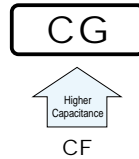

- Higher Capacitance, Low ESR, High ripple current.
- Load life of 2000 hours at 105°C.
- SMD type : Lead free reflow soldering condition at 260°C peak correspondence.
- Compliant to the RoHS directive (2002/95/EC).



Specifications

Item	Performance Characteristics									
Category Temperature Range	-55 to +105°C									
Rated Voltage Range	2.5 to 16V									
Rated Capacitance Range	47 to 3300μF									
Capacitance Tolerance	±20% at 120Hz, 20°C									
Tangent of loss angle (tan δ)	Less than or equal to the specified value at 120Hz, 20°C									
ESR (※ 1)	Less than or equal to the specified value at 100kHz, 20°C									
Leakage Current (※ 2)	Less than or equal to the specified value. After 2 minutes' application of rated voltage at 20°C									
Temperature Characteristics (Max.Impedance Ratio)	Z+105°C / Z+20°C ≤ 1.25 (100kHz) Z-55°C / Z+20°C ≤ 1.25									
Endurance	The specifications listed at right shall be met when the capacitors are restored to 20°C after the rated voltage is applied for 2000 hours at 105°C.	<table border="1"> <tr><td>Capacitance change</td><td>Within ± 20% of the initial capacitance value (※ 3)</td></tr> <tr><td>tan δ</td><td>150% or less than the initial specified value</td></tr> <tr><td>ESR (※ 1)</td><td>150% or less than the initial specified value</td></tr> <tr><td>Leakage current (※ 2)</td><td>Less than or equal to the initial specified value</td></tr> </table>	Capacitance change	Within ± 20% of the initial capacitance value (※ 3)	tan δ	150% or less than the initial specified value	ESR (※ 1)	150% or less than the initial specified value	Leakage current (※ 2)	Less than or equal to the initial specified value
Capacitance change	Within ± 20% of the initial capacitance value (※ 3)									
tan δ	150% or less than the initial specified value									
ESR (※ 1)	150% or less than the initial specified value									
Leakage current (※ 2)	Less than or equal to the initial specified value									
Damp Heat (Steady State)	The specifications listed at right shall be met when the capacitors are restored to 20°C after the rated voltage is applied for 1000 hours at 60°C, 90% RH.	<table border="1"> <tr><td>Capacitance change</td><td>Within ± 20% of the initial capacitance value (※ 3)</td></tr> <tr><td>tan δ</td><td>150% or less than the initial specified value</td></tr> <tr><td>ESR (※ 1)</td><td>150% or less than the initial specified value</td></tr> <tr><td>Leakage current (※ 2)</td><td>Less than or equal to the initial specified value</td></tr> </table>	Capacitance change	Within ± 20% of the initial capacitance value (※ 3)	tan δ	150% or less than the initial specified value	ESR (※ 1)	150% or less than the initial specified value	Leakage current (※ 2)	Less than or equal to the initial specified value
Capacitance change	Within ± 20% of the initial capacitance value (※ 3)									
tan δ	150% or less than the initial specified value									
ESR (※ 1)	150% or less than the initial specified value									
Leakage current (※ 2)	Less than or equal to the initial specified value									
Resistance to Soldering Heat	After soldering the capacitor under the soldering conditions prescribed here, the capacitor shall meet the specifications listed at right, provided that it's temperature profile is measured at the capacitor top and the terminal. Pre-heating shall be done at 150 to 200°C and for 60 to 180 sec. The duration for over +230°C temperature at capacitor surface shall not exceed 60 seconds. In the case of peak temp, less than 250°C, reflow soldering shall be two times maximum. In the case of peak temp, less than 260°C, reflow soldering shall be once. Measurement for solder temperature profile shall be made at the capacitor top and the terminal.	<table border="1"> <tr><td>Capacitance change</td><td>Within ± 10% of the initial capacitance value (※ 3)</td></tr> <tr><td>tan δ</td><td>130% or less than the initial specified value</td></tr> <tr><td>ESR (※ 1)</td><td>130% or less than the initial specified value</td></tr> <tr><td>Leakage current (※ 2)</td><td>Less than or equal to the initial specified value</td></tr> </table>	Capacitance change	Within ± 10% of the initial capacitance value (※ 3)	tan δ	130% or less than the initial specified value	ESR (※ 1)	130% or less than the initial specified value	Leakage current (※ 2)	Less than or equal to the initial specified value
Capacitance change	Within ± 10% of the initial capacitance value (※ 3)									
tan δ	130% or less than the initial specified value									
ESR (※ 1)	130% or less than the initial specified value									
Leakage current (※ 2)	Less than or equal to the initial specified value									
Marking	Navy blue print on the case top									

- ※ 1 ESR should be measured at both of the terminal ends closest where the terminals protrude through the plastic platform.
- ※ 2 Conditioning : If any doubt arises, measure the leakage current after the voltage treatment of applying DC rated voltage continuously to the capacitor for 120 minutes at 105°C.
- ※ 3 Initial value : The value before test of examination of resistance to soldering.

Dimensions

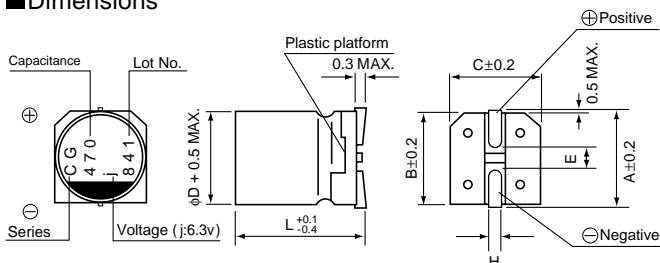

	(mm)					
Size	φ5 × 6L	φ6.3 × 6L	φ8 × 7L	φ10 × 8L	φ10 × 10L	φ10 × 12.7L
φD	5.0	6.3	8.0	10.0	10.0	10.0
L	5.9	5.9	6.9	7.9	9.9	12.6
A	6.0	7.3	9.0	11.0	11.0	11.0
B	5.3	6.6	8.3	10.3	10.3	10.3
C	5.3	6.6	8.3	10.3	10.3	10.3
E	1.6	2.1	3.2	4.6	4.6	4.6
H	0.5 to 0.8	0.5 to 0.8	0.8 to 1.1	0.8 to 1.1	0.8 to 1.1	0.8 to 1.1

Type numbering system (Example : 6.3V 470μF)

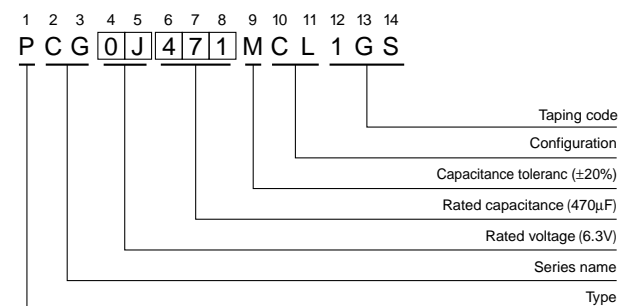

Voltage

V	2.5	4	6.3	10	16
Code	e	g	j	A	C

• Dimension table in next page.



■ Standard Ratings

Rated Voltage (V)(code)	Surge Voltage (V)	Rated Capacitance (μF)	Case Size φD × L (mm)	tan δ	Leakage Current (μA)	ESR (mΩ) (at 100kHz 20°C)	Rated Ripple (mArms)	Part Number
2.5 (0E)	2.8	220	5 × 6	0.12	110	30	2100	PCG0E221MCL1GS
		470	6.3 × 6	0.12	235	20	2900	PCG0E471MCL1GS
		560	6.3 × 6	0.12	280	20	3000	PCG0E561MCL1GS
		820	8 × 7	0.12	410	20	3300	PCG0E821MCL1GS
		1500	10 × 8	0.12	750	17	4100	PCG0E152MCL1GS
		2700	10 × 10	0.12	1350	12	4700	PCG0E272MCL1GS
		3300	10 × 12.7	0.12	1650	10	5500	PCG0E332MCL1GS
4 (0G)	4.6	180	5 × 6	0.12	144	32	1900	PCG0G181MCL1GS
		390	6.3 × 6	0.12	312	22	2700	PCG0G391MCL1GS
		680	8 × 7	0.12	544	21	3200	PCG0G681MCL1GS
		1200	10 × 8	0.12	960	17	4000	PCG0G122MCL1GS
		2200	10 × 10	0.12	1760	13	4600	PCG0G222MCL1GS
		2700	10 × 12.7	0.12	2160	11	5300	PCG0G272MCL1GS
6.3 (0J)	7.2	150	5 × 6	0.12	189	33	1800	PCG0J151MCL1GS
		270	6.3 × 6	0.12	340	23	2600	PCG0J271MCL1GS
		330	6.3 × 6	0.12	416	23	2700	PCG0J331MCL1GS
		470	8 × 7	0.12	592	22	3100	PCG0J471MCL1GS
		1000	10 × 8	0.12	1260	18	3800	PCG0J102MCL1GS
		1800	10 × 10	0.12	2268	14	4400	PCG0J182MCL1GS
		2200	10 × 12.7	0.12	2772	12	5000	PCG0J222MCL1GS
10 (1A)	11.5	82	5 × 6	0.12	164	35	1700	PCG1A820MCL1GS
		150	6.3 × 6	0.12	300	25	2500	PCG1A151MCL1GS
		330	8 × 7	0.12	660	23	3100	PCG1A331MCL1GS
		560	10 × 8	0.12	1120	20	3600	PCG1A561MCL1GS
		820	10 × 10	0.12	1640	15	4300	PCG1A821MCL1GS
		1000	10 × 12.7	0.12	2000	13	4800	PCG1A102MCL1GS
16 (1C)	18.4	47	5 × 6	0.12	150	40	1500	PCG1C470MCL1GS
		82	6.3 × 6	0.12	262	30	2300	PCG1C820MCL1GS
		150	8 × 7	0.12	480	28	2800	PCG1C151MCL1GS
		270	10 × 8	0.12	864	25	3300	PCG1C271MCL1GS
		470	10 × 10	0.12	1504	20	3700	PCG1C471MCL1GS
		680	10 × 12.7	0.12	2176	18	4100	PCG1C681MCL1GS

Rated ripple current (mArms) at 105°C 100kHz

- Taping specifications are given in page 23.
- Recommended land size, soldering by reflow are given in page 18, 19.
- Please refer to page 3 for the minimum order quantity.