

LMP7721 Evaluation Board

National Semiconductor
Application Note 1796
April 16, 2009



The LMP7721 Evaluation Board provides a platform to test the input bias current and performance of the LMP7721 amplifier. The LMP7721 amplifier is optimized for ultra low input bias current, 3 fA typical, by using on chip guard drivers and

a package pin out to isolate the amplifier's inputs from its power supply and output pins.

Figure 1 is the schematic diagram for the LMP7721 evaluation board:

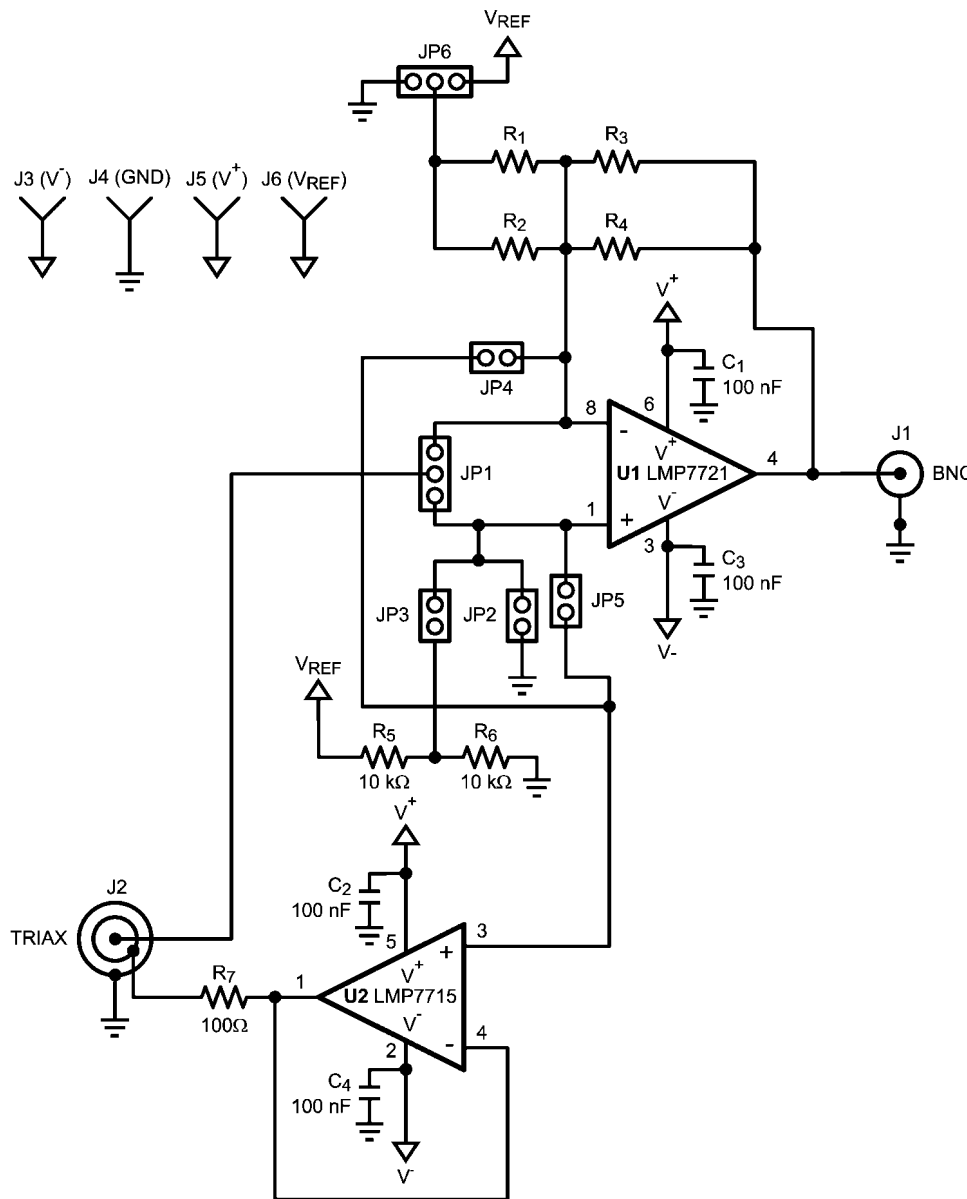

FIGURE 1. LMP7721 Evaluation Board

30054001

The evaluation board is design to be compatible with the 1 fA input bias current of the LMP7721 by providing a guarded area around the input puts of the amplifier. The input guard creates an equal potential zone around the input pins that prevents leakage currents from other parts of the PCB from reaching the input pins and causing an error current. A description of the board's features follows:

Power Supply Connections

J3, J4 and J5 are the power supply connections. The power supply can be a single supply with a range 1.8 to 5.5 volts. Also, a split supply voltage can be used with the with the condition that $1.8 \text{ volts} \leq V^+ - (V^-) \leq 5.5 \text{ volts}$.

For single supply operation, J3 and J4 are connected together and is the ground connection. The positive supply voltage connection is J5.

For split-supply operation, the negative supply voltage is connected to J3. The positive supply voltage is connected to J5 and the ground (or common) connection of the supplies is connected to J4.

Reference Voltage Connection

(V_{REF})

The LMP7721 can be configured as an inverting amplifier or a non-inverting amplifier. In each case, it may be required to provide a level shift voltage to keep the output voltage within a specified range and is accomplished by using the V_{REF} connection. Jumper JP3 is used to connect the V_{REF} to the non-inverting input of U1 when U1 is used in an inverting amplifier configuration. Jumper JP6 is used to connect the V_{REF} to the inverting input of U1 when U1 is used in a non-inverting amplifier configuration.

Components R_1 , R_2 , R_3 , R_4 , R_5 , R_6 and R_7

These components are shown, as resistors on the schematic are not mounted on the board. This evaluation board uses pin sockets at the location of these components to give the user the freedom to configure the LMP7721 amplifier to best fit the application being considered.

Jumper Functions

JP1 JP1 is used to connect the signal terminal of the triax connector (J2) to the inverting input or the non-inverting input of U1, the LMP7721 amplifier.

JP2 JP2 is used to connect the non-inverting input of U1 to ground.

JP3 JP3 is used to connect the non-inverting terminal of the LMP7721 to the V_{REF} voltage. The connection to V_{REF} can be direct by using a wire jumper in the position of R_5 , or through a voltage divider by using resistors in the positions of R_5 and R_6 .

JP4 JP4 is used to connect the guard and guard driver to the inverting terminal of the LMP7721 when it is the low impedance node. This is the case when the LMP7721 is used as a non-inverting amplifier.

JP5 JP5 is used to connect the guard and guard driver to the non-inverting terminal of the LMP7721 when it is the low impedance node. This is the case when the LMP7721 is used as an inverting amplifier.

JP6 JP6 is used to connect the inverting terminal of the LMP7721 to the V_{REF} voltage or to ground. These is used when U1 is used as a non-inverting amplifier.

Input and output connectors

J1 J1 is a BNC connect and is the output of the LMP7721 amplifier

J2 J2 is a Triax connector and is used to connect a signal source to the input of the LMP7721. This component is not mounted on the board. A Triax connector is similar to a BNC connector but includes a shield between the central conductor and the outer shield and is referred to as a guard. A guard driver drives the guard to the same voltage as the center conductor, which minimizes any leakage currents in the connector or in the triax cable connected to it.

Example Applications

Non-inverting amplifier with a gain of two:

In this example a sensor such as a pH electrode is the signal source and the LMP7721 is being used to buffer and amplify the signal. The output of a pH electrode, at 25°C ranges from about +415 mV to -415 mV as the pH ranges from 0 to 14. The output impedance of a pH electrode is extremely high, greater then 5 to 10 M Ω , so the LMP7721 is an excellent amplifier to buffer the output of a pH electrode.

For this application, a ± 2.5 volt supply voltage will be used. The following schematic shows the placement of the jumpers and components.

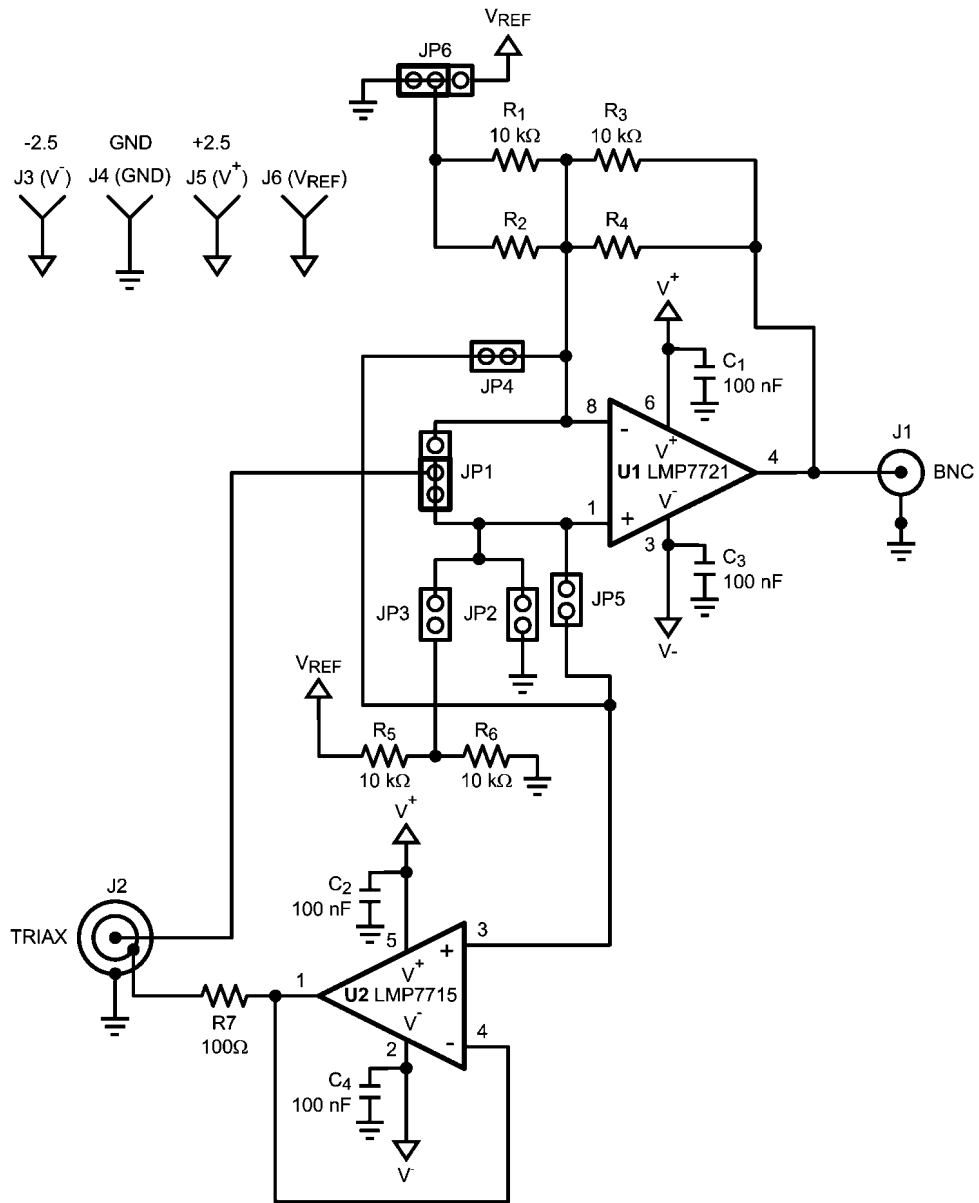

30054002

FIGURE 2.

Transimpedance Amplifier (Inverting Amplifier with Level Shift)

In this application, the LMP7721 is used as a transimpedance amplifier that converts the current generated in the pin diode

by light, or other radiation source, to a voltage at the amplifiers output. The input is biased to 2.5 volts by the V_{REF} and the resistive divider R_5 and R_6 . Current from the Pin Diode will generate a voltage at the amplifier's output equal to $(I_{pin-diode}) \times (R_3)$.

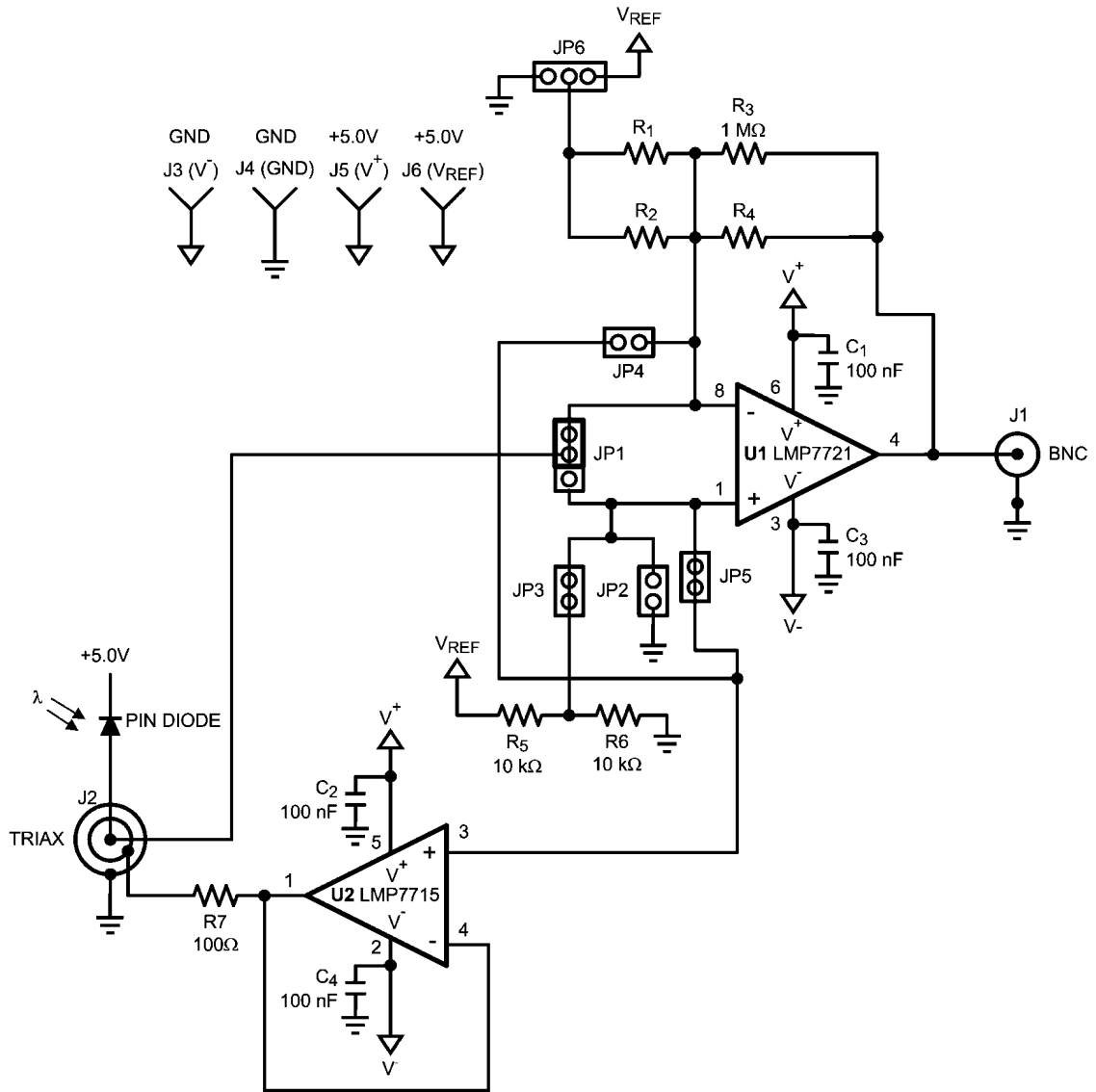

FIGURE 3.

30054003

The table below shows the Bill of Material (BOM) of the evaluation board.

Designator	Description	Comment
J5	Jack connector	red
J3	Jack connector	green
J4	Jack connector	black
J6	Jack connector	yellow
C1 — C4	0805 capacitor	100 nF
J1	BNC	
JP1, JP6	3 pin header	
JP2 — JP5	2 pin header	
U1	LMP7721MA	8-Pin SOIC
U2	LMP7715MF	5-Pin SOT-23
R1 — R7	Leaded resistor	not stuffed
J2	Triax connector	not stuffed
No Designator	PC pin receptacle	For R1 — R7
No Designator	1/2", 4-40 nylon threaded standoff	Qty. 4
No Designator	3/8", 4-40 Screw	Qty. 4

Notes

For more National Semiconductor product information and proven design tools, visit the following Web sites at:

Products		Design Support	
Amplifiers	www.national.com/amplifiers	WEBENCH® Tools	www.national.com/webench
Audio	www.national.com/audio	App Notes	www.national.com/appnotes
Clock and Timing	www.national.com/timing	Reference Designs	www.national.com/refdesigns
Data Converters	www.national.com/adc	Samples	www.national.com/samples
Interface	www.national.com/interface	Eval Boards	www.national.com/evalboards
LVDS	www.national.com/lvds	Packaging	www.national.com/packaging
Power Management	www.national.com/power	Green Compliance	www.national.com/quality/green
Switching Regulators	www.national.com/switchers	Distributors	www.national.com/contacts
LDOs	www.national.com/ldo	Quality and Reliability	www.national.com/quality
LED Lighting	www.national.com/led	Feedback/Support	www.national.com/feedback
Voltage Reference	www.national.com/vref	Design Made Easy	www.national.com/easy
PowerWise® Solutions	www.national.com/powerwise	Solutions	www.national.com/solutions
Serial Digital Interface (SDI)	www.national.com/sdi	Mil/Aero	www.national.com/milaero
Temperature Sensors	www.national.com/tempsensors	SolarMagic™	www.national.com/solarmagic
Wireless (PLL/VCO)	www.national.com/wireless	Analog University®	www.national.com/AU

THE CONTENTS OF THIS DOCUMENT ARE PROVIDED IN CONNECTION WITH NATIONAL SEMICONDUCTOR CORPORATION ("NATIONAL") PRODUCTS. NATIONAL MAKES NO REPRESENTATIONS OR WARRANTIES WITH RESPECT TO THE ACCURACY OR COMPLETENESS OF THE CONTENTS OF THIS PUBLICATION AND RESERVES THE RIGHT TO MAKE CHANGES TO SPECIFICATIONS AND PRODUCT DESCRIPTIONS AT ANY TIME WITHOUT NOTICE. NO LICENSE, WHETHER EXPRESS, IMPLIED, ARISING BY ESTOPPEL OR OTHERWISE, TO ANY INTELLECTUAL PROPERTY RIGHTS IS GRANTED BY THIS DOCUMENT.

TESTING AND OTHER QUALITY CONTROLS ARE USED TO THE EXTENT NATIONAL DEEMS NECESSARY TO SUPPORT NATIONAL'S PRODUCT WARRANTY. EXCEPT WHERE MANDATED BY GOVERNMENT REQUIREMENTS, TESTING OF ALL PARAMETERS OF EACH PRODUCT IS NOT NECESSARILY PERFORMED. NATIONAL ASSUMES NO LIABILITY FOR APPLICATIONS ASSISTANCE OR BUYER PRODUCT DESIGN. BUYERS ARE RESPONSIBLE FOR THEIR PRODUCTS AND APPLICATIONS USING NATIONAL COMPONENTS. PRIOR TO USING OR DISTRIBUTING ANY PRODUCTS THAT INCLUDE NATIONAL COMPONENTS, BUYERS SHOULD PROVIDE ADEQUATE DESIGN, TESTING AND OPERATING SAFEGUARDS.

EXCEPT AS PROVIDED IN NATIONAL'S TERMS AND CONDITIONS OF SALE FOR SUCH PRODUCTS, NATIONAL ASSUMES NO LIABILITY WHATSOEVER, AND NATIONAL DISCLAIMS ANY EXPRESS OR IMPLIED WARRANTY RELATING TO THE SALE AND/OR USE OF NATIONAL PRODUCTS INCLUDING LIABILITY OR WARRANTIES RELATING TO FITNESS FOR A PARTICULAR PURPOSE, MERCHANTABILITY, OR INFRINGEMENT OF ANY PATENT, COPYRIGHT OR OTHER INTELLECTUAL PROPERTY RIGHT.

LIFE SUPPORT POLICY

NATIONAL'S PRODUCTS ARE NOT AUTHORIZED FOR USE AS CRITICAL COMPONENTS IN LIFE SUPPORT DEVICES OR SYSTEMS WITHOUT THE EXPRESS PRIOR WRITTEN APPROVAL OF THE CHIEF EXECUTIVE OFFICER AND GENERAL COUNSEL OF NATIONAL SEMICONDUCTOR CORPORATION. As used herein:

Life support devices or systems are devices which (a) are intended for surgical implant into the body, or (b) support or sustain life and whose failure to perform when properly used in accordance with instructions for use provided in the labeling can be reasonably expected to result in a significant injury to the user. A critical component is any component in a life support device or system whose failure to perform can be reasonably expected to cause the failure of the life support device or system or to affect its safety or effectiveness.

National Semiconductor and the National Semiconductor logo are registered trademarks of National Semiconductor Corporation. All other brand or product names may be trademarks or registered trademarks of their respective holders.

Copyright© 2009 National Semiconductor Corporation

For the most current product information visit us at www.national.com



**National Semiconductor
Americas Technical
Support Center**
Email: support@nsc.com
Tel: 1-800-272-9959

**National Semiconductor Europe
Technical Support Center**
Email: europe.support@nsc.com

**National Semiconductor Asia
Pacific Technical Support Center**
Email: ap.support@nsc.com

**National Semiconductor Japan
Technical Support Center**
Email: jpn.feedback@nsc.com