

Description

The ISL6700 General Purpose Design Tool (ISL6700EVAL1Z) is a very simple evaluation board which can help the user rapidly construct an isolated DC/DC converter in several configurations. The board consists of the Intersil ISL6700 Half-Bridge Driver IC, two Intersil IRFR120 MOSFETs, a bootstrap diode, a bootstrap capacitor and two input voltage decoupling capacitors. The ISL6700 can operate at frequencies in excess of 500kHz and has typical propagation delay times of 30ns. It has 1.25A output drive capability and can switch an IRFR120 load with rise and fall times of less than 20ns.

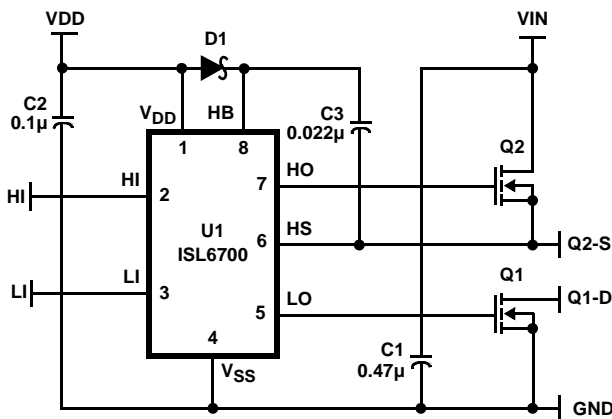

FIGURE 1. ISL6700EVAL1Z SCHEMATIC

Application Information

The ISL6700 General Purpose Design Tool (ISL6700EVAL1Z) is intended for users who have some experience in power converter design. The 80V rating of the ISL6700 makes it an ideal choice for many isolated DC/DC converters, which are point-of-load converters in a distributed power architecture. To insure adequate design margin, the maximum voltage that should be applied to this input should be less than 80VDC. Three possible application converters are described briefly as follows:

Application #1: Two-Switch Forward Converter

To use the ISL6700EVAL1Z as part of a two-switch forward converter, the user needs the configuration depicted in Figure 2. In this topology, both MOSFETs are turned on and off together, therefore, HI and LI are tied together. The input signal comes from a pulse-width modulator (PWM) controller, which is sensing the output voltage (and input switch current if current-mode control is used). The Schottky rectifiers clamp the reverse swing of the power transformer and must be rated to handle the input voltage.

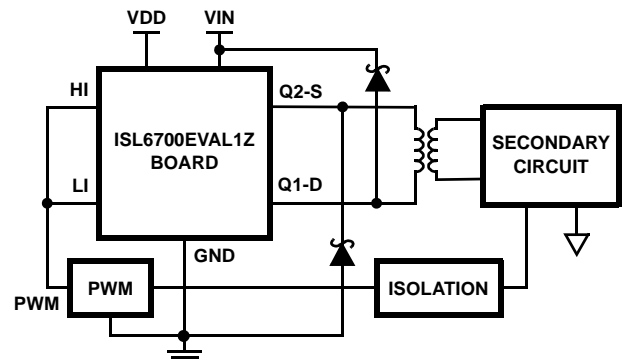

FIGURE 2. TWO-SWITCH FORWARD CONVERTER

Application #2: Half-Bridge Converter

To use the ISL6700EVAL1Z as part of a half-bridge converter, the user needs the configuration depicted in Figure 3. In this topology, the MOSFETs are driven alternately, with some dead time between turn-off of one and turn-on of the other. Therefore, HI and LI are driven with alternating signals PWM_A and PWM_B from the PWM controller.

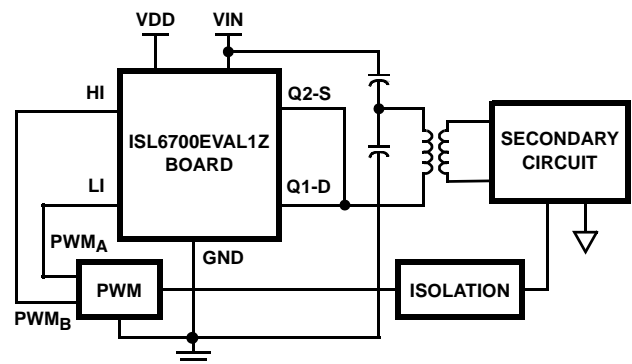

FIGURE 3. HALF-BRIDGE CONVERTER

Application #2: Active-Clamp Forward Converter

To use the ISL6700EVAL1Z as part of an active-clamp forward converter, the user needs the configuration depicted in Figure 4. In this topology, the MOSFETs are again driven alternately, and HI and LI need to be driven alternately as well. The high-side MOSFET (Q2 in the ISL6700EVAL1Z board), along with capacitor C_{RESET} , is used in this topology as a means to reset the power transformer in a lossless manner. This topology lends itself well to running at duty cycles exceeding 50%, unlike Applications 1 and 2.

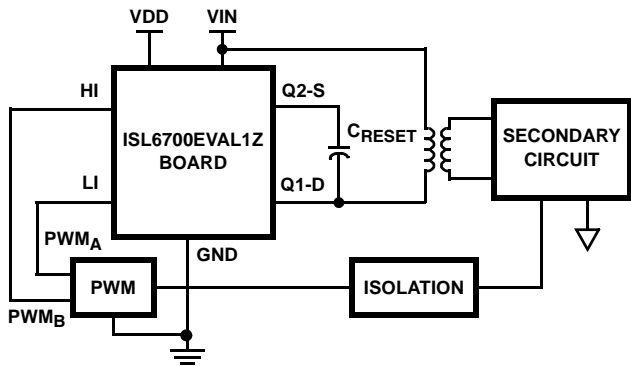

FIGURE 4. ACTIVE-CLAMP FORWARD CONVERTER

Additional Information

The applications previously highlighted, are three possible DC/DC converter topologies where the ISL6700 half-bridge driver can help simplify the design procedure and provide value to the designer and the end user. There are many other possible applications. More detailed information regarding the ISL6700 can be found in the Intersil data sheet.

ISL6700EVAL1Z Parts List

ITEM	QUANTITY	REFERENCE DESIGNATOR	DESCRIPTION	VENDOR	PART NUMBER
1	1	U1	IC, Half-Bridge Driver, 80V, 1.25A	Intersil	ISL6700IB
2	2	Q1, Q2	MOSFET, N-channel, 100V, 8.4A	Fairchild	IRFR120
3	1	D1	Diode, Schottky, 100V, 1A	On Semi	MBRS1100T3
4	1	C1	Capacitor, Ceramic, 0.47 μ F, 20%, 100V	AVX	22251C474MAT2A
4a (Note)	1	C1	Capacitor, Ceramic, 0.47 μ F, 20%, 200V	NIC	NMCH2225X7R474K200TR
5	1	C2	Capacitor, Ceramic, 0.1 μ F, 10%, 50V	AVX	12065C104KAT2A
6	1	C3	Capacitor, Ceramic, 0.022 μ F, 10%, 50V	AVX	12065C223KAT2A
7	8	TP1 thru TP8	Terminal, Solder, Turreted, Feed-thru	Cambion	160-2044-02-01-00
8	1	N/A	ISL6700EVAL1Z PCB	Intersil	ISL6700EVAL1ZREVAPCB

NOTE: Can be substituted for item #4.

Intersil Corporation reserves the right to make changes in circuit design, software and/or specifications at any time without notice. Accordingly, the reader is cautioned to verify that the Application Note or Technical Brief is current before proceeding.

For information regarding Intersil Corporation and its products, see www.intersil.com