

"Auto" Step Up - Plug In (176 Series)

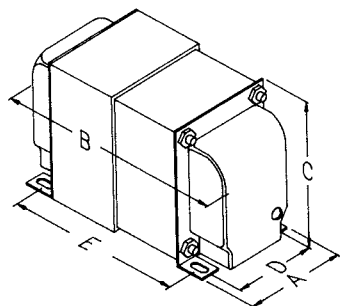

Line

Autotransformer Step Up - Plug In (115V to 230V)

- Single winding, does not provide isolation, for use where equipment is already isolated and only voltage change is required.
- World wide applications, 50 or 60 Hz. operation, step up (115VAC to 230VAC).
- Input is circuit breaker protected.
- Hi-pot tested to 2 KV RMS
- Standard 3-wire, grounded plug (can also be used with adaptors for proper grounding).
- Input is connected to a 5 foot cord & standard grounded 125V North American plug (NEMA 5-15P)
- Output is connected to a grounded North American 250V receptacle (NEMA 6-15R).
- North American Mark of Safety - C UL & UL listed (File #E211544)
- **Remember** - These units do NOT convert line frequency.

Part No.	Capacity VA	Dimensions (Inches)					Wt. Lbs.
		A	B	C	D	E	
176A	120	3.16	4.25	3.81	2.50	2.94	3.5
176B	200	3.16	4.50	3.81	2.50	3.19	4.5
176C	300	3.16	5.00	3.81	2.50	3.69	6
176D	500	3.80	6.00	4.68	3.00	4.38	10
176E	750	3.80	7.06	4.68	3.00	5.38	14
176F	1000	3.80	7.06	4.68	3.00	5.38	14.5
176G	1500	4.40	6.63	5.39	3.50	6.09	22



EUROPE

Basingstoke, UK 01256 812812

AUSTRALIA

Queenstown, Australia 61-8-8240-2244

www.hammondmfg.com



CANADA

Guelph, Ontario (519) 822-2960
St. Laurent, Quebec (514) 343-9010

USA

Cheektowaga, NY (716) 630-7030

