

REV. Status

REVISION - 11/08/01 MP
REVISION A ADDED A.11-A.13. 03/20/02 MP
REVISION B ADDED PAGE 2 RELIABILITY TEST 04/23/02 MP
REVISION C ADDED BAPT & TUV TO MARKING 05/09/02 MP
REVISION D DELETED BAPT 05/07/05 MP

TELECOMMUNICATION MODEM COUPLING TRANSFORMER FOR WET APPLICATION

- A. Electrical Specifications (@ 25°C)
- Pri Source Impedance; 600Ω
 - Sec Load Impedance; 260Ω
 - Insertion Loss; 4.0dB MAX @ 1KHz, 0dBm, DC 50mA
 - Frequency Response (relative to 1KHz) ±2.5dB @ 200Hz to 4KHz, 0dBm, DC 50mA
 - Longitudinal Balance; 60dB MIN @ 60Hz to 1KHz 40dB MIN @ 1KHz to 4KHz (Per FCC Part 68.310 with 4 grounded)
 - Return Loss; 8dB MIN @ 200Hz to 4KHz, 0dBm
 - DC Resistance; (1-2)= 170Ω ±10% (3-4)= 170Ω ±10%
 - Turns Ratio; (1-2):(4-3) = 1:1.00±2%
 - Dielectric Strength; 1875Vrms 1 second @ Pri to Sec
 - Total Harmonic Distortion: -60dB TYP @ 600Hz, -10dBm

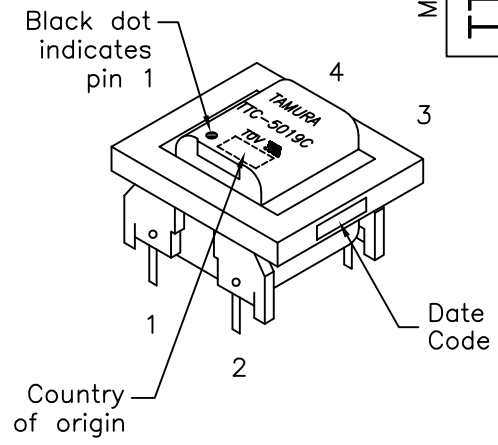

MODEL NUMBER
TTC-5019

- B. Operating Temperature: -40°C to +85°C
 C. Storage temperature; -40°C to +85°C
 D. Soldering temperature; 260°C MAX for 10 sec MAX
 E. Reliability Test; Refer to page 2
 F. Marking; TTC-5019C, TAMURA, date code and country of origin "C" designates UL approved family classification.
 G. Safety; UL1950 3rd Edition, UL60950, EN60950
 H. Schematic Diagram;

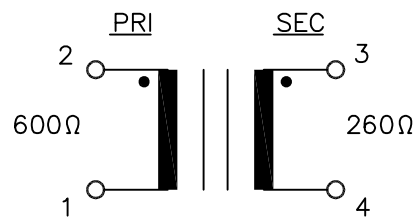

I. Mechanical Specifications;

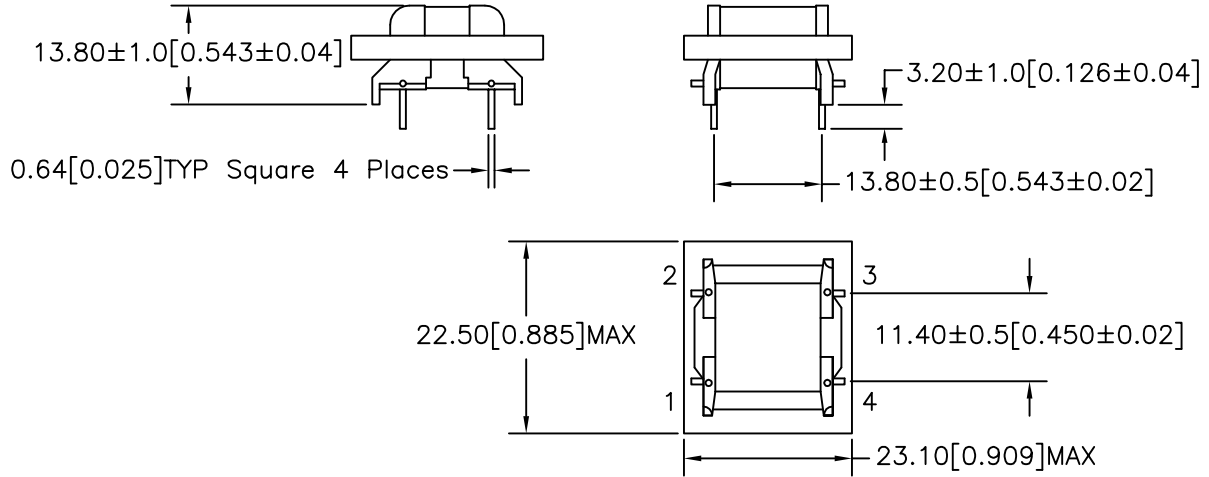

PREPARED BY:
K. BRENNAN

ENGINEER:
M. PITCHAI

QUALITY CONTROL:
T. CLEM

APPROVED:
Y. SEKIGUCHI

DRAWING CONTROL NO. P-A1-12503 ACAD\TTC\A1125031.DWG	REV D	MODEL DESCRIPTION MODEM COUPLING TRANSFORMER	MODEL SPECIFICATION TTC-5019
CONTENTS OF THIS DRAWING ARE SUBJECT TO CHANGE WITHOUT PRIOR NOTICE		TAMURA CORPORATION OF AMERICA 43352 BUSINESS PARK DRIVE, TEMECULA, CA. 92590-6624 (951) 699-1270 FAX 9516769482	DIM: mm(In) SCL: 1/1 SH: 1 OF 2

PROPRIETARY NOTICE: THIS DRAWING PRINT OR DOCUMENT AND SUBJECT MATTER DISCLOSED HEREIN ARE PROPRIETARY ITEMS TO WHICH TAMURA RETAINS THE EXCLUSIVE RIGHT OF DISSEMINATION, REPRODUCTION, MANUFACTURE AND SALE. THIS DRAWING, PRINT OR DOCUMENT IS SUBMITTED IN CONFIDENCE FOR CONSIDERATION BY THE RECIPIENT ALONE UNLESS PERMISSION FOR FURTHER DISCLOSURE IS EXPRESSLY GRANTED IN WRITING.

REV. Status

E. Reliability Test;

REVISION
DATE/ENGREVISION A
ADDED
A.11-A.13.
03/20/02 MPREVISION B
ADDED
PAGE 2
RELIABILITY TEST
04/23/02 MPREVISION C
ADDED
BABT & TUV
TO MARKING
05/09/02 MPREVISION D
DELETED BABT
05/07/05 MP

No.	Item	Condition	Specifications
1	Solderability	Temperature: $230^{\circ} \pm 5^{\circ}\text{C}$ Solder time: 3 ± 0.5 seconds Solder: H60A or H63A Flux: 75% Methanol and 25% Rosin	After that the sample shall be covered by solder uniformly at more than 90% of circumference.
2	Resistance to Soldering heat	Temperature: $260^{\circ} \pm 5^{\circ}\text{C}$ Solder time: 10 ± 1 seconds Solder: H60A or H63A Flux: 75% Methanol and 25% Rosin	Sample shall not show any unusual appearance.
3	Resistance to soldering heat (hand soldering)	Temperature: $350^{\circ} \pm 10^{\circ}\text{C}$ Solder time: 3 ± 1 seconds	Sample shall not show any unusual appearance.
4	Thermal cycle test	JIS C 0025 10 cycles Temperature -10°C 30 min 25°C 5 min 70°C 30 min	After that sample shall be replaced in normal ambient for 60 min., it shall not show any unusual appearance and should meet the requirement of dielectric strength and insulation resistance no less than $10\text{M}\ddot{\text{U}}$
5	Heat test	JIS C 0021 Temperature: 85°C Time: 96 hours	After that sample shall be replaced in normal ambient for 60 min., it shall not show any unusual appearance and should meet the requirement of dielectric strength and insulation resistance no less than $10\text{M}\ddot{\text{U}}$
6	Cold test	JIS C 0020 Temperature: -25°C Time: 96 hours	After that sample shall be replaced in normal ambient for 60 min., it shall not show any unusual appearance and should meet the requirement of dielectric strength and insulation resistance no less than $10\text{M}\ddot{\text{U}}$
7	Humidity Test	JIS C 0022 Temperature: 40°C Humidity: 90~95% Time: 96 hours	After that sample shall be replaced in normal ambient for 60 min., it shall not show any unusual appearance and should meet the requirement of dielectric strength and insulation resistance no less than $10\text{M}\ddot{\text{U}}$
8	Vibration test	JIS C 0040 Frequency: 10~55Hz Amplitude (total excursion) 1.5mm Transverse time: 5 min. Direction Time: XYZ each 50 min.	After that sample shall be replaced in normal ambient for 60 min., it shall not show any unusual appearance and should meet the requirement of dielectric strength and insulation resistance no less than $10\text{M}\ddot{\text{U}}$
9	Terminal strength	JIS C 0051.2.5 5N 10 seconds	No breakage of magnet wire, etc.

PREPARED BY:
K. BRENNANENGINEER:
M. PITCHAIQUALITY CONTROL:
T. CLEMAPPROVED:
Y. SEKIGUCHIDWG CONTROL NO.
P-A1-12503
ACAD\TTC\A1125032.DWGREV
DMODEM COUPLING
TRANSFORMER

TTC-5019

MODEL SPECIFICATION

CONTENTS OF THIS DRAWING ARE
SUBJECT TO CHANGE WITHOUT
PRIOR NOTICE**TAMURA CORPORATION OF AMERICA**
43352 BUSINESS PARK DRIVE, TEMECULA, CA. 92590-6624
(951) 699-1270 FAX 9516769482

DIM: N/A | SCL: N/A | SH: 2 OF 2

PROPRIETARY NOTICE: THIS DRAWING PRINT OR DOCUMENT AND SUBJECT MATTER DISCLOSED HEREIN ARE PROPRIETARY ITEMS TO WHICH TAMURA RETAINS THE EXCLUSIVE RIGHT OF DISSEMINATION, REPRODUCTION, MANUFACTURE AND SALE. THIS DRAWING, PRINT OR DOCUMENT IS SUBMITTED IN CONFIDENCE FOR CONSIDERATION BY THE RECIPIENT ALONE UNLESS PERMISSION FOR FURTHER DISCLOSURE IS EXPRESSLY GRANTED IN WRITING.