

ALL DIMENSIONS ARE  
FOR REFERENCE ONLY

DIMENSIONS ARE IN INCHES [MILLIMETERS]  
UNLESS OTHERWISE NOTED

PRODUCT SPECIFICATION SHEET			DWG NO.	396 SP	
REVISIONS			TITLE		
REV	ECO	DESCRIPTION		BY/DATE	APPROVED
A		INITIAL RELEASE		IB 6 JUN 96	

SPECIFICATIONS

OVERALL HEIGHT ..... 7 5/16 [185.75]

SHIPPING WEIGHT ..... 3 POUNDS [1.3 KG]

VICE OPENING

WITH JAW PADS ..... 6 [152] MAXIMUM  
..... 0 [0] MINIMUM

W/O JAW PADS ..... 6 1/4 [158.75] MAXIMUM  
..... 1/8 [3.175] MINIMUM

MATERIAL:

- 366 VICE HEAD .... SEE 366-SP SHEET FOR SPECIFICATIONS
- 300 BASE ..... SEE 300-SP SHEET FOR SPECIFICATIONS

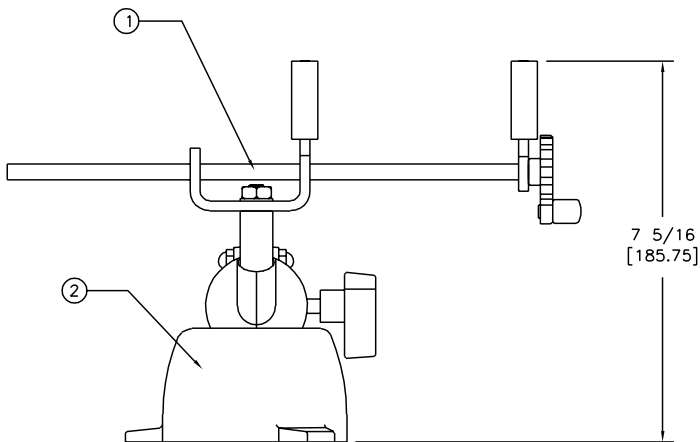

ALL DESIGN, OPERATIVE, AND PROCESS DATA PERTAINING TO THE ARTICLE ON THIS SHEET IS THE PROPERTY OF PANAVISE PRODUCTS, INC., RENO, NV. THIS INFORMATION IS DISCLOSED IN CONFIDENCE AND IS NOT TO BE COPIED, REPRODUCED, OR REVEALED TO OR APPROPRIATED BY OTHERS, IN PART OR IN WHOLE, WITHOUT THE EXPRESSED CONSENT OF PANAVISE. THIS PRINT IS LOANED, AND MUST NOT BE USED IN ANY MANNER DETRIMENTAL TO THE INTEREST OF PANAVISE, AND MUST BE RETURNED ON DEMAND



**PANAVISE®**  
7540 Colbert Drive, Reno, Nevada 89511-1225  
Phone (702) 850-2900, Fax (702) 850-2929

TITLE  
WIDE OPENING  
HEAD PANAVISE

BASIC DIM. ENGLISH [ALTERNATE DIM. METRIC]

DRAWN	DATE	SCALE	SIZE	DWG. NO.	REV
I BENNETT	6 JUN 96	NONE	SHT 1 OF 1	A 396 SP	A