

ALL DIMENSIONS ARE  
FOR REFERENCE ONLY

DIMENSIONS ARE IN INCHES [MILLIMETERS]  
UNLESS OTHERWISE NOTED

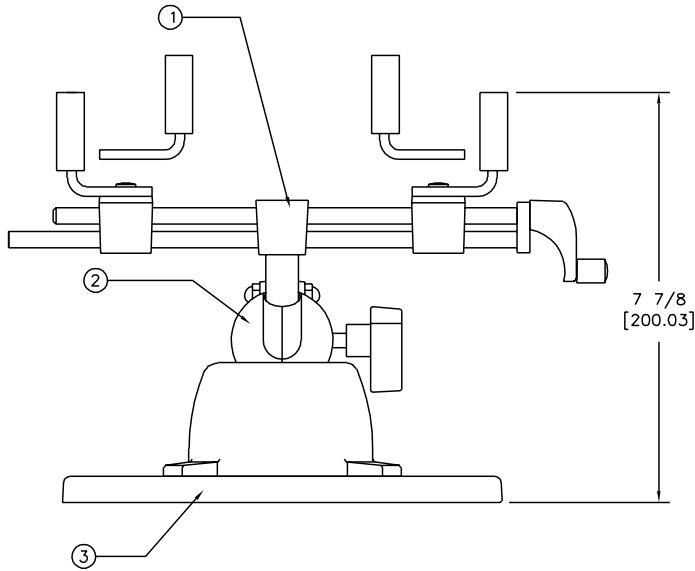

PRODUCT SPECIFICATION SHEET			DWG NO.	350-SP	
REVISIONS			TITLE		
REV	ECO	DESCRIPTION		BY/DATE	APPROVED
A		INITIAL RELEASE		IB 6 JUN 96	

### SPECIFICATIONS

OVERALL HEIGHT ..... 7 7/8 [200.03]

SHIPPING WEIGHT ..... 5 POUNDS [2.3 KG]

VICE OPENING

JAWS OUT ..... 9 1/4 [234.95] MAXIMUM  
 ..... 3 3/4 [95.25] MINIMUM  
 JAWS IN ..... 5 [127.0] MAXIMUM  
 ..... 0 [0] MINIMUM

MATERIAL:

1. 376 HEAD ..... SEE 376 SP SHEET FOR SPECIFICATIONS
2. 300 BASE ..... SEE 300-SP SHEET FOR SPECIFICATIONS
3. 312 PARTS TRAY ..... SEE 312-SP SHEET FOR SPECIFICATIONS

ALL DESIGN, OPERATIVE, AND PROCESS DATA PERTAINING TO THE ARTICLE ON THIS SHEET IS THE PROPERTY OF PANAVISE PRODUCTS, INC., RENO, NV. THIS INFORMATION IS DISCLOSED IN CONFIDENCE AND IS NOT TO BE COPIED, REPRODUCED, OR REVEALED TO OR APPROPRIATED BY OTHERS, IN PART OR IN WHOLE, WITHOUT THE EXPRESSED CONSENT OF PANAVISE. THIS PRINT IS LOANED, AND MUST NOT BE USED IN ANY MANNER DETRIMENTAL TO THE INTEREST OF PANAVISE, AND MUST BE RETURNED ON DEMAND



**PANAVISE®**

7540 Colbert Drive, Reno, Nevada 89511-1225  
Phone (702) 850-2900, Fax (702) 850-2929

TITLE

MULTI-PURPOSE  
WORK CENTER

BASIC DIM. ENGLISH [ALTERNATE DIM. METRIC]

DRAWN	DATE	SCALE	SIZE	DWG. NO.	REV
I BENNETT	6 JUN 96	NONE	SHT 1 OF 1	A 350-SP	A