

LOC	DIST	REVISIONS 変更					
J	—	P	LTR	DESCRIPTION	DATE	DWN	APVD
		0		RELEASED FJ00-1407-02	9 JUL'02	J.S	S.S

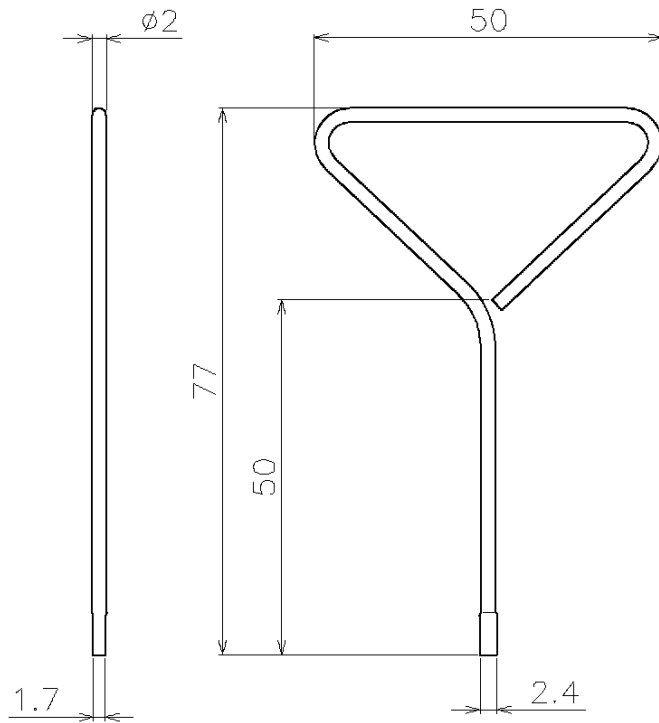

NOTES)

1. はじめに (Introduction)

本工具はダイナミック2000シリーズコネクタのタブコンタクトを取外す為の  
カッティング治具です。

This is a cutting tool designed to cut a TAB contact from Dynamic  
2000 series connectors.

2. 適用製品 (Applicable products)

Dynamic 2000 series Header type connectors  
(P/N:1318123-1; 1318124-1 etc.)

3. 外形寸法 (Overall dimensions)

50(W)×2(D)×77(H) mm

4. 重量 (Weight)

約 20 g (20 g Approx.)

5. 取扱説明書 (Instruction sheet)

411-78047

RELEASED FOR PUBLICATION

ALL RIGHTS RESERVED.

THIS DRAWING IS UNPUBLISHED.

© COPYRIGHT BY TYCO ELECTRONICS CORPORATION.

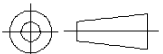
DIMENSIONS: 単位: 特 MM	DWN	J.SEKI	27JUN2002	MATERIAL 材料	—	FINISH 仕上	—
	CHK	S.SUZUKI	9 JUL2002	 Tyco Electronics AMP K.K. Kawasaki, Japan			
TOLERANCES UNLESS OTHERWISE SPECIFIED: 一般公差	APVD	H.TANAKA	9 JUL2002				
	PRODUCT SPEC 製品規格	—		NAME 名称	ダイナミック2000シリーズタブ用カッティング工具 TAB CUTTING TOOL for D-2000		
	APPLICATION SPEC 取付適用規格	—		SIZE	A4	CAGE CODE	00779
	WEIGHT	—		DRAWING NO 番号	C-919041-2		RESTRICTED TO
0 PLC ± -							
1 PLC ± -							
2 PLC ± -							
3 PLC ± -							
4 PLC ± -							
ANGLES ± -							
		CUSTOMER DRAWING		SCALE 尺度	1:1	SHEET	1 OF 1
				REV	0		