

Instruction Manual

Variable Speed

Cordless

Drill & Driver

Model: EY6225

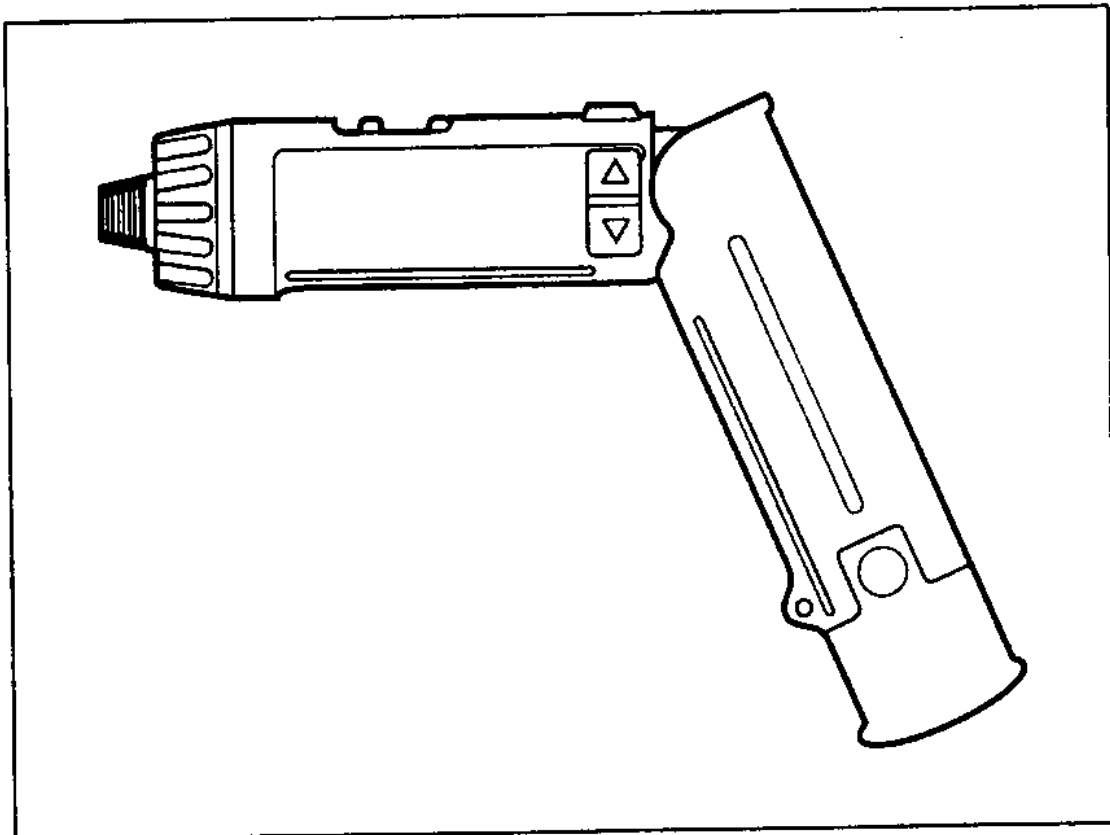

Panasonic ®

⚠ IMPORTANT

This manual contains safety information. Read manual completely before first using this product.

SAVE THESE INSTRUCTIONS

GENERAL SAFETY RULES-FOR ALL BATTERY OPER- ATED TOOLS

WARNING!

READ AND UNDERSTAND ALL INSTRUCTIONS.

- Failure to follow all instructions listed below, may result in electric shock, fire and/or serious personal injury.

SAVE THESE INSTRUCTIONS

Work Area

- 1) **Keep your work area clean and well lit.**
Cluttered benches and dark areas invite accidents.
- 2) **Do not operate power tools in explosive atmospheres, such as in the presence of flammable liquids, gases, or dust.**
Power tools create sparks which may ignite the dust or fumes.
- 3) **Keep bystanders, children, and visitors away while operating a power tool.**
Distractions can cause you to lose control. Make sure that no one is beneath, or on the other side of the area when you are working.

Electrical Safety

- 4) **A battery operated tool with integral batteries or a separate battery pack must be recharged only with the specified charger for the battery.**
A charger that may be suitable for one type of battery may create a risk of fire when used with another battery.
- 5) **Use battery operated tool only with specifically designated battery pack.**
Use of any other batteries may create a risk of fire.

Personal Safety

- 6) **Stay alert, watch what you are doing, and use common sense when operating a power tool. Do not use tool while tired or under the influence of drugs, alcohol, or medication.**
A moment of inattention while operating power tools may result in serious personal injury.
- 7) **Dress properly. Do not wear loose clothing or jewelry. Contain long hair.**
Keep your hair, clothing, and gloves away from moving parts.
Loose clothes, jewelry, or long hair can be caught in moving parts.
- 8) **Avoid accidental starting. Be sure switch is in the locked or off position before inserting battery pack.**
Carrying tools with your finger on the switch or inserting the battery pack into a tool with the switch on invites accidents.
- 9) **Remove adjusting keys or wrenches before turning the tool on.**
A wrench or a key that is left attached to a rotating part of the tool may result in personal injury.
- 10) **Do not overreach. Keep proper footing and balance at all times.**
Proper footing and balance enable better control of the tool in unexpected situations.
- 11) **Use safety equipment. Always wear eye protection.**
Dust mask, non-skid safety shoes, hard hat, or hearing protection must be used for appropriate conditions.

Tool use and care

- 12) **Use clamps or other practical way to secure and support the work-piece to a stable platform.**
Holding the work by hand or against your body is unstable and may lead to loss of control.

- 13) **Do not force tool. Use the correct tool for your application.**
The correct tool will do the job better and safer at the rate for which it is designed.
- 14) **Do not use tool if switch does not turn it on or off.**
A tool that cannot be controlled with the switch is dangerous and must be repaired.
- 15) **Disconnect battery pack from tool or place the switch in the locked or off position before making any adjustments, changing accessories, or storing the tool.**
Such preventive safety measures reduce the risk of starting the tool accidentally.
- 16) **Store idle tools out of reach of children and other untrained persons.**
Tools are dangerous in the hands of untrained users.
- 17) **When battery pack is not in use, keep it away from other metal objects like: paper clips, coins, keys, nails, screws, or other small metal objects that can make a connection from one terminal to another.**
Shorting the battery terminals together may cause sparks, burns or a fire.
- 18) **Maintain tools with care. Keep cutting tools sharp and clean.**
Properly maintained tools with sharp cutting edge are less likely to bind and are easier to control.
- 19) **Check for misalignment or binding of moving parts, breakage of parts, and any other condition that may affect the tool's operations. If damaged, have the tool serviced before using.**
Many accidents are caused by poorly maintained tools.
- 20) **Use only accessories that are recommended by the manufacturer for your model.**
Accessories that may be suitable for one tool may create a risk of injury when used on another tool.

Service

- 21) **Tool service must be performed only by qualified repair personnel.**
Service or maintenance performed by unqualified personnel may result in a risk of injury.
- 22) **When servicing a tool, use only identical replacement parts. Follow instructions in the Maintenance section of this manual.**
Use of unauthorized parts or failure to follow Maintenance Instructions may create a risk of shock or injury.

SPECIFIC SAFETY RULES

- 1) **Hold tool by insulated gripping surfaces when performing an operation where the cutting tool may contact hidden wiring.**
Contact with a "live" wire will also make exposed metal parts of the tool "live" and shock the operator.

Symbol	meaning
v	Volts
— — —	Direct Current
n_0	no load speed
.../min	revolution or reciprocation per minutes
	Rotation only

FOR BATTERY CHARGER & BATTERY PACK

1) **SAVE THESE INSTRUCTIONS**

-This manual contains important safety and operating instructions for battery charger EY0225.

2) Before using battery charger, read all instructions and cautionary markings on (1) battery charger, (2) battery pack.

3) **CAUTION** -To reduce the risk of injury, charge only Battery Pack EY9021, EY9025. Other types of batteries may burst causing personal injury and damage.

4) Do not expose charger to rain or snow.

5) To reduce risk of damaging the electric plug and cord, pull by plug rather than cord when disconnecting charger.

6) Make sure cord is located so that it will not be stepped on, tripped over, or otherwise subjected to damage or stress.

7) An extension cord should not be used unless absolutely necessary. Use of improper extension cord could result in a risk of fire and electric shock. If extension cord must be used, make sure:

- that pins on plug of extension cord are the same number, size and shape as those of plug on charger.
- that extension cord is properly wired and in good electrical condition.
- that wire size is large enough for ampere rating of charger as specified below.

RECOMMENDED MINIMUM AWG SIZE OF EXTENSION CORDS FOR BATTERY CHARGERS				
AC Input Rating, Amperes		AWG Size of Cord		
Equal to or greater than	But less than	Length of Cord, Feet		
		25	50	100 150
0	2	18	18	18 16

8) Do not operate charger with damaged cord or plug—replace them immediately.

9) Do not operate charger if it has received a sharp blow, been dropped, or otherwise damaged in any way; take it to a qualified serviceman.

10) Do not disassemble charger; take it to a qualified serviceman when service or repair is required. Incorrect reassembly may result in a risk of electric shock or fire.

11) To reduce the risk of electric shock, unplug charger from outlet before attempting any maintenance or cleaning.

12) The charger and battery pack are specifically designed to work together. Do not attempt to charge any other cordless tool or battery pack with this charger.

13) Do not attempt to charge the battery pack with any other charger.

14) Do not attempt to disassemble the battery pack housing.

15) Do not store the tool and battery pack in locations where the temperature may reach or exceed 122°F (50°C) (such a metal tool shed, or a car in the summer), which can lead to deterioration of the storage battery.

16) Do not charge battery pack when the temperature is BELOW 32°F (0°C) or ABOVE 104°F (40°C). This is very important.

17) Do not incinerate the battery pack. It can explode in a fire.

- 18) Avoid dangerous environment. Do not use charger in damp or wet locations.
- 19) The charger is designed to operate on standard household electrical power only. Do not attempt to use it on any other voltage!
- 20) Do not abuse cord. Never carry charger by cord or yank it to disconnect from outlet. Keep cord away from heat, oil and sharp edges.
- 21) Charge the battery pack in a well ventilated place, do not cover the charger and battery pack with a cloth, etc., while charging.
- 22) Use of an attachment not recommended may result in a risk of fire, electric shock, or injury to persons.
- 23) Do not short the battery pack. A battery short can cause a large current flow, over heating and burns.
- 24) NOTE: If the supply cord of this appliance is damaged, it must only be replaced by a repair shop appointed by the manufacturer, because special purpose tools are required.
- 25) TO REDUCE THE RISK OF ELECTRIC SHOCK, THIS APPLIANCE HAS A POLARIZED PLUG (ONE BLADE IS WIDER THAN THE OTHER).
This plug will fit in a polarized outlet only one way. If the plug does not fit fully in the outlet, reverse the plug. If it still does not fit, contact a qualified electrician to install the proper outlet. Do not change the plug in any way.

IMPORTANT NOTICE

PLEASE READ THIS ENTIRE NOTICE BEFORE OPERATING YOUR NEW PANASONIC CORDLESS POWER TOOL!

PANASONIC'S CHARGING SYSTEM UTILIZES A QUALITY HIGH TEMPERATURE NICKEL CADMIUM BATTERY PACK IN CONJUNCTION WITH OUR SELF-DIAGNOSTIC UNIVERSAL INVERTER CHARGER.

THIS HIGH TEMPERATURE NICKEL CADMIUM BATTERY PACK REQUIRES A "BREAK-IN PERIOD" TO REACH MAXIMUM OPERATING CAPACITY. THE "BREAK-IN PERIOD" IS ACCOMPLISHED DURING NORMAL USAGE DURING THE FIRST 6-8 CHARGE AND DISCHARGE CYCLES OF THE BATTERY PACK.

AFTER THE "BREAK-IN PERIOD" IS COMPLETED, THE BATTERY PACK WILL MAINTAIN MAXIMUM OPERATING CAPACITY THROUGHOUT THE NORMAL LIFE OF THE BATTERY PACK.

Parts and Controls

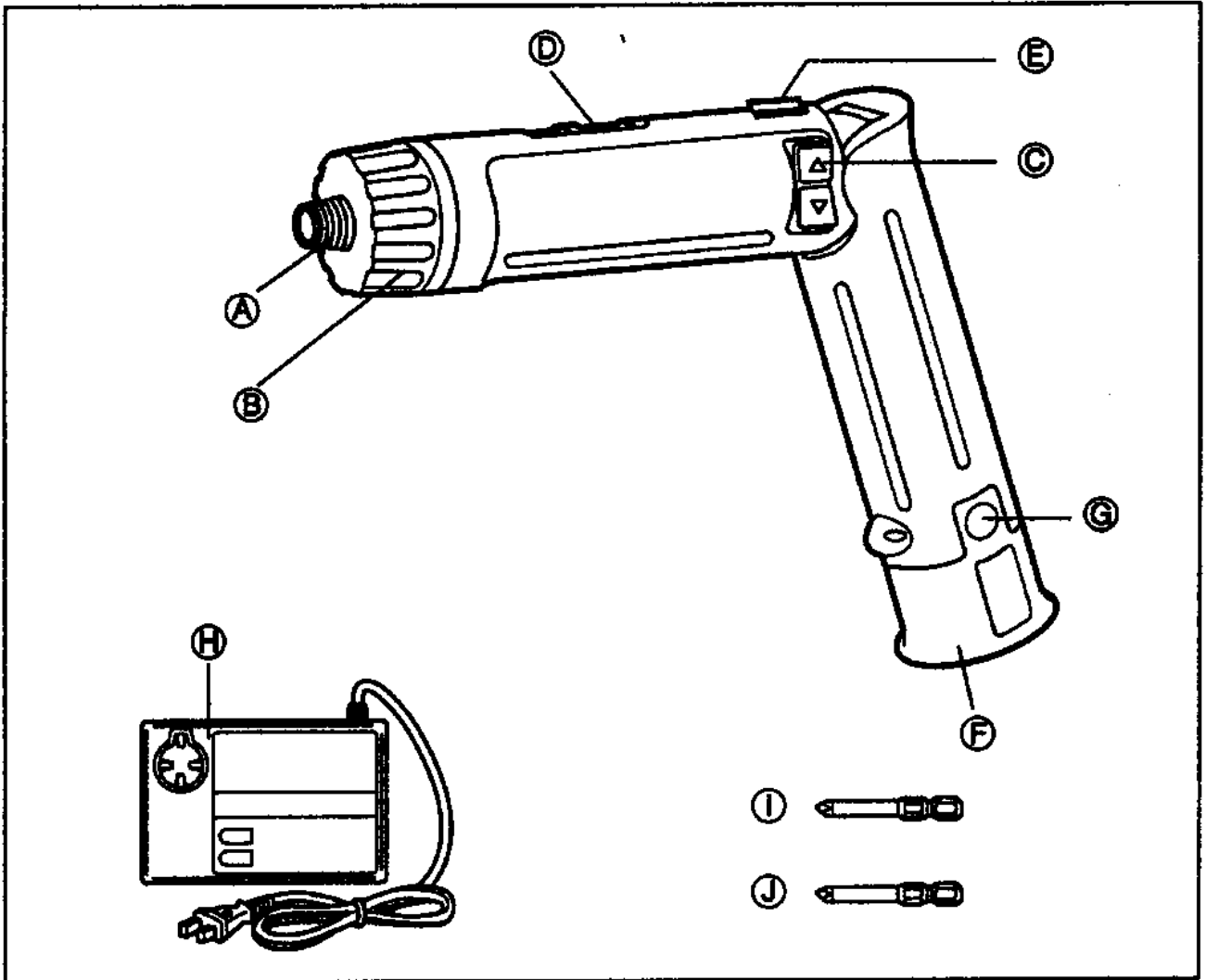

(A)	Hexagonal bit holder	(F)	Battery pack (EY9025)
(B)	Clutch handle	(G)	Battery pack release button
(C)	Main switch	(H)	Battery charger (EY0225)
(D)	Speed selector switch	(I)	#2 Philips bit (50mm)
(E)	Main switch lock	(J)	#1 Philips bit (50mm)

Operation

A Hexagonal bit holder

1. Attaching the bits

NOTE: When attaching or removing bit, be sure to set the main switch lock at the lock position.

1. Hold the bit holder and pull it against the driver.
2. Insert the bit into the hole of the drive shaft.
3. The bit holder will return to its original position when released.
4. Pull the bit to make sure it does not come out.
5. To remove the bit, pull back on the bit holder in the same way.

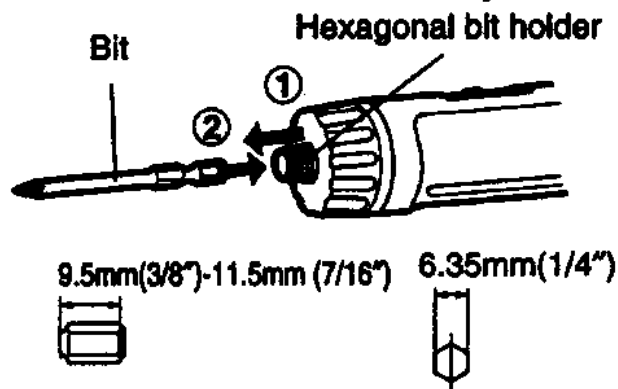

B Clutch handle (Clutch Torque Setting)

Adjust the torque to one of the 21 possible settings to the job. There is an interval of about 0.13 Nm (1.3kgf-cm or 1.1 in-lbs) between steps.

CAUTION! Test the setting before actual operation.



Reference for Adjusting Torque

Scale	Torque	Use
1	Approx: 0.29 Nm (3.0 kgf-cm or 2.6 in-lbs)	For driving screws
5	Approx: 0.82 Nm (8.4 kgf-cm or 7.3 in-lbs)	
9	Approx: 1.35 Nm (13.8 kgf-cm or 12.0 in-lbs)	
13	Approx: 1.88 Nm (19.2 kgf-cm or 16.6 in-lbs)	
17	Approx: 2.41 Nm (24.6 kgf-cm or 21.3 in-lbs)	
21	Approx: 2.94 Nm (30.0 kgf-cm or 26.0 in-lbs)	
	Approx: 4.4 Nm (45.0 kgf-cm or 39.0 in-lbs)	For powerful driving screws and drilling

- When use at high speeds, set the scale at 10 or below. (Operation stops at the maximum torque 1.5Nm (15kgf-cm), when the scale is higher.)
- The auto shut off function may become inoperable at use at higher scales when battery power drops. Recharge the battery in that case.

NOTE: The chart is only a reference. The torque setting may differ by materials, types of screws, etc. Please test it at your own conditions before use.

Bit locking function

With the switch at off, the bit is locked in place, and the tool can be used as a manual screw-driver - up to 14.7Nm (150kgf-cm, 130 in-lbs). There will be a little play in the driving shaft, but this is not a malfunction.

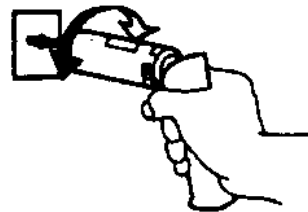

C Main switch (ON/OFF)

Push the upper half of the switch for forward rotation, or the lower half for reverse rotation.

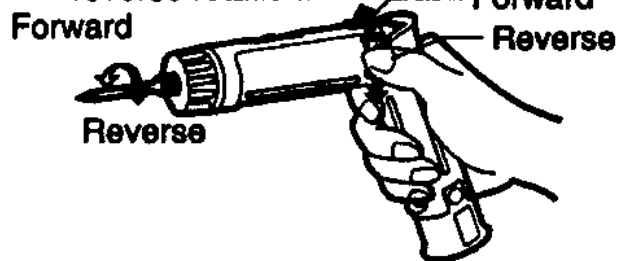

D Speed selector switch

To suit the application of this tool, two different rotational speeds are available. Depending upon use, either the high or low speed should be selected.

LOW	200/min (RPM)	strong torque
HIGH	600/min (RPM)	less torque

CAUTION: Check rotational speed selection before operating this tool.

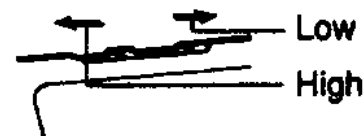

Ⓔ **Main switch lock**

After use, set the main switch lock at the lock position to prevent accidental operation.

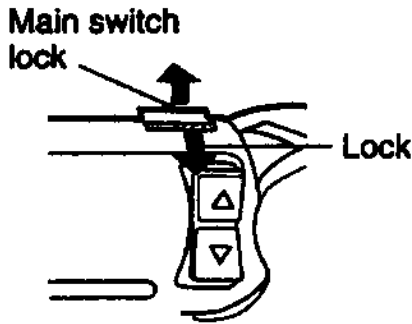

Ⓕ **Battery pack (EY9025)**

CAUTION

When you charge the battery pack for the first time, or after prolonged storage, charge it for about 24 hours to bring the battery up to full capacity.

1. Press the battery pack release buttons Ⓒ on both sides and pull the pack away from the tool.
2. Charge the battery pack using the battery charger.
3. After the charging has been completed, remove the battery pack from the charger and connect it to the tool. Disconnect the charger from the power source when not in use.

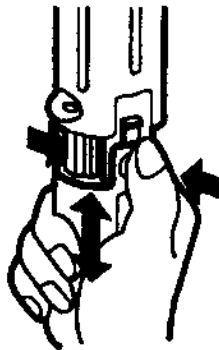

Battery Pack Life

The rechargeable batteries have a limited life. If the operation time becomes extremely short after recharging, replace the battery with a new one. If the tool is not frequently used, charge the battery pack at least once every six months to maintain battery performance.

Note: Use under extremely hot or cold conditions will reduce operation capacity per charge.

Ⓖ **Battery pack release button**

Ⓗ **Battery charger (EY0225)**

1. Plug the charger into an AC outlet.
2. Insert the battery pack firmly into the charger.

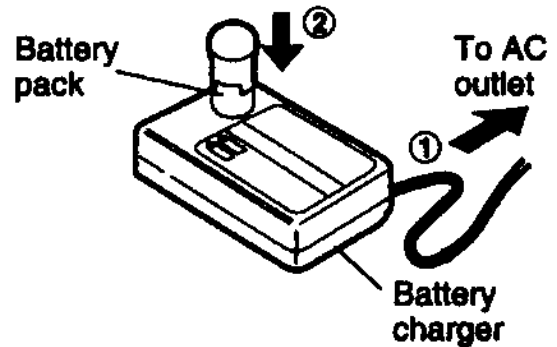

3. During charging, the charging lamp will be lit.

When charging is completed, an internal electronic switch will automatically be triggered to prevent overcharging.

- Charging will not start if the battery pack is warm (for example, immediately after heavy-duty operation). The orange standby lamp will be lit until the battery cools down. Charging will then begin automatically.
4. When charging is completed, the charging lamp will start flashing rapidly.
 5. If a fully charged battery pack is inserted into the charger again, the charging lamp may light up and then flash slowly. After several minutes, the charging lamp may flash quickly to indicate the charging is completed.
 6. If the charging lamp does not light immediately after the charger is plugged in, or if after the standard charging time the lamp does not go off, consult an authorized dealer.

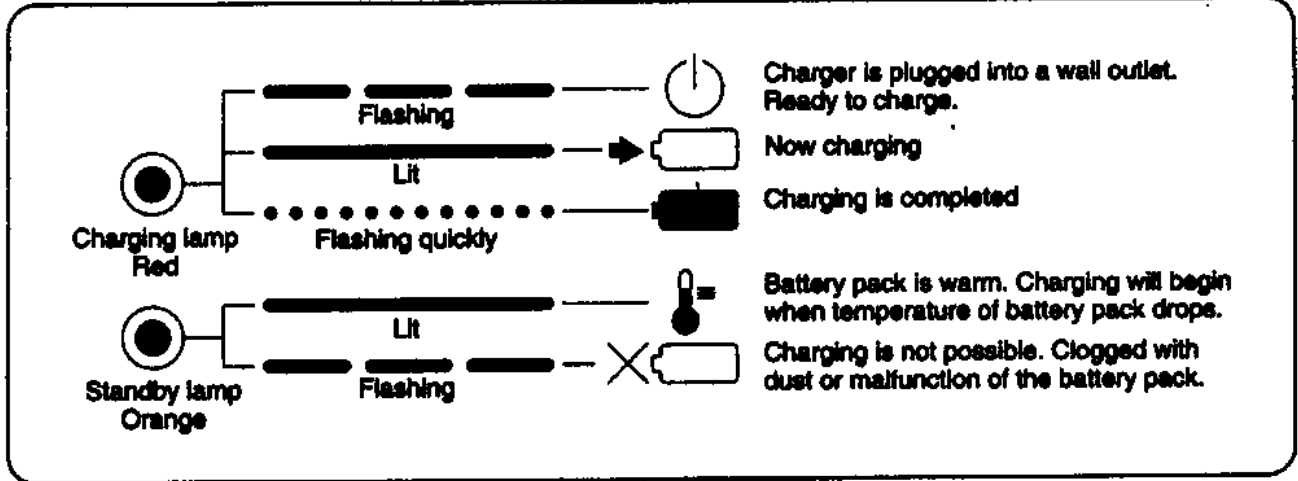

① #2 Phillips bit (50mm)

② #1 Phillips bit (50mm)

Maintenance

Use only a dry, soft cloth for wiping the unit. Do not use a damp cloth, thinner, benzene, or other volatile solvents for cleaning.

ATTENTION:

The nickel cadmium battery you have purchased is recyclable. At the end of its useful life, under various state and local laws, it is illegal to dispose of this battery into your municipal waste stream. Please call 1-800-8-BATTERY for information on how to recycle this battery.



Specifications

Cordless Drill & Driver (EY6225)

Capacity	Driving	Machine screw	M2.5-M5
		Wood screw	ϕ 3.1 x 13mm (1/8" x 33/64") ϕ 3.8 x 25mm (5/32" x 63/64")
	Drilling	For metal	ϕ 2mm (5/64")
Motor		DC Motor 3.6V	
No load speed		LOW: 200/min (rpm.) HIGH: 600/min (rpm.)	
Maximum torque		LOW: 4.4Nm (45kgf-cm, 39in-lbs) HIGH: 1.5Nm (15kgf-cm, 13in-lbs)	
Maximum clutch torque		3.0Nm (30kgf-cm, 26in-lbs) at position 21	
Overall length		298mm (11-21/32")	
Weight (with battery pack)		0.5kg, (1.1lbs)	

Battery Pack (EY9025)

Storage Battery	Ni-Cd Battery
Battery voltage	3.6V DC (1.2V x 3cells)

Battery Charger (EY0225)

Weight	0.5kg, (1.1 lbs)		
Charging time	Applicable Battery Pack		Standard charging time
	2.4V	3.6V	
	EY9021	EY9025	Approx: 15 minutes

**30-DAY QUALITY
SATISFACTION GUARANTEE:**

If you are dissatisfied with any Panasonic Cordless Power Tool for any reason, simply return it to the place of purchase with a dated proof of purchase, in the original packaging, with all accessories, parts and instructions, within 30 days of the date of purchase, for a full refund, or call Panasonic at 201-392-6655. Abuse or misapplication of any power tool voids the guarantee.

PANASONIC HOME & COMMERCIAL PRODUCTS COMPANY

One Panasonic Way, Secaucus, New Jersey 07094