

CUSTOMER HOTLINE 1 800 722-1111

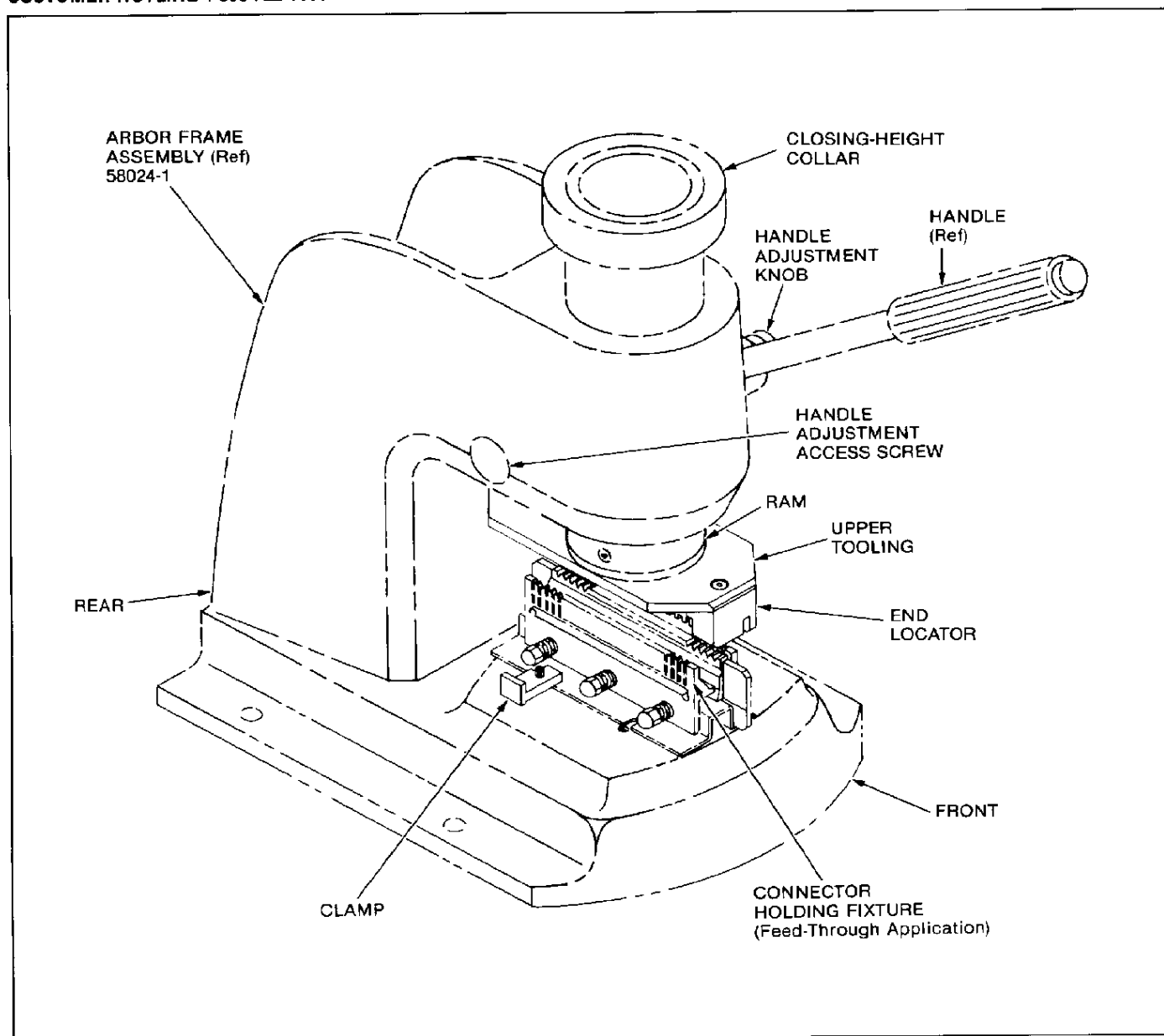

Fig. 1

1. INTRODUCTION

This instruction sheet (IS) covers the use of the AMP MTA Tooling Assembly 58040-1 which is used for installing discrete wires or ribbon cable into MTA 100 receptacle, posted, and card-edge connectors with contacts on .156-in. centerlines.

Read these instructions thoroughly before using the tool assembly.

NOTE All dimensions on this instruction sheet are in inches.

2. DESCRIPTION (Figure 1)

The tooling assembly consists of an upper tooling assembly with four socket head capscrews which attach the upper tool to the ram, and two clamps and hardware for attaching a connector holding fixture to the arbor frame assembly.

NOTE The connector holding fixtures are available with cutoff features for end-of-line applications and without cutoff features for feed-through applications.

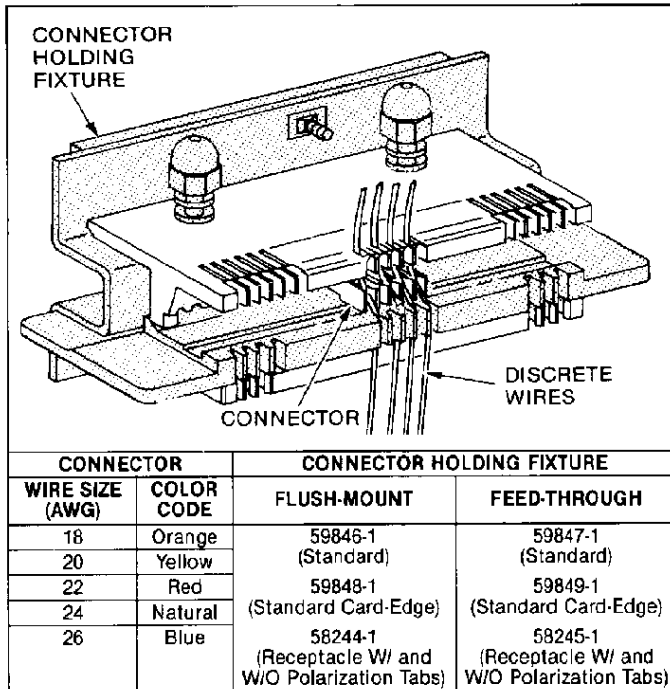

Fig. 2

3. CABLE REQUIREMENTS

The tooling assembly will terminate ribbon cable and discrete wires from 26 AWG to 18 AWG, as shown in Figure 2. Refer to Figure 3 for the recommended cable dimensions.

NOTE For procedures concerning cable requirements, setup, and cable notching, see AMP Instruction Sheet IS 6521, which is packaged with AMP Ribbon Cable Notching Tool 59835-1.

CAUTION The cable end must be cut 90° to the edge of the cable; otherwise, an improper termination will result. We suggest you use a guillotine-type cable cutter, such as the Carpenter Model 95 which can be purchased from:

Carpenter Manufacturing Co., Inc
Fairgrounds Drive
Manlius, NY 13207

4. SETUP PROCEDURE

The tooling assembly is designed to be used in the AMP Arbor Frame Assembly 58024-1. The tooling assembly can be oriented to feed wire from the front or from one side of the frame. Turning the tooling assembly to the front would accommodate end-of-line applications, and turning the assembly to the side would accommodate feed-through applications.

NOTE Connectors can be terminated with a minimum spacing between centers of connectors of 1/2 in.

1. Position upper tooling on ram and secure with four capscrews.

NOTE When making end-of-line applications, the tooling assembly can be mounted for front or side cable feed.

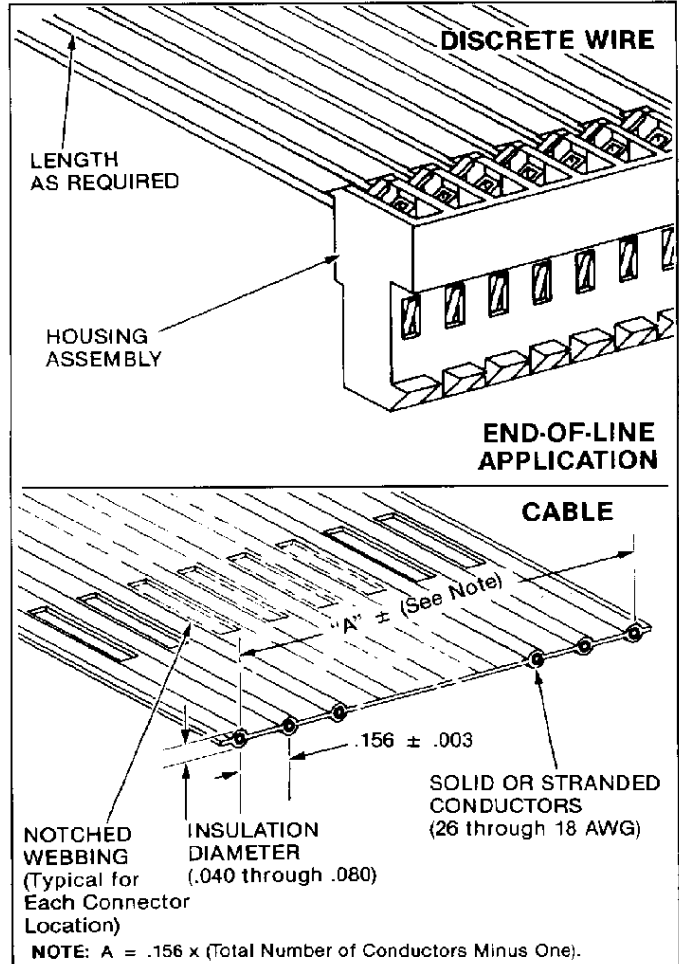

Fig. 3

2. Position connector holding fixture on base of frame assembly, and visually align the holding fixture with the upper tooling.
3. Start, but do not tighten, the screws and nuts of the clamps.

NOTE Proper orientation of the clamps depends on the size of the connector holding fixture. The clamps can be installed into either hole on each side of the holding fixture.

4. While guiding the connector holding fixture into position under the upper tooling, bottom the ram. Make sure the locating ends of the upper tooling align with the guide post on the front comb of the holding fixture.
5. With the upper tooling bottomed in the connector holding fixture, secure the clamps with the screws and nuts.
6. Adjust the closing-height collar. Loosen the hex nut in the collar and, with upper tooling fully bottomed on the connector holding fixture, turn the collar one-half turn clockwise. This will raise the upper tooling. Tighten the hex nut.
7. Raise the ram, place the appropriate connector into the connector holding fixture, insert the

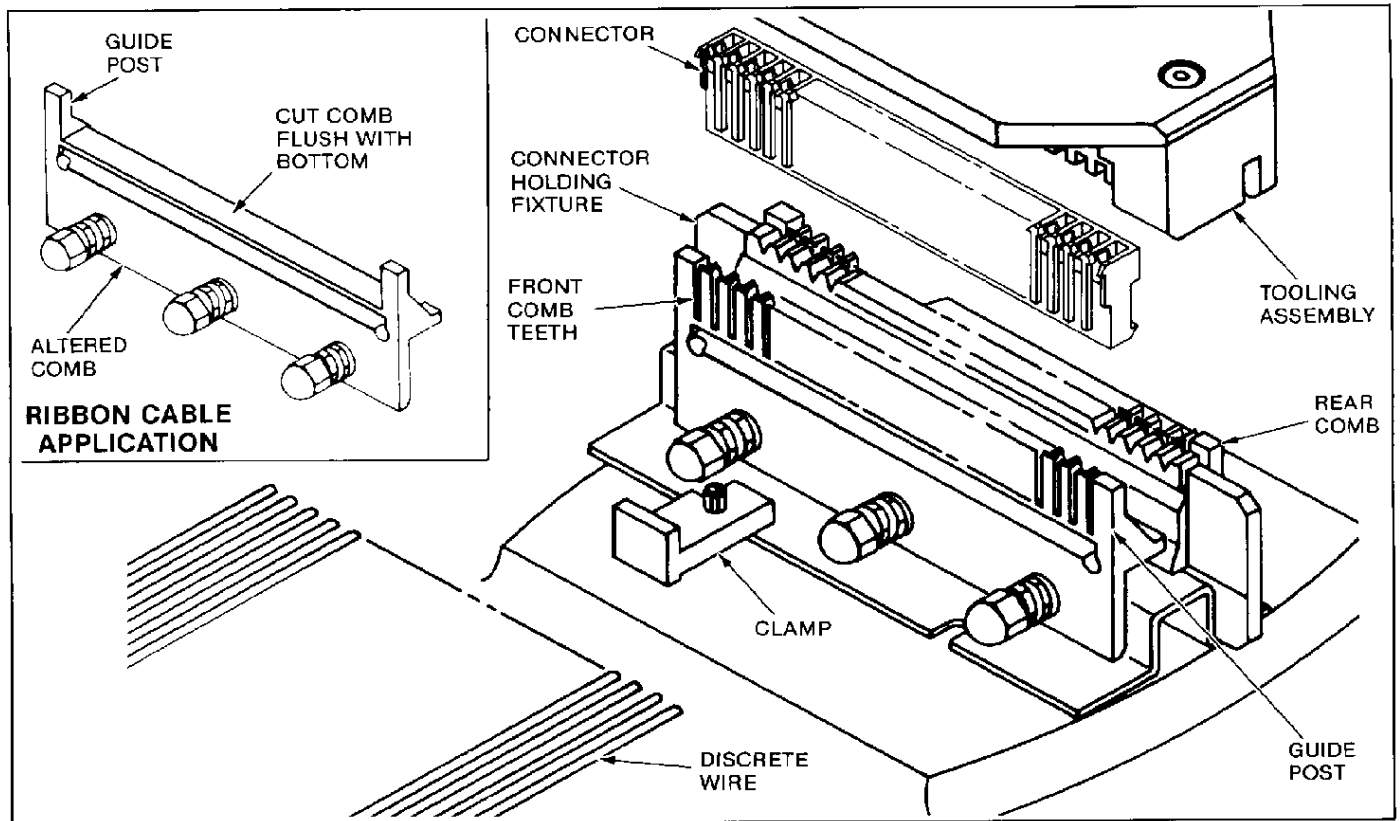

Fig. 4

proper size conductor over a connector contact, and bottom the upper tooling in the connector holding fixture.

8. Raise the ram, remove the terminated connector from the holding fixture, and inspect the termination according to Paragraph 6, INSPECTION.

9. If the wire (or cable) is inserted:

- a. TOO DEEP — loosen the hex nut in the closing-height collar, rotate the collar clockwise (one full turn will decrease insertion depth by 1/16 in.), and tighten the hex nut.
- b. NOT DEEP ENOUGH — loosen the hex nut in the closing-height collar, rotate the collar counterclockwise (one full turn will increase insertion depth by 1/16 in.), and tighten the hex nut.

5. TERMINATING PROCEDURE

A. Discrete Wire Application

1. Spread connector holding fixture and insert connector into center of fixture as shown in Figure 4.
2. Lace individual wires straight through the front and rear comb.
3. Lower ram until collar bottoms on frame assembly.
4. Raise ram and remove the terminated connector.

B. Ribbon Cable Application

NOTE

The front and rear plastic combs of the connector holding fixture must be altered for ribbon cable applications.

1. Remove or cut off rear comb of connector holding fixture for use in feed-through applications. See Figure 4.
2. Cut off teeth of front comb of connector holding fixture. Do NOT cut off the guide posts.
3. Spread connector holding fixture and insert connector.
4. Notch the ribbon cable using AMP Cable Notching Tool 59835-1. See AMP Instruction Sheet IS 6521 for specific notching instructions.
5. Center notched area on the connector and lower the ram until the collar bottoms on the frame assembly.
6. Raise the ram and remove the terminated connector.

This completes the termination procedure.

NOTE

The connector holding fixture with the cutoff can be used for end-of-line ribbon cable applications. Care must be taken to locate the cable against the cable stop of the connector.

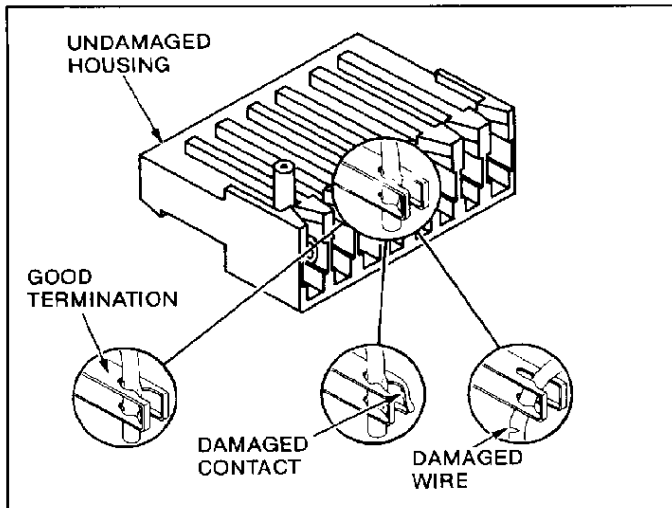

Fig. 5

6. INSPECTION

1. Inspect housing and contacts for physical damage. See Figure 5.
2. Inspect connector according to Application Specification 114-1019 which pertains to MTA connectors.

7. TOOLING ASSEMBLY CERTIFICATION

AMP Tooling Assembly 58040-1 should be certified with the information provided in Figure 6. It is recommended that the tooling assembly be inspected immediately upon arrival at your facility (and at regularly scheduled intervals) to ensure that the tooling assembly has not been damaged during handling.

The parts listed in Figure 6 can be replaced by qualified personnel at your facility or at our tool repair facility. All tooling parts that are NOT listed must be replaced or repaired by qualified AMP Personnel.

When returning tooling to AMP Incorporated for repair, carefully package the tool along with a written description of the problem and send to:

AMP Incorporated
 Customer Repair
 1523 North 4th Street
 Harrisburg, PA 17102-1604

or a wholly owned subsidiary of AMP Incorporated.

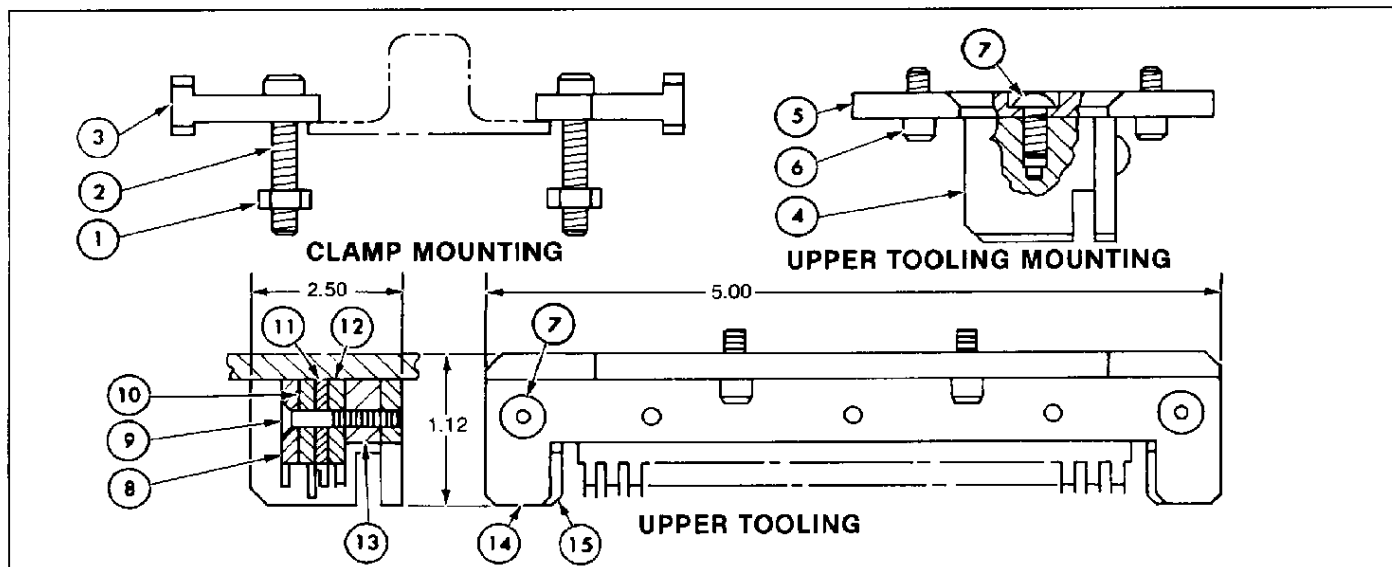

TOOL NUMBER	PRODUCT DESIGNED FOR	CUSTOMER REPLACEABLE PARTS			
		ITEM	PART NO.	DESCRIPTION	QTY
58040-1	AMP MTA 156 Connectors	1	21018-6	NUT, Hex	2
		2	3- 21000-1	SCREW, Skt Hd Cap, 1.00 L	2
		3	311976-1	CLAMP	2
		4	311978-1	LOCATOR, End	1
		5	311973-1	TOOLING, Upper	1
		6	1- 21000-9	SCREW, Skt Hd Cap, .38 L	4
		7	2- 21002-1	SCREW Skt Btn Hd Cap, .38 L	4
		8	310373-1	STUFFER, Insulation	1
		9	1- 21003-7	SCREW, Flat Skt Hd Cap	3
		10	311583-1	STUFFER, Side of Contact	1
		11	311983-1	STUFFER, Thru Contact	1
		12	310371-2	BLADE, Cutoff	1
		13	311975-2	SPACER	1
		14	311974-2	PLATE, Side	1
		15	311977-1	LOCATOR, End	1
Engineering Approval	Date				
Doug Leiby	6-9-87				

Fig. 6