

**Board Support Fixture Assembly**

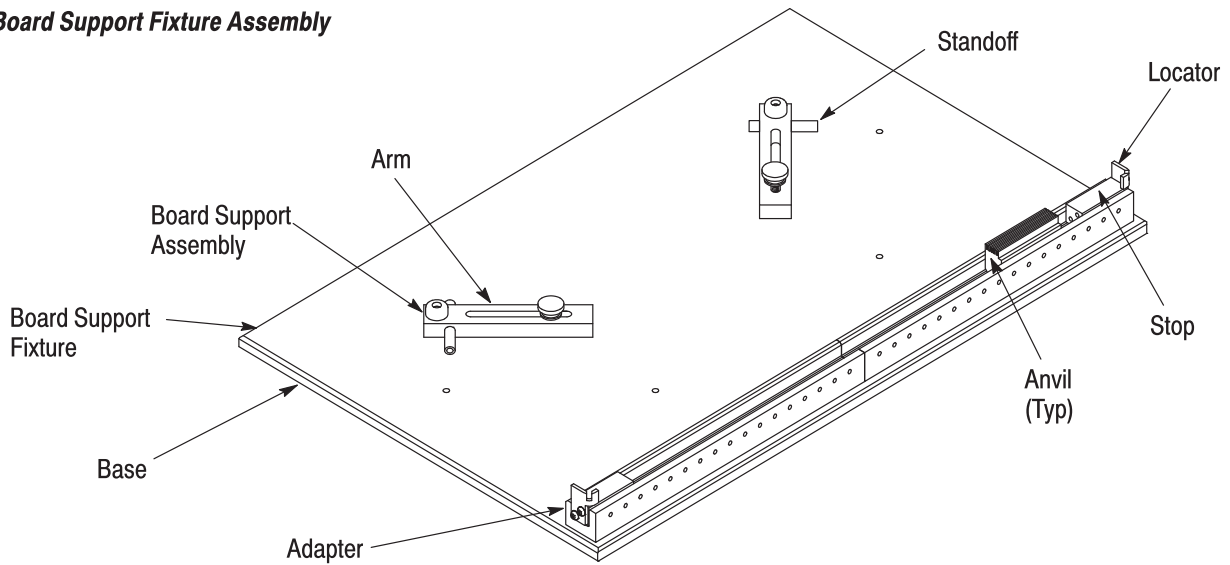

Figure 1

**1. INTRODUCTION**

This instruction sheet covers the assembly and the proper mounting of a Printed Circuit (pc) board support fixture 679980-[ ] to a SM-3 Bench Seating Machine 814700-2, to a 10/20-Ton H-Frame Power Unit Machine 803880-6, or to an arbor press equipped with a table suitable to accommodate the fixture. (Fixture 679980-3 cannot be used with the SM-3 Machine.) The fixture is used to help assemble pre-assembled Z-PACK connectors to pc boards. Read these instructions and review the illustrations thoroughly before applying power to the machine. See Figure 1.



All dimensions on this document are in millimeters [with inches in brackets].

Reasons for reissue of this document are provided in Section 6, REVISION SUMMARY.

**2. DESCRIPTION** (Figure 2)

The pc board support fixture is custom-designed from an aluminum tooling plate. The fixture part number 679980 comes in three sizes; -1 for 9-inch wide pc board, -2 for 18-inch wide pc board, and -3 for 23-inch wide pc board.

This fixture is used in conjunction with various anvils to seat the following right angle connectors and shields:

- FB right angle connectors.

- Z-PACK HM right angle connectors with ACTION PIN\* Contacts.
- Z-PACK HM upper and lower shields for right angle contacts.
- Right angle connectors with ACTION PIN Contacts.

DESCRIPTION	FIXTURE PART NUMBER	SIZE
PC Board Support Fixture	679980-1	304.8 x 241.3 [12 x 9.50]
	679980-2	304.8 x 469.9 [12 x 18.50]
	679980-3	304.8 x 596.9 [12 x 23.50]

Figure 2

Tyco Electronics offers this fixture to aid in the preparation of the pc board and connector for insertion by a press. Some features are:

- Allows quick, accurate pc board alignment. There is an adjustable mechanism on the front of the fixture that positions the board along the left and right edges.
- Easily adaptable to various pc board sizes with connectors configured anywhere along the length of the board. Three fixtures are offered; -1 for 9-inch wide pc board, -2 for 18-inch wide pc board, and -3 for 23-inch wide pc board.

- The fixtures include bottom side clearance and support tooling for the connector leads and retention features.
- The front edge of the board is positioned by the board locator features and the bottom side of the pc board is supported by anvils along with adjustable standoffs. These standoffs can be moved into various support positions that do not interfere with components on the bottom side of the pc board.
- The board and connector are placed on the fixture, which is then slid under the press and under the flat metal bar. Press actuation inserts the connector into the board.

### 3. SUPPORT FIXTURE ASSEMBLY (Figure 3)

The side locators (items 4 and 9) located on item 8, are positioned in the adaptor (item 2) to accommodate the width of the pc board. Then the anvil or anvils (item 6) which match the connector are positioned in the adapter (item 2). Set screws (item 7) retain anvils. The board standoffs (items 13 and 14) are positioned to balance and support the board.

## 4. MACHINES

A commercially available machine with appropriate capacity can be used for pressing receptacle connectors or shields into a board. Tyco Electronics offers pneumatic and hydraulic machines for high volume applications.

### 4.1. High Volume Applications

SM-3 Machine 814700-2 is a pneumatic machine capable of applying 26,689 N [6000 lb] force. Below are the features:

- Table top unit: 673 mm H x 902 mm L x 584 mm W [26.5 in. H x 35.5 in. L x 23 in. W]; Weight 132 kg [290 lb.].
- Two pushbuttons must be depressed to actuate the machine.
- Totally pneumatic – air requirement is 552 kPa [80 psi].
- PC board thickness and ram height controlled manually in conjunction with either board or pressure sensing.
- Accepts 457.2 mm X 609.6 mm [18 in. X 24 in.] board size.
- Cycle time of 4 seconds.

For additional information, order customer manual 409-5626.

H-Frame Machine 803880-6 is a hydraulically-operated machine capable of applying 177,929 N [40,000 lb] force. Below are the features:

- 1.96 m H x 1.85 m L x 1.14 m W [77 in. H x 73 in. L x 45 in. W]; Weight 991 kg [2185 lb].
- Two pushbuttons must be depressed to actuate the machine.
- Accepts 1.09 m x 1.14 m [43 in. x 45 in.] board size.
- Cycle time of 2 to 2.5 seconds.

For additional information, order customer manual 409-5567.

### 4.2. Manual Operation

Tyco Electronics sells adapter kits for use with the Greenerd frame assemblies 3A and 3B. The arbor presses are manually operated and can apply a force of 26,689 N [6000 lb]. The kit includes a ram adapter assembly kit, a counterbalance kit, and a board support plate. See instruction sheet 408-9027 for additional information. For more information on the Greenerd presses, contact:

Greenerd Press and Machine Co., Inc.  
41 Crown Street  
Nashua, NH 03061

## 5. REPLACEMENT AND REPAIR

The parts listed in Figure 3 are customer-replaceable. A complete inventory can be stocked and controlled to prevent lost time when replacement of parts is necessary. Order replacement parts through your Tyco Electronics Representative, or call 1-800-526-5142, or send a facsimile of your purchase order to 1-717-986-7605, or write to:

CUSTOMER SERVICE (38-35)  
TYCO ELECTRONICS CORPORATION  
P.O. BOX 3608  
HARRISBURG PA 17105-3608

Tools may also be returned for evaluation and repair. For tool repair service, contact a Tyco Electronics Representative at 1-800-526-5136.

## 6. REVISION SUMMARY

Since the previous release of this document, the following additions were made:

- Updated document to corporate requirements

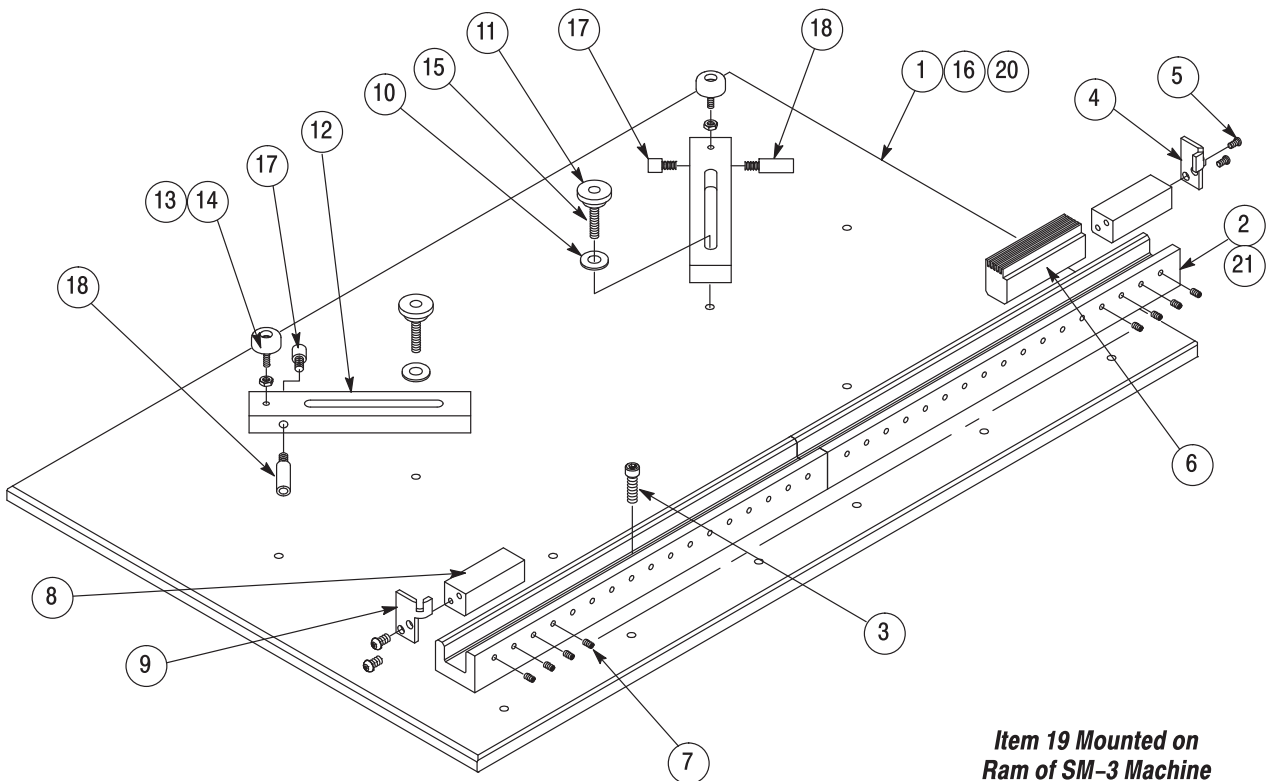

**Item 19 Mounted on Ram of SM-3 Machine**

ITEM NUMBER	PART NUMBER	DESCRIPTION	QUANTITY PER ASSEMBLY		
			679980-1	679980-2	679980-3
1	679979-1	BASE	---	1	---
2	679975-1	ADAPTOR	1	2	2
3	3-21000-4	SCR, SHC 10-32 X .38 lg.	3	6	8
4	679976-1	LOCATOR, Board, (RH)	1	1	1
5	1-21002-7	SCR, BHC 6-32 X .38 lg.	4	4	4
6	679978-1 ■	ANVIL, Board Support	Ref	Ref	Ref
7	2-21006-9	SCR, SOC. SET 6-32 X .25 lg.	17	34	45
8	679981-1	STOP, End	2	2	2
9	679986-1	LOCATOR, Board (LH)	1	1	1
10	21899-2	WASHER, Flat	2	2	2
11	27708-4	KNOB, Thumbscrew	2	2	2
12	679983-1	ARM, Support	2	2	2
13	21018-5	NUT, Hex 6-32	2	2	2
14	811242-2	BUMPER, Hold Down	2	2	2
15	3-21000-7	SCR, SHC 10-32 X .75 lg.	2	2	2
16	122447-1	BASE	1	---	---
17	28085-8	STANDOFF, Male-Female	2	2	2
18	1-28085-1	STANDOFF, Male-Female	2	2	2
19	122560-1	SUPPORT, Tool (Located on ram of SM-3 machine)	Ref	Ref	Ref
20	904807-1	BASE	---	---	1
21	904808-1	ADAPTOR	---	---	1

■ Determined by Connector Part Number

Figure 3