

## 3M Assembly Press Model 3830

### General

The 3M Model 3830 pneumatic press has been designed for the assembly of 3M connectors to flat and round jacketed cable. When used for this purpose, it will provide excellent service and requires a minimum amount of maintenance.

### Safety

The 3830 Pneumatic Press has been designed for safe operation. However, the operator should practice safe work habits while working with the 3830 Pneumatic Press.

Do not operate the 3830 Pneumatic Press when another person is assisting you.

### Installation

1. Locate the tube fitting extending from the back of the press. (See Figure 4)
2. Insert the plain end of the air supply assembly tube into the tube fitting. (See Figure 3)

**NOTE:** This fitting is a quick connect/disconnect style. Pushing the tube into the fitting locks the tube in place and provides an airtight seal. To disconnect the tube be sure that the wall fitting is disconnected then push the green cap in toward the press and at the same time pull the tube from the fitting.

3. Attach the wall fitting to the shop air supply.

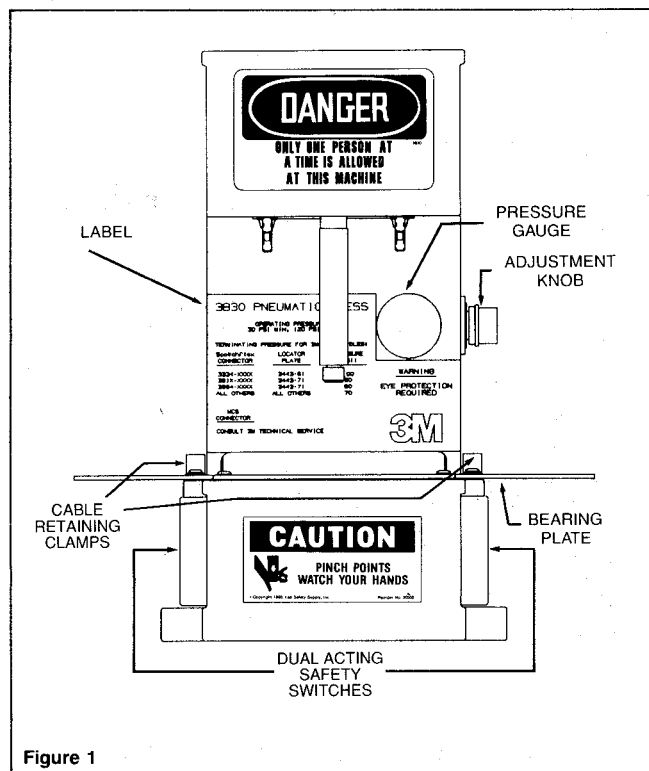

Figure 1

## Adjustments

Turn the ON/OFF switch to "ON". Observe the pressure gauge. Adjust the pressure using adjustment knob located toward the rear and in the middle of the right side of press (Figure 1). Follow the guidelines for Operating Pressure as established on the label located on the machine face (Also shown on Figure 1).

NOTE 1: The red snap ring on the adjustment knob is a lock. Push the snap ring "in" to lock, pull it "out" to unlock.

NOTE 2: If non-3M cable is used, additional adjustments may be required.

## Connector Assembly

1. Place the desired locator plate on the Bearing Plate. (See Figure 1)
2. Attach the appropriate Platen to the Press Shaft. Prepare the cable and connector cover sub assembly.
3. Place the cable-connector sub assembly into the locator plate.
4. Position the cable springs over the cable to hold long cables if needed. (See Figure 4)

NOTE: Power should be "ON". Refer to ADJUSTMENTS above.

## Operation

To cycle the machine both actuation buttons (green buttons toward the front and on either side of the machine-See Figure 2) must be depressed simultaneously within 0.2 seconds. Release of both or either button causes the cylinder shaft to retract.

## Maintenance

To obtain the best efficiency and longest periods of trouble-free operation, the air supply must be kept clean. Dirt is the most common cause of erratic operation.

## Air System

The air filter has an automatic drain. It is not necessary to disassemble filter regulator for draining oil from the air supply system. However, a catch pan may be necessary if large quantities of oil are in the air supply system.

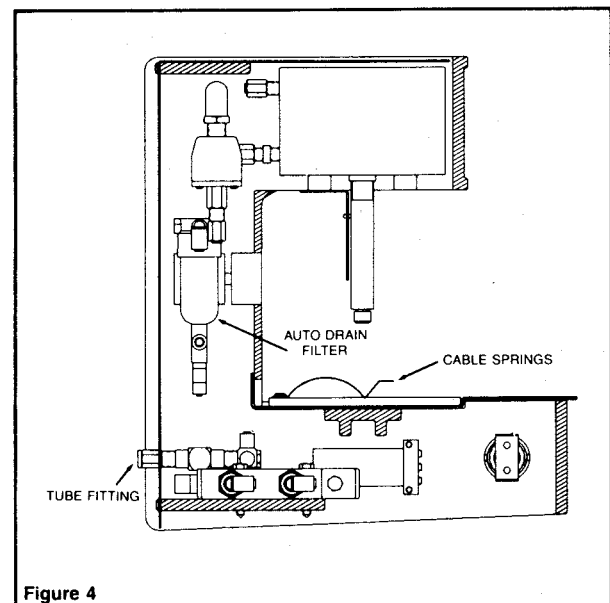
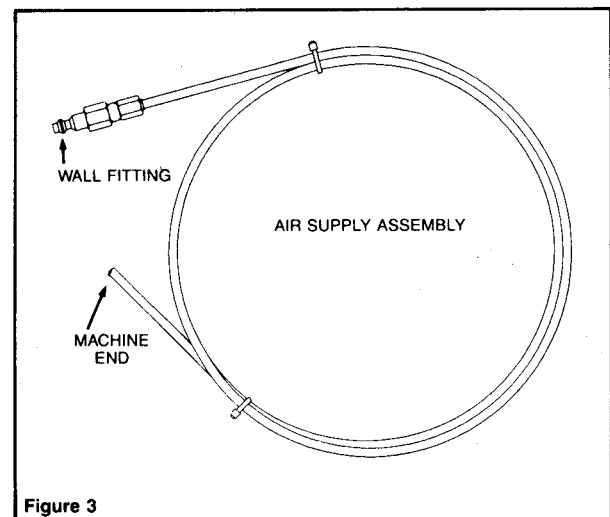
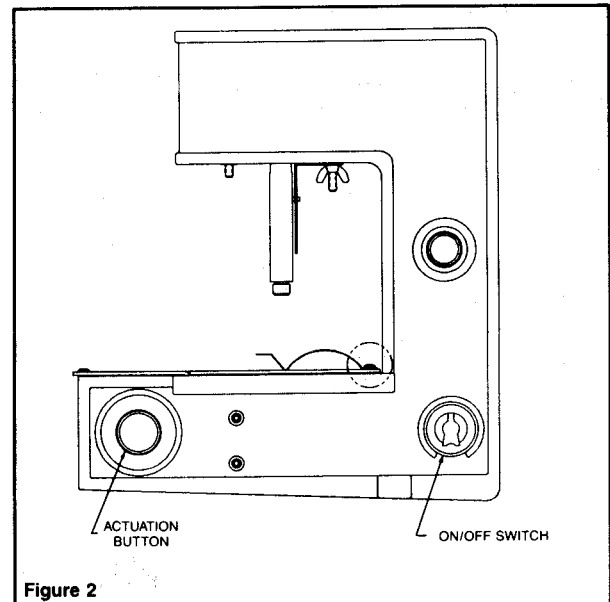



## BILL OF MATERIALS

ITEM	BM	PART NUMBER	QTY	CM	DESCRIPTION	CIRCUIT AREA
0	X	078-8054-5881-3	1		SUB-ASSEMBLY, PNEUMATIC CIRCUIT	
1		26-1005-7642-5	1	X	FILTER, 1/8", AUTO DRAIN, (NORGREN #F07-100-A1M)	GENERAL POWER
2		26-1001-7170-6	1	X	ELBOW, MALE, 1/4 O.D. TUBE X 1/8 MNPT, (LEGRIS #3109-56-11)	GENERAL POWER
3		26-1005-7651-6	1	X	ELBOW, MALE, 1/8 MNPT X 1/8 MNPT, (ANDERSON #116-AM-A)	GENERAL POWER
4		26-1005-7643-3	1	X	REGULATOR WITH GAUGE, 1/8" (NORGREN #R07-100-RGKA)	GENERAL POWER
5		26-1005-7645-8	1	X	RUN TEE, MALE, 1/4 O.D. TUBE X 1/4 O.D. TUBE X 1/8 MNPT, (LEGRIS #3103-56-11)	GENERAL POWER
6		26-1005-7647-4	1	X	ELBOW, MALE, 1/4 O.D. TUBE X 1/8 MNPT, (LEGRIS #3018-56-11 BANJO)	GENERAL POWER
7		26-0001-7853-8	1	X	VALVE, ON/OFF, 3-WAY, (GENERANT #OE 41)	GENERAL POWER
8		26-1003-7734-5	2	X	CONNECTOR, MALE, 1/4 O.D. TUBE X 1/8 MNPT, (LEGRIS #3115-56-11)	GENERAL POWER, EXTEND POWER, RETURN POWER
9		26-1005-7648-2	1	X	CAP (LEGRIS #3330-56-02)	GENERAL POWER
10		26-1005-7700-1	2	X	BUTTON HEAD, FLUSH, GREEN (CROUZET #24 679 402)	PILOT
11		26-1005-7701-9	2	X	SWITCH BODY WITH ADAPTOR, NC (CROUZET #89 545 101)	PILOT
12		26-1005-7702-7	1	X	SINGLE SUBPLATE (CROUZET #81 532 001)	PILOT
13		26-1005-7703-5	1	X	TWO HAND CONTROL MODULE (CROUZET #81 580 101)	PILOT
14		26-1005-7644-1	1	X	VALVE, SPRING RETURN (NORGREN #K71DA00-KS6-KA2)	PILOT
15		26-1005-7704-3	1	X	PLUG IN "Y", MALE X FEMALE, 1/4 M X 5/32 F X 5/32 F (LEGRIS #3142-04-56)	PILOT
16		26-1003-7731-1	3	X	ELBOW, MALE, 1/4 TUBE O.D. X 1/4 MNPT, (LEGRIS #3109-56-14)	EXTEND POWER, RETURN POWER,
17		26-1005-7650-8	1	X	FABCO MINI MUFF MUFLER #MM 14	EXTEND POWER
18		26-1005-7649-0	1	X	FABCO PANCAKE CYLINDER #C 1221-X, MODIFIED: 3/8 NPT RETURN, W/ 1/4 ORIFICE, STANDARD EXTEND	RETURN POWER
19		A78-8054-5990-2	2		5/32 O.D., NYLON TUBING, BLACK, 16.0 LG	PILOT
20		A78-8054-5991-0	2		5/32 O.D., NYLON TUBING, RED, 5.5 LG	PILOT
21		A78-8054-5992-8	1		5/32 O.D., NYLON TUBING, RED, 10.0 LG	PILOT
22		A78-8054-5993-6	1		1/4 O.D., POLY TUBING, BLACK, 15.0 LG	EXTEND POWER
23		A78-8054-5994-4	1		1/4 O.D., POLY TUBING, BLACK, 12.0 LG	RETURN POWER
24		A78-8054-5995-1	1		1/4 O.D., POLY TUBING, BLACK, 8.0 LG	GENERAL POWER
25		A78-8054-5996-9	1		1/4 O.D., POLY TUBING, BLACK, 7.0 LG	GENERAL POWER
26		78-8032-2327-6	1	X	AR TFLON TAPE, 1/2" WIDE, 3.5 MIL THK (3M 5490)	
27		26-1002-3355-5	1	X	PANEL NUT (NORGREN #2962-89)	GENERAL POWER
28		26-1005-8078-1	1	X	FABCO MINI MUFF #MM 38	RETURN POWER
29		26-1005-8121-9	1	X	FABCO BREATHER #MB 14	RETURN POWER
30		26-1005-8120-1	1	X	CONNECTOR, MALE, 1/4 OD TUBE X 3/8 MNPT (LEGRIS #3115-56-18)	RETURN POWER
31		12-7997-4211-4	1	X	NIPPLE, BRASS, 3/8 MNPT X 3/8 MNPT (PARKER HANNIFIN #215 PN-6)	RETURN POWER
32		26-1005-8079-9	1	X	QUICK EXHAUST, 3/8 NPT (HUMPHREY #OE 3)	GENERAL POWER
33		26-1005-9158-0	1	X	CONNECTOR, MALE, 5/32 OD TUBE X 1/8 MNPT (LEGRIS #3115-04-11)	PILOT

### Important Notice

All statements, technical information and recommendations related to the Seller's products are based on information believed to be reliable, but the accuracy or completeness thereof is not guaranteed. Before utilizing the product, the user should determine the suitability of the product for its intended use. The user assumes all risks and liability whatsoever in connection with such use.

Any statements or recommendations of the Seller which are not contained in the Seller's current publications shall have no force or effect unless contained in an agreement signed by an authorized officer of the Seller. The statements contained

herein are made in lieu of all warranties, express or implied, including but not limited to the implied warranties of merchantability and fitness for a particular purpose which warranties are hereby expressly disclaimed.

SELLER SHALL NOT BE LIABLE TO THE USER OR ANY OTHER PERSON UNDER ANY LEGAL THEORY, INCLUDING BUT NOT LIMITED TO NEGLIGENCE OR STRICT LIABILITY, FOR ANY INJURY OR FOR ANY DIRECT OR CONSEQUENTIAL DAMAGES SUSTAINED OR INCURRED BY REASON OF THE USE OF ANY OF THE SELLER'S PRODUCTS THAT WERE DEFECTIVE.