

Instructions for adjustment and use of Scotchflex Assembly Press Model #3335

Please Note: Scotchflex Assembly Presses have been designed specifically for the assembly of Scotchflex electronic connectors to flat cable. When used for this purpose they will provide excellent service and require a minimum of maintenance. The presses should never be used to perform other shop functions. All assembly presses have four mounting holes in the base for securing to a bench.

General:

The recommended platen and its position is included on the instruction sheet. The standard platen, #3442-1A, is provided with the assembly press and is used for the assembly of most Scotchflex connectors. Other platens necessary for certain Scotchflex connectors are available through your Scotchflex representative.

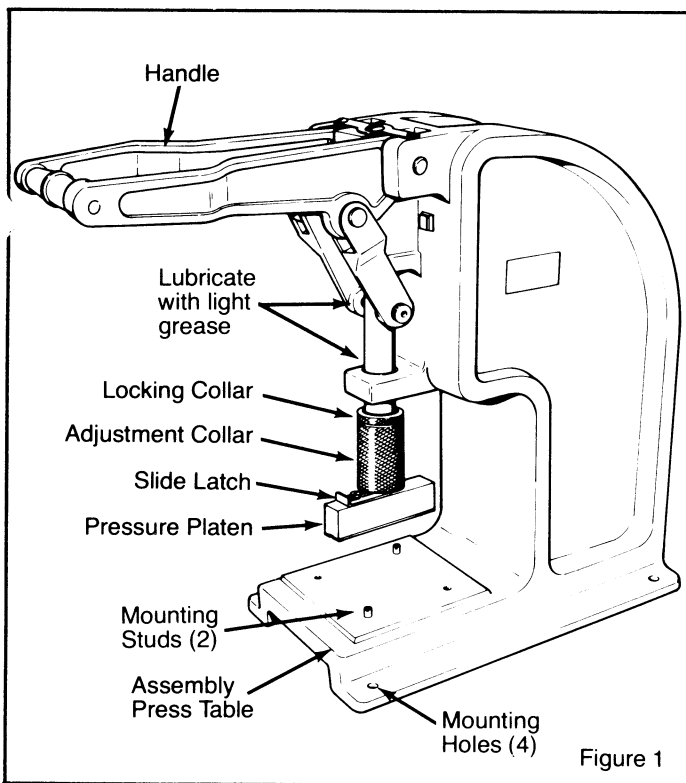

Figure 1

Procedure for Adjusting Shut Height Assembly Press Model: 3335

Note: The shut height must always be made with the specific locator plate in position.

1. Pull back the slide latch and remove pressure platen. (see figure 1)
2. Loosen the knurled locking collar of the adjustment shaft assembly.
3. Lower the handle fully. The arms will stop against the casting.

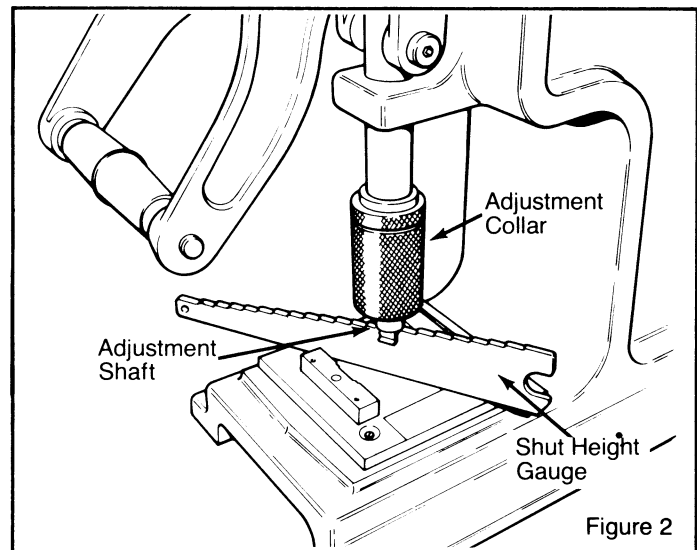
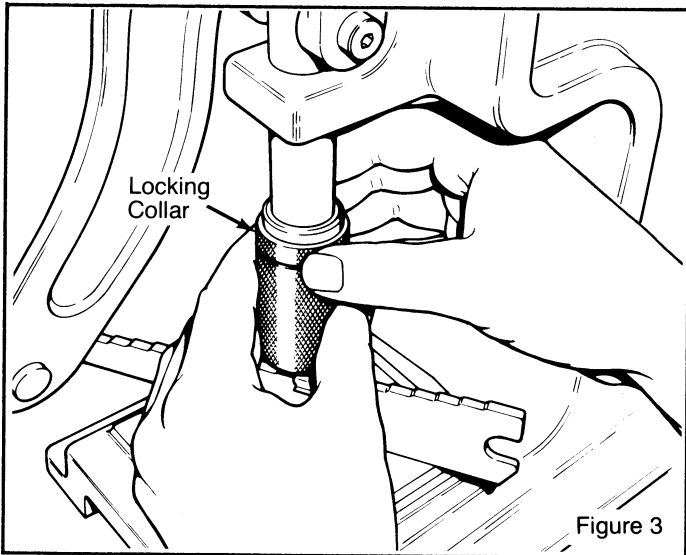

Figure 2

4. Place the #3436-1A shut height gauge supplied with the assembly press across the locator plate and rotate the knurled adjustment collar until the adjustment shaft contacts the desired position on the gauge. The shut height gauge should be able to slip with slight resistance. (see figure 2)



5. Rotate the locking collar firmly against the adjustment collar, securing the adjustment setting (see figure 3)
6. Replace the pressure platen in either of two positions, referring to the adjustment setting sheet for the correct position. Most positions are parallel to the length of the connector.

Maintenance:

It is not necessary to disassemble the press for lubrication. Apply a few drops of S.A.E. 10 oil on the six pivot points at least every 5,000 connections. Apply a small amount of light grease to the shaft near the bearing areas.

Figure 3

Important Notice to Purchaser

All statements, technical information and recommendations contained herein are based on tests we believe to be reliable, but the accuracy or completeness thereof is not guaranteed, and the following is made in lieu of all warranties, expressed or implied.

Seller's and manufacturer's only obligation shall be to replace such quantity of the product proved to be defective. Neither seller nor manufacturer shall be liable for any injury, loss or damage, direct or consequential, arising out of the use of or the inability to use the products. Before using, user shall determine the suitability of the product for his intended use, and user assumes all risk and liability whatsoever in connection therewith.

No statement or recommendation not contained herein shall have any force or effect unless in an agreement signed by officers of seller and manufacturer.

34-7013-8050-2A

Litho in U.S.A. with 3M BRAND Photo Offset Plates, Film and Chemicals.

Electronic Products Division/3M
3M Center, St. Paul, MN 55101