

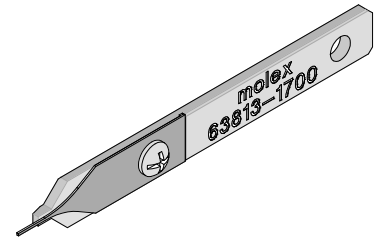

Extractor Tool

**Application Tooling
Specification Sheet**



Order No. 63813-1700

FEATURES

- This Extractor Tool is for the removal of Pico-Clasp™ terminals from Pico-Clasp™ housing (1.00mm (.039") Pitch Wire-to-Board Housing).

SCOPE

Products: 1.00mm (.039") Pitch Pico-Clasp™ Wire-to-Board Crimp Terminals, 28-32 AWG.

Terminal Series No.	Housing Series No.	Terminal Order No.		Housing Order No.			
501193	501189	501193-0000, 501193-0100	501193-2000	501189-2010	501189-3010	501189-4010	501189-5010
501334	501330, 501939	501334-0000	501334-0100	501330-0200	501330-0300	501330-0400	501330-0500
				501330-0600	501330-0632	501330-0633	501330-0634
				501330-0636	501330-0637	501330-0638	501330-0639
				501330-0700	501330-0732	501330-0733	501330-0734
				501330-0736	501330-0737	501330-0738	501330-0739
				501330-0800	501330-0832	501330-0833	501330-0834
				501330-0836	501330-0837	501330-0838	501330-0839
				501330-0900	501330-0932	501330-0933	501330-0934
				501330-0936	501330-0937	501330-0938	501330-0939
				501330-1000	501330-1032	501330-1033	501330-1034
				501330-1036	501330-1037	501330-1038	501330-1039
				501330-1100	501330-1132	501330-1133	501330-1134
				501330-1136	501330-1137	501330-1138	501330-1139
				501330-1200	501330-1232	501330-1233	501330-1234
				501330-1236	501330-1237	501330-1238	501330-1239
				501330-1300	501330-1332	501330-1333	501330-1334
				501330-1336	501330-1337	501330-1338	501330-1339
				501330-1400	501330-1432	501330-1433	501330-1434
				501330-1436	501330-1437	501330-1438	501330-1439
				501330-1500	501330-1532	501330-1533	501330-1534
				501330-1536	501330-1537	501330-1538	501330-1539
				501939-0300	501939-0330	501939-0331	501939-0332
				501939-0333	501939-0334	501939-0336	501939-0337
				501939-0338	501939-0339	501939-0400	501939-0430
				501939-0431	501939-0432	501939-0433	501939-0434
				501939-0436	501939-0437	501939-0438	501939-0439
				501939-0500	501939-0530	501939-0531	501939-0532
				501939-0533	501939-0534	501939-0536	501939-0537
				501939-0538	501939-0539		

OPERATION:

1. Push the terminal and the wire forward in the arrow direction before using the Extractor Tool.
2. Insert the Extractor Tool into the slot below the terminal until the stop on the tool contacts the plastic housing as shown in Figure 1. This will flex the plastic lance freeing the terminal.

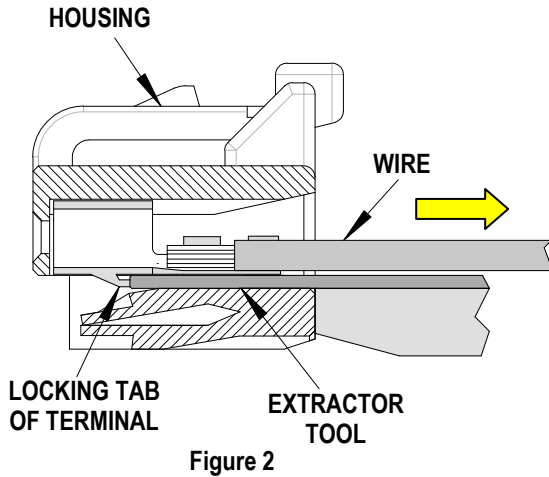
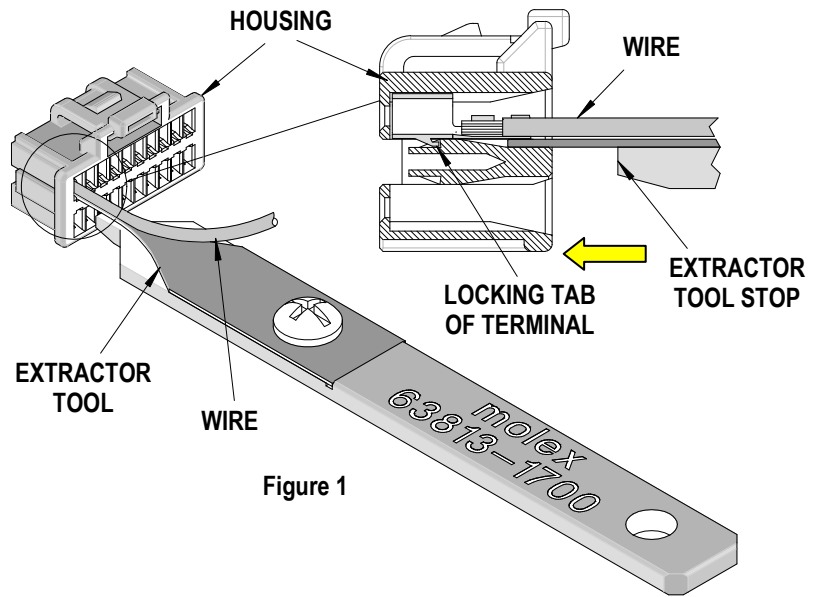

Note: Please do not forcefully insert, insert on an angle, or insert with twisting action. It may damage the tool or the housing.

3. Holding the wire and the tool together, pull the wire and the tool back through the connector slot in the arrow direction as shown in Figure 2.
4. Molex does not offer repair parts for Extractor Tools due to the inexpensive nature of the tool.

CAUTION: Molex crimp specifications are valid only when used with Molex terminals and tooling.

<http://www.molex.com>