

INSTRUCTIONS FOR THE INSTALLATION OF SOCKET EJECTOR LATCH

GENERAL: Socket ejector latches are available in two lengths. The shorter #3505-2 is used on SCOTCHFLEX headers having a suffix -1202, -1203, -2202, -2203, -3205 and -4205. The longer #3505-3 is used on headers having a suffix -1302, -1303, -2302, -2303, -3305 and -4305.

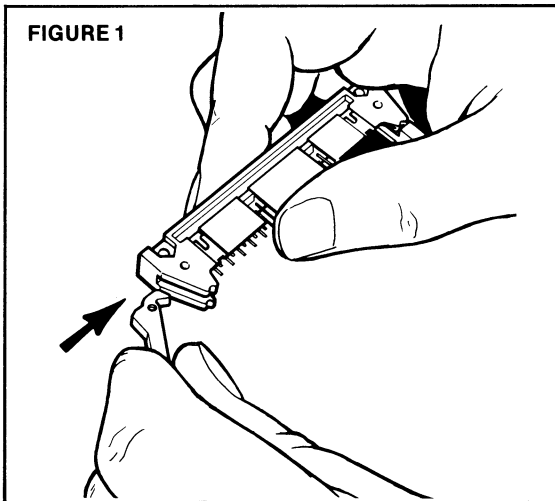

1. Insert socket ejector latch into end of header with ejector foot toward header pins. (Figure 1)

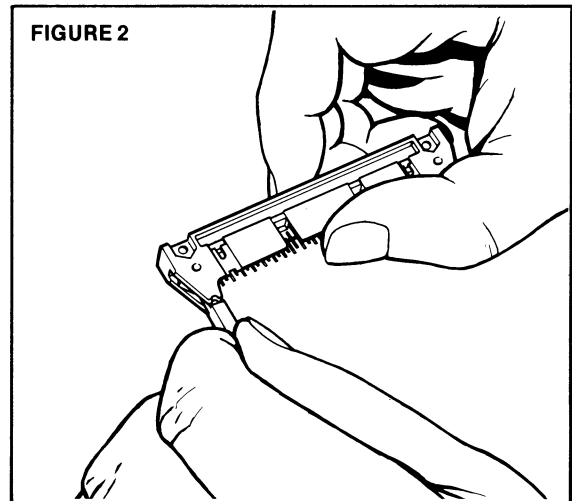

2. Position ejector latch so that knob is seated in header notch. (Figure 2) This will align latch hole with header pivot hole.

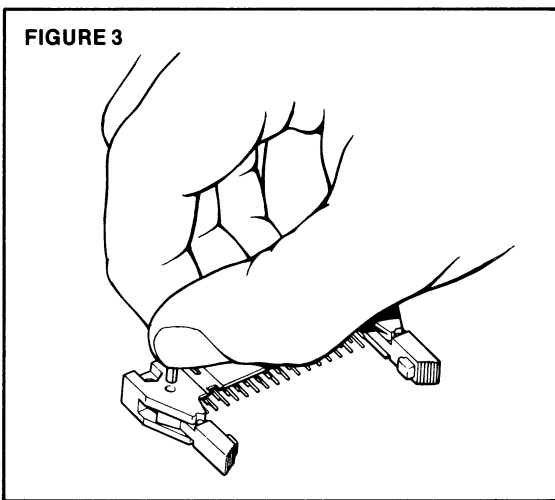

3. Place roll pin into header pivot hole, and press in slightly. (Figure 3)

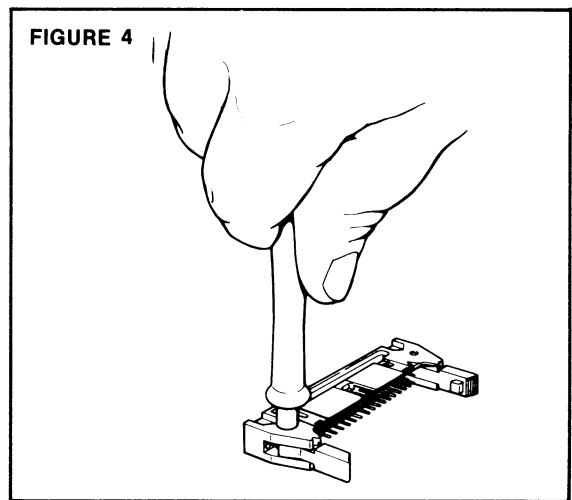

4. With header on a firm surface, locate tip of the 3430-4000 hand tool into roll pin and depress tool firmly. (Figure 4) The pin should be flush with header when fully inserted.

Electronic Products Division **3M**
COMPANY
3M CENTER • SAINT PAUL, MINNESOTA 55101