

PROPER USE GUIDELINES

Cumulative Trauma Disorders can result from the prolonged use of manually powered hand tools. Hand tools are intended for occasional use and low volume applications. A wide selection of powered application equipment for extended-use, production operations is available.

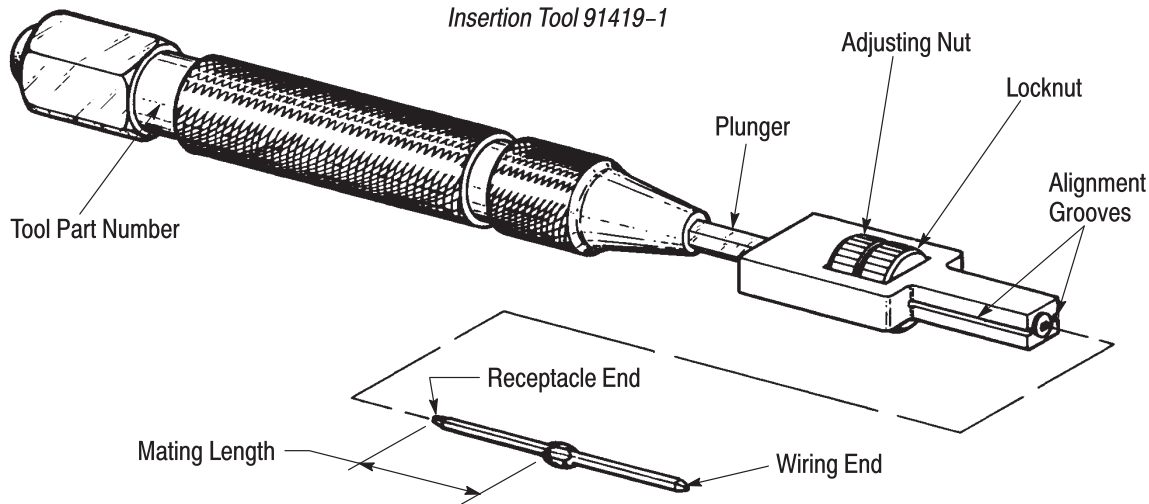

Figure 1

1. INTRODUCTION

This instruction sheet covers the use of Uninsulated Bandolier Post Insertion Tool 91419-1 which are designed to insert the loose-piece version of AMPMODU* .025 Square Post with Bandolier Carrier Strip onto printed circuit (pc) boards or panels. This insertion tool is used with posts having a mating length ranging from 5.97-11.43 [.235-.450]. See Figure 1. Read these instructions carefully before using the tool.

NOTE

Dimensions in these instructions are in metric units [with inches in brackets]. Figures are for reference only and are not drawn to scale.

Reasons for reissue of this instruction sheet are provided in Section 6, REVISION SUMMARY.

2. DESCRIPTION

The insertion tool consist of a spring-loaded plunger and a receptacle tip which forces the uninsulated posts into the pc board. The tip features an adjusting nut and a locknut which allows adjustment for various post lengths. In order to activate the impact mechanism, 53.38-57.83 N [12-13 lb-force] is required.

A pc board (or panel) support should be used during insertion. Make certain that the support is deep enough to receive the fully inserted posts.

DANGER

Do NOT depress the tool handle when the tool is not being used to insert a post. Doing so may cause injury or damage to the tool.

3. INSERTION PROCEDURE (Figures 2 and 3)

1. Check the mating length of the post, then adjust the tip insertion depth as follows:

(a) Loosen the locknut and rotate the adjustment nut (see Figure 1) until the proper insertion depth is achieved. Use the formula given in Figure 2 as a guide.

(b) When the proper insertion depth is achieved, retighten the locknut against the adjustment nut.

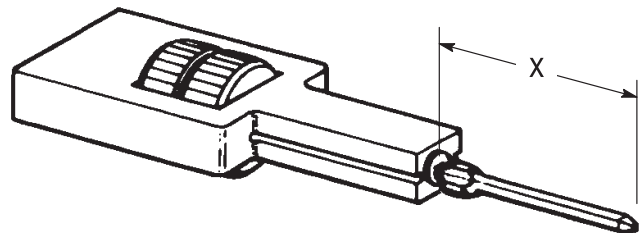

$$X = \text{Total Post Length} - (\text{minus}) \text{Mating Length (Receptacle End)} - (\text{minus}) 0.15 [.006].$$

Figure 2

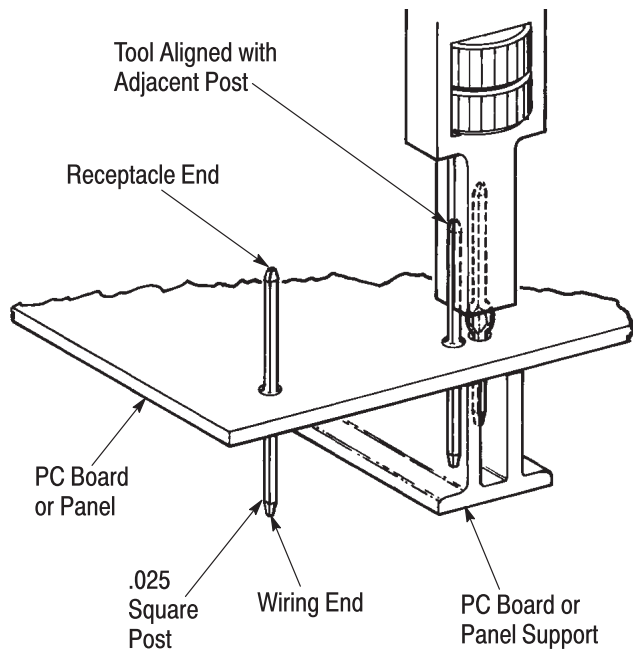

Figure 3

2. Push the wiring end of the post into the pc board, making sure it is retained and aligned in the board.
3. Fit the tip of the impact tool over the receptacle end of the post, making sure the tip is oriented the same as adjacent posts. See Figure 3.
4. Holding the tool and post perpendicular to the pc board, use a straight steady motion and depress the handle until the tool trips. Release the handle, allowing the handle to retract. The post is fully inserted when the tool tip bottoms on the pc board.

NOTE

If inserting the post into a thick pc board, it may be necessary to depress the handle several times (repeating step 4) to ensure proper insertion.

5. Using Tyco Electronics' Application Specification 114-25024, inspect the inserted post for full and proper insertion.

4. TOOL CERTIFICATION

This tool should be certified with the information provided in Figure 4. Tyco Electronics recommends that you inspect the tool immediately upon arrival in your factory and at regular scheduled intervals to ensure that the tools have not been damaged during handling.

5. REPAIR/REPLACEMENT

A complete inventory should be stocked and controlled to prevent lost time when replacement of parts is necessary. Parts other than those listed in Figure 4 should be replaced by Tyco Electronics to ensure quality and reliability. Order additional tools or replacement parts through your Tyco Electronics Representative, or call 1-800-526-5142, or send a facsimile of your purchase order to 717-986-7605, or write to:

CUSTOMER SERVICE (038-035)
 TYCO ELECTRONICS CORPORATION
 PO BOX 3608
 HARRISBURG PA 17105-3608

6. REVISION SUMMARY

- Updated document to corporate requirements
- Deleted obsolete part number 91419-2 and related information

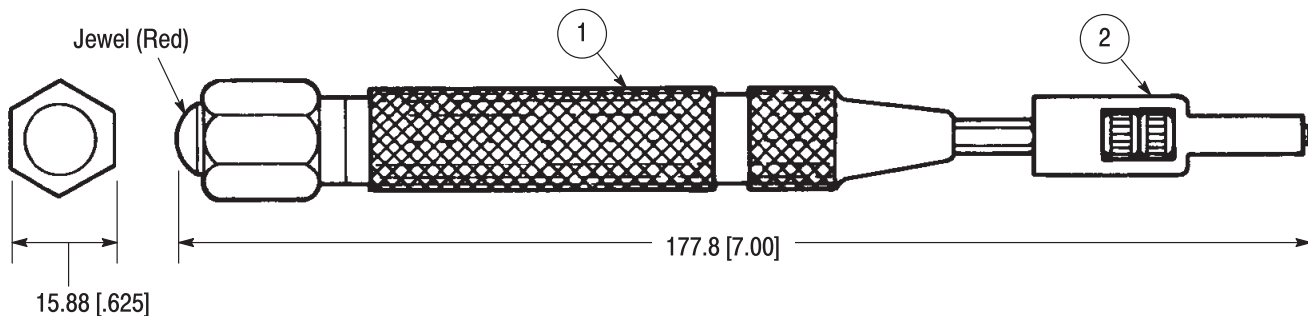

CUSTOMER REPLACEABLE PARTS FOR UNINSULATED BANDOLIER POST INSERTION TOOL 91419-1

ITEM NO.	PART NUMBER	DESCRIPTION	QTY PER ASSEMBLY	TOOL WEIGHT
1	126007-2	INSERTION TOOL, Subassembly	1	0.28 kg [10 oz.]
2	527256-1	INSERTION TIP, Short Post	1	

Figure 4