



**A-MP★ EXTRACTION TOOL 91040-7
FOR REMOVING
COAXICON★ SOCKET CONTACTS
FROM ARINC TYPE CONNECTORS**

IS 7417	
RELEASED	9.15.69
REVISED	10.20.69

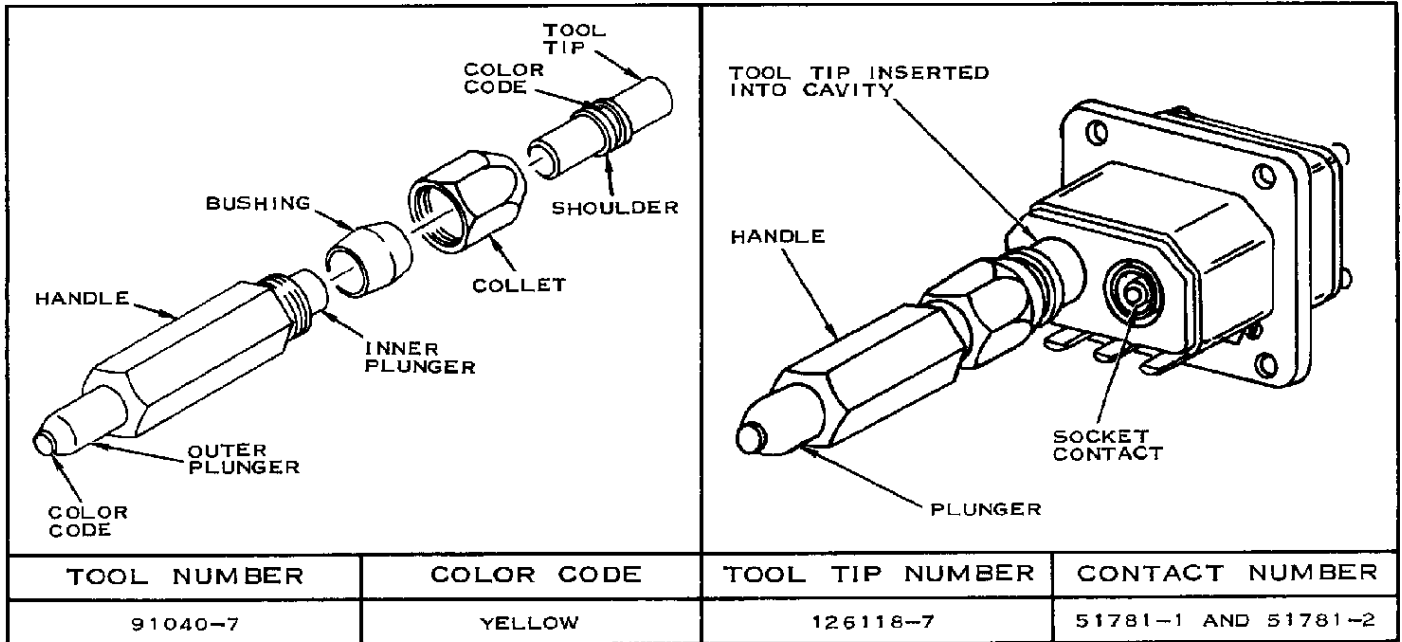

FIGURE 1

1. INTRODUCTION

We recommend the A-MP Extraction Tool 91040-7 for removing the COAXICON Socket Contacts listed in Figure 1. This tool is color coded for easy identification.

When replacement of the tool tip is required, order it by the number specified in the chart.

2. DESCRIPTION

This tool is designed with a stationary handle and tool tip which contains a spring loaded plunger. When the tool is aligned, the outer plunger is depressed, pushing the inner plunger against the contact and releasing it.

3. CONTACT EXTRACTION

Extract the contact as follows:

1. Center the tool tip over the contact to be extracted.
2. Firmly grip the handle and push the tool tip into the cavity as far as it will go. Be sure you hold the tool perpendicular to the connector. This will prevent damage to both the contact and tool tip.
3. Depress the plunger to back the contact out of the cavity.

4. Pull the contact from the rear of the connector.

4. TOOL TIP REPLACEMENT

Replace the tool tip as follows:

1. Secure the tool handle with a clamp or a suitable hand tool.
2. Using a wrench, loosen the collet by turning it counterclockwise.
3. Lift the tool tip out of the tool.
4. Place the new tip over the plunger. Now position the shoulder of the tip on the bushing inside the collet.
5. Turn the collet clockwise until it is hand tight. Using a wrench, tighten the collet an additional one/eighth turn.

CAUTION

Be sure you insert the proper end of the tip into the tool. If you should insert the wrong end, the tip will remain loose after the tightening procedure described in Step 5. **DO NOT ATTEMPT TO MECHANICALLY TIGHTEN THE COLLET MORE THAN ONE/EIGHTH TURN.**

★ TRADEMARK OF AMP INCORPORATED

© 1969 by AMP Incorporated. All international rights reserved. A-MP products covered by U.S. and foreign patents and/or patents pending.