*Figure 1*

1. INTRODUCTION

These extraction tools are designed to remove AMP* .156 MATE-N-LOK pin (using Tool 691458-1) and socket (using Tool 691458-2) contacts from their housings. Read these instructions thoroughly before attempting to remove any contacts.

2. DESCRIPTION (Figure 1)

The extraction tool consists of a sleeve and push rod button mounted to a handle. When correctly inserted into the housing contact cavity, the tool sleeve depresses the contact locking lance and the push rod button is used to eject the contact, permitting the contact to be removed from the back of the housing.

3. EXTRACTION PROCEDURE (Figure 2)

1. Push in and firmly hold the wire of the contact to be removed. This will disengage the locking lance from the groove in the connector.
2. Holding the tool handle, place the sleeve of the tool over the end of the contact on the mating face of the housing. Rotating the tool slightly, push the sleeve straight into the cavity until it completely bottoms. Allow the push rod button to "back out" of the handle. The locking lance is now released.
3. While holding the extraction tool in position, depress push rod button. The contact will partially eject from the back of the housing.
4. Pull back on the wire. The wire and contact should easily pull out of the housing.

4. TOOL MAINTENANCE

It is recommended that the tool be inspected when you receive it and at regularly scheduled intervals. The tool is not repairable, and it should be replaced when it is worn or damaged. Store the extraction tool in a clean, dry place and clean the extraction tool with a soft, lint-free cloth.

Additional tools can be purchased from:

CUSTOMER SERVICE (38-35)
AMP INCORPORATED
PO BOX 3608
HARRISBURG PA 17105-3608

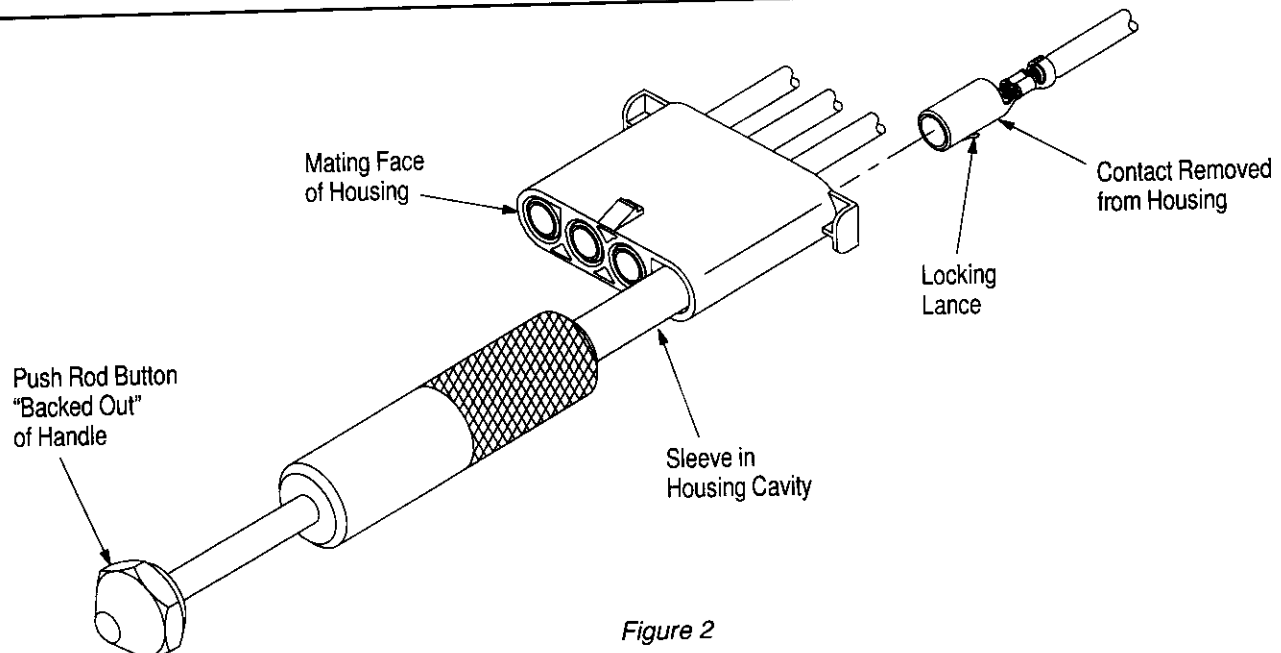
*Figure 2*