

Figure 1

1. INTRODUCTION

AMP* Extraction Tool 318845-1, shown in Figure 1, is designed to remove .140 contacts, listed in Figure 2, from AMP MATE-N-LOK* Connectors. Read these instructions thoroughly before attempting to remove any contacts.

STRIP		LOOSE PIECE	
PIN	SOCKET	PIN	SOCKET
61627-[]	61626-[]	350389-[]	350388-[]
350201-[]	350200-[]	350391-[]	350390-[]
770484-[]	—	—	—

Figure 2

2. DESCRIPTION (Figure 1)

The extraction tool consists of a spring-loaded metal tip with an integral plunger mounted to a plastic handle with an interlock lever. When the interlock lever is depressed, the plunger is held until the contact locking lances are depressed by the tip. After the lever is released, the plunger is released, permitting the contact to be pushed out the rear of the housing.

3. EXTRACTION PROCEDURE (Figure 3)

1. Determine the contact to be removed and grasp the wire attached to that contact.
2. Move the contact forward as far as possible by pushing the wire toward the housing.

NOTE

If pushing the wire by hand is difficult, use AMP Insertion Tool 91002-1.

3. Depress the extraction tool interlock lever and insert the tip of the tool into the contact cavity in the mating face of the housing. Make sure that the tip is completely bottomed in the cavity.

4. While holding the extraction tool in position and pulling back on the wire, release the interlock lever and push the tool handle forward. The wire and contact should pull out of the housing.

Push Wire Toward Housing
Before Engaging Tool Tip

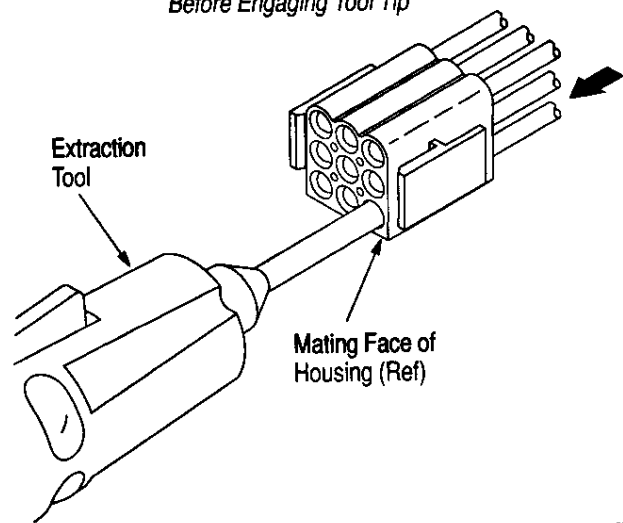

Figure 3

NOTE

Before using the contact again, reset the locking lances to their original positions. To obtain the correct setting dimensions for the locking lances, consult the AMP Customer Drawing covering the specific contact, or contact AMP engineering.

4. TOOL MAINTENANCE

It is recommended that the tool be inspected when you receive it and at regularly scheduled intervals. The tool is not repairable and should be replaced when it is worn or damaged. Store the extraction tool in a clean, dry place and clean the extraction tool with a soft, lint-free cloth.

Additional tools can be purchased from:

CUSTOMER SERVICE (38-25)
AMP INCORPORATED
PO BOX 3608
HARRISBURG PA 17105-3608