

THIS COPY IS PROVIDED ON A RESTRICTED BASIS AND IS NOT TO BE USED IN ANY WAY DETRIMENTAL TO THE INTERESTS OF PANDUIT CORP.

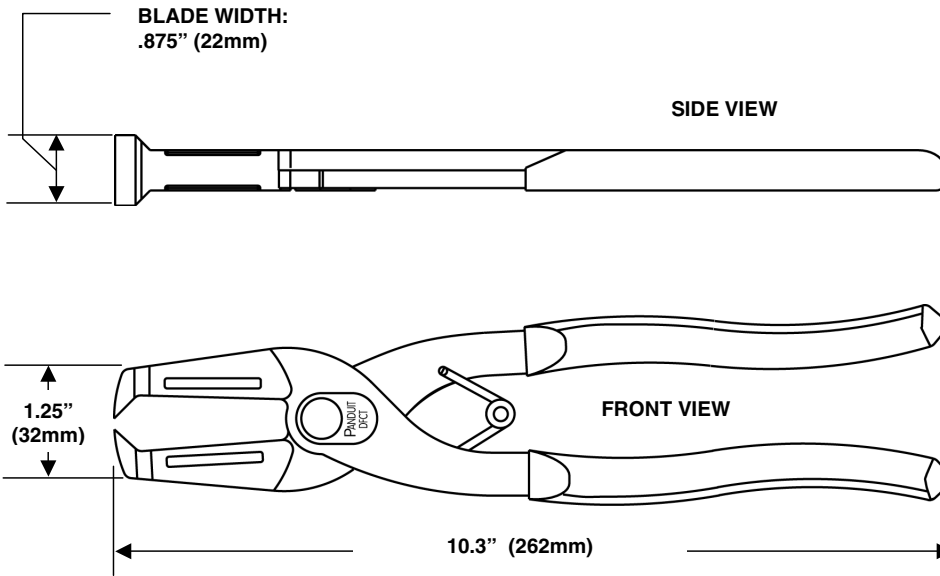

NOTES:

- Cuts *PANDUCT* Wide Finger Wiring Duct
- Also removes NR1 Nylon Rivets
- Spring open handles
- Heavy duty steel construction

WEIGHT: 1.09 lb./ea.
(495 gm./ea.)

DIMENSIONS ARE FOR REFERENCE ONLY

F:/wrkgrp/rvusers/engdocsnew/custdwgs/
WD24740A01_02 DFCT CD.doc

											CORP. TINLEY PARK, ILLINOIS	
									TOOL * DFCT			
									DUCT FINGER CUTTING TOOL			
						UNLESS OTHERWISE SPECIFIED, DIMENSIONAL TOLERANCES ARE:			UNLESS OTHERWISE SPECIFIED, ALL DIMENSIONS ARE GIVEN IN INCHES, THIRD ANGLE PROJECTION.			
02	3-23-05	BLR	MBR	ADD WIDE FINGER DUCT; SIDE VIEW W/DIM.	4153	--	DLWE		(.x) ± ---	(.xxx) ± ---		
01	6-30-03	BLR	ABJ	REMOVE DUCT TYPES	4092	--	DLWE		DRAWN BY: BLR	MATL: -----	SCALE NONE	
00	6-25-03	BLR	ABJ	RELEASED	4092	--	DLWE		DATE: 6-25-03		DRAWING NO. WD24740A01	
REV	DATE	BY	CHK'D	DESCRIPTION	ECN	-R	CUST	SUP	CHK'D: ABJ		DWG A SIZE	