

TERMINATING MODULE	MODULAR PLUG		CABLE			
	CATEGORY	PN	TYPE	WIRE INSULATION DIA RANGE	OUTSIDE DIA RANGE	WIRE SIZE RANGE (AWG)
791804-1	5e (EMT)	336330-[ ] 336352-[ ]	UTP● or FTP□ Stranded	0.80-1.0 mm [.031-.039 in.]	5.0-6.0 mm [.197-.236 in.]	26-24
	6	1375202-[ ]	UTP Stranded	0.89-1.09 mm [.035-.043 in.]	5.0-6.0 mm [.197-.236 in.]	
		1711345-[ ]	PiMF◇ Stranded			
		1372504-[ ]	UTP or FTP Solid			24-23
791804-2	5e (EMT)	336349-1	UTP or FTP Stranded	0.80-1.0 mm [.031-.039 in.]	5.0-6.0 mm [.197-.236 in.]	26-24
791804-3	5e (EMT)	336462-[ ] 336643-[ ]	UTP or FTP Stranded	0.80-1.0 mm [.031-.039 in.]	6.0-7.0 mm [.236-.276 in.]	26-24
	6	1479184-[ ]	UTP Stranded	0.89-1.09 mm [.035-.043 in.]		
		1711346-[ ]	PiMF Stranded	0.89-1.09 mm [.035-.043 in.]		
		1479185-[ ]	UTP or FTP Solid			24-23
791804-4	5e (EMT)	1711413-[ ]	UTP or FTP Stranded	0.80-1.0 mm [.031-.039 in.]	4.7-5.3 mm [.185-.208 in.]	26-24
	6	1933441-[ ]	UTP Stranded	0.89-1.09 mm [.035-.043 in.]		26-24
		1933442-[ ]	UTP Solid			24-23

- ElectroMagnetic Technology
- Unshielded Twisted Pair

Figure 1

- Foil-Wrapped Shielded Twisted Pair
- ◇ Pairs in Metal Foil

**NOTE**



All numerical values are in metric units [with U.S. customary units in brackets]. Dimensions are in millimeters [and inches]. Figures are not drawn to scale.

## 1. INTRODUCTION

Terminating Modules 791804-[ ] are designed to be used with Modular Plug Dual Terminators 1320840-[ ] or 856195-6. This combination terminates each modular plug listed in Figure 1 to create a cable assembly and tests it for electrical circuit continuity.

Read these instructions completely before using the module.

Reasons for reissue of this instruction sheet are provided in Section 9, REVISION SUMMARY.

When reading this document, pay particular attention to **DANGER** and **CAUTION** statements.

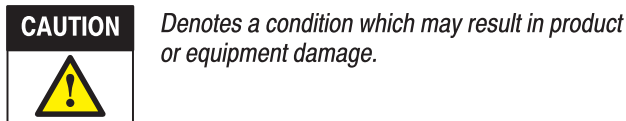
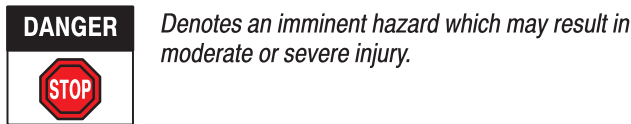

## 2. DESCRIPTION

These modules fit interchangeably into a modular plug dual terminator. Each module features dual nesting areas for positioning the modular plugs, inserters for terminating the contacts, and stuffers for terminating the primary and secondary strain reliefs. Since each feature is independently adjustable, crimp heights are easily adjusted to meet International Electrotechnical Commission (IEC) specifications.

Each terminator consists of a pneumatic power unit, a automatic circuit tester with cable hook-up and

ground, and an AC/DC converter. The tester can be set to test specific modular plug sizes and contact arrangements. Test results are signaled by a beeper; specific information is displayed by means of a series of light-emitting diodes (LED) on the front panel of the tester. The noise level produced by the terminator varies between 82 and 87 dB at the operator position.

## 3. INSTALLATION

### 3.1. Terminating Module

1. Install Terminator 1320840-[ ] according to Customer Manual 409-10010, or install Terminator 856195-6 according to the documentation included with the terminator. Plug the base unit into:

TERMINATOR	SERVICE
1320840-1	115 Vac, 60Hz
1320840-2	230 Vac, 50Hz
856195-6	220 Vac, 50Hz

2. DISCONNECT the air supply.

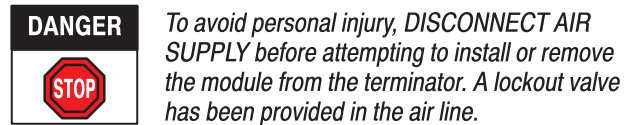

3. Remove the plastic guard from the module by removing four screws and two terminals from the limit switch (refer to the customer drawing for the module for location).
4. Connect the cable from the automatic circuit tester to the rear of the module, and tighten the screws to secure cable. Refer to Figure 2.

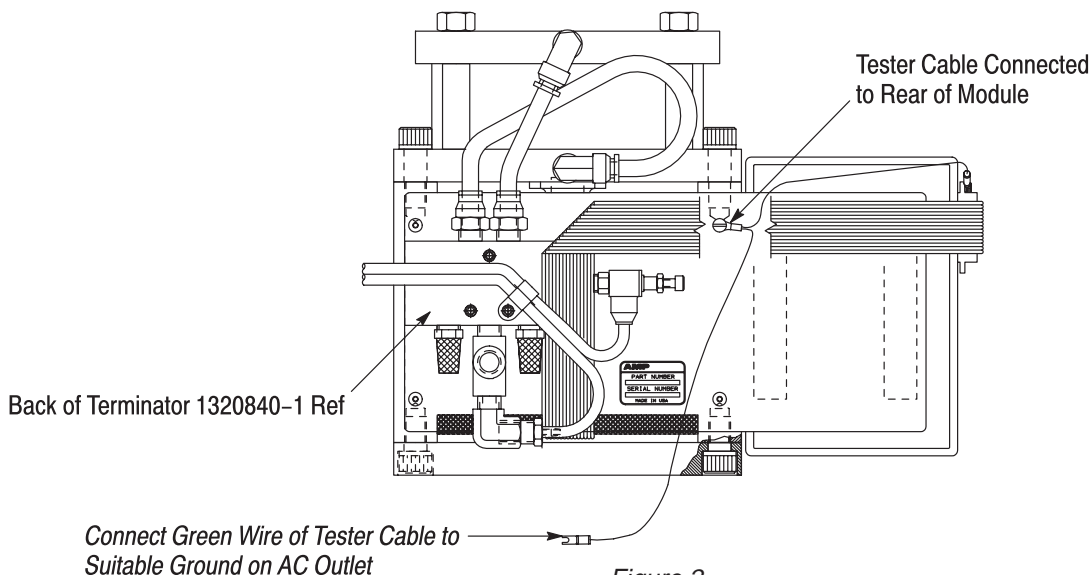

Figure 2

5. Check that the two single-wire terminations on the limit switch to the left of the tester cable (viewing from the rear of the module) are firmly connected to the limit switch at the top-most and bottom-most terminals (normally-closed position). Verify that the green wire of the tester cable is connected to the terminator and to a suitable ground on an AC outlet. Refer to Figure 2.

6. Position the module so that the T-slot at the top will slide onto the arm of the terminator so that the module rests on the base plate of the terminator. Tighten the screws at the bottom front of the module, securing the module to the base plate.

7. Re-connect the air supply to the terminator (regulated air supply range of 551 to 689 kPa [80 to 100 psi] at 0.47 liters/sec [1.0 scfm]).

8. Re-install the plastic guard onto the module. Run samples according to 409-10010 to inspect the crimp height of each modular plug. If necessary adjust the crimp height as described in Paragraph 3.1.

### 3.2. Tooling Adjustment

#### NOTE



Normally the module is adjusted prior to shipment, and little or no adjustment will be required by the customer. However, if wearable parts are replaced, a small amount of adjustment may be required.

Two setscrews are provided at each side of the ram head (at the top of the module) for adjustment purposes. The front setscrews allow adjustment of the hexagonal crimper. The rear setscrews allow adjustment of the contact inserter and secondary strain relief. If the contacts have the proper crimp height, the secondary strain relief will have the proper height, as well (by construction).

If adjustment is required to obtain proper crimp height, refer to Figure 3 and the applicable application specification, and proceed as follows:

1. Remove the module from the terminator by reversing the installation instructions provided in Paragraph 3.1.
2. Place the module on a horizontal, flat surface.
3. Check the clearance between the hexagonal crimper legs and the hexagonal anvil with a piece of thin paper. Clearance must be within the dimensions given in Figure 3. If adjustment is required, slightly loosen the the socket head cap screws at the front of the ram and the front locking setscrews at the front of the ram head. Then rotate the front setscrews to adjust the hexagonal crimper.

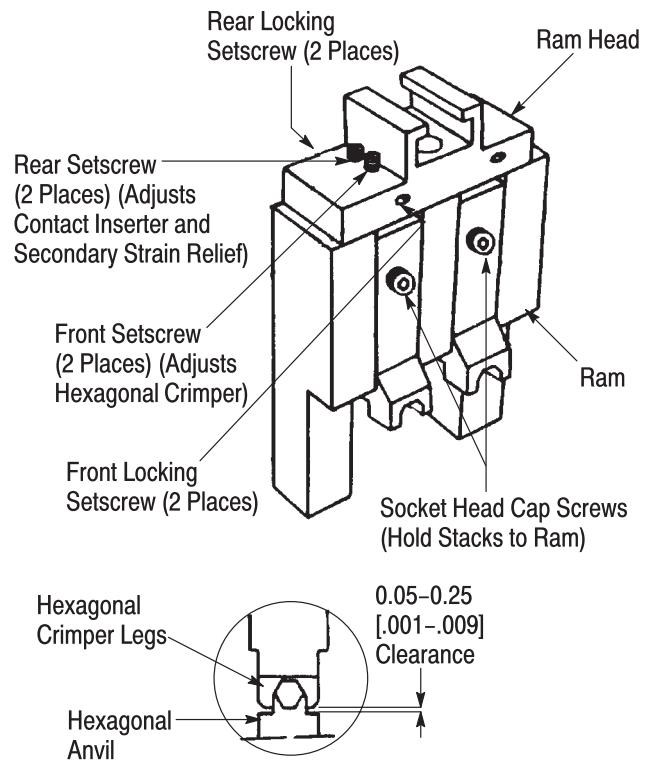

Figure 3

#### NOTE



A 360-degree rotation of the front setscrews makes a difference of approximately 0.8 [.032].

4. If the contact crimp height is still *not* correct, loosen the rear locking setscrews at the rear of the ram head. *Make sure* that the rear locking setscrews are loosened. Rotate the rear setscrews to adjust the crimp height (simultaneously adjusting the secondary strain relief). Rotate the screws *clockwise* to move the contact inserter downward.

#### NOTE



A 360-degree rotation of the rear setscrews makes a difference of approximately 0.8 [.032].

5. After adjustment has been performed, push the three parts at each side of the ram to the upper-most position, and tighten the socket head cap screws at the front of the ram. Re-position the ram on the module. Then re-install the module on the terminator as described in Paragraph 3.1.
6. If the hexagonal anvil has been moved or replaced, it may require some "in-out" adjustment as follows:
  - a. Remove the ram.
  - b. Loosen the button head cap screw on the hexagonal anvil. See Figure 4.

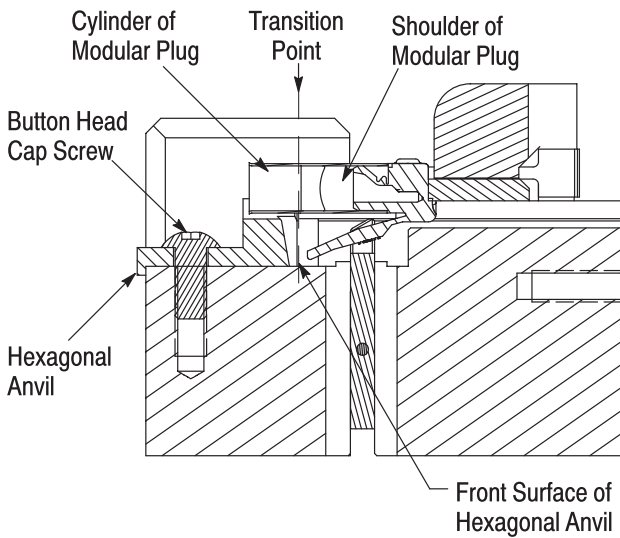

Figure 4

c. Place a modular plug (with the shield assembled, if applicable) on the hexagonal anvil.

**NOTE** *When the anvil is positioned properly, the front surface of the anvil is in the same vertical plane as the transition point between the modular plug cylinder and shoulder. See Figure 4.*

d. When the in-out position of the hexagonal anvil is adjusted, tighten the button head cap screw.

b. Place the 1:1/1:N switch in the appropriate position.

c. Set the wire position switches for all the contacts that will have wires to the "I" position. Set the switches for the contacts that are unused or open in the "O" position.

For crossed conductors:

a. Obtain a cable that fits the specifications required (crossovers, open positions, etc.). Insert, and fully latch, both modular plugs to the module nesting area with the modular plug release tab facing *downward*.

b. Turn the position selector switch to indicate the size of the modular plug being using.

**NOTE** *The 1:1/1:N switch and wire position switches are disabled when using the LEARN mode and can remain in any position.*

c. Press, and release the LEARN push button. The wire position LEDs will indicate a new pattern and a short tone will sound, indicating that the tester has successfully examined and stored the cable wiring pattern.

d. Hold the cable assembly release (of the module) down and remove the cable assembly from the nesting area. Turn the position selector switch to the LEARN position.

**3.3. Automatic Circuit Tester Setup** (Figure 5)

1. Plug the miniature plug of the AC/DC converter into the tester power inlet (top hole on the left side), and plug the base unit of the terminator into an outlet with the service specified in Paragraph 3.1. At power-up, the tester will respond with one long tone, followed by three short tones. The wire position LEDs will begin the "stand-by" LED pattern.

**NOTE** *The wire position LEDs blink on and off in a fixed "back-and-forth" sequence.*

2. Determine the wiring-to-modular plug relationship of the cables: 1:1, 1:N, or crossed conductors.

3. Set the tester switches in the following manner (see Figure 5).

For 1:1 or 1:N orientation:

a. Turn the position selector switch to indicate the total number of contacts in the modular plug.

**Automatic Circuit Tester Switches and LEDs**

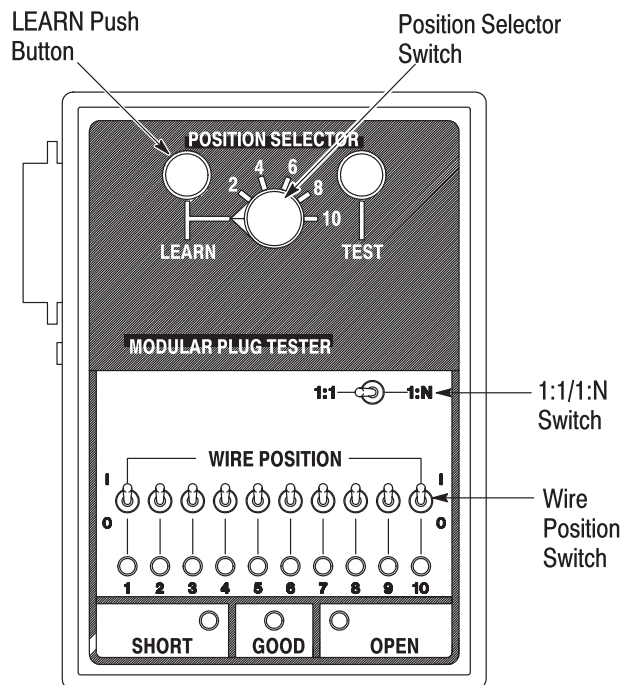

Figure 5



## 4. TERMINATING, TESTING, AND INSPECTING

### 4.1. Terminating and Testing Modular Plugs

1. Strip the cable insulation *outer jacket* within the dimension given in Figure 1. DO NOT strip the insulation from the individual conductors. Refer to the applicable application specification for proper stripping requirements:

114-13035 (Category 6 Shielded and Unshielded)

114-22008 (Category 5e EMT)

114-93006 (Category 6 Shielded)

2. Insert the stripped cable into the modular plugs, and insert the cable and modular plugs into the module nesting area. Ensure the following:

— the cable conductors are oriented to the appropriate contact slots before inserting the conductors into the modular plugs

— the cable conductors are bottomed in the contact slots of the modular plugs, and that they remain bottomed throughout the cycling of the terminator

— the modular plugs bottom in the module nesting area (the modular plug release tabs MUST snap firmly into place)

3. Cycle the terminator. When termination is complete, the tester will automatically examine the cable assembly and respond with either a short tone or a long tone. Refer to Figure 6. After the cable assembly is tested, hold the cable assembly release down, and remove the cable assembly from the module.



**CAUTION** Removing the cable assembly *BEFORE* a tone has sounded may cause good terminations to test as failures.



**NOTE** Any coupled cable assembly may be tested or re-tested inserting and latching the modular plugs into the nesting area and pressing the **TEST** push button.

### 4.2. Inspecting Cable Assemblies

Inspect the crimp on each modular plug using an indicator with a 0.25 [.010] diameter needle-point probe. See the applicable application specification (referenced in Paragraph 4.1) for crimp height and other terminated modular plug criteria.

Problems associated with *bad* cable assemblies should be recorded to aid in troubleshooting. Check for the source of recurring problems in the following order:

1. Check the settings against the test cable.

2. Make sure the correct combination of cable and modular plugs is being terminated.

3. Check the crimp height and strain relief settings, and, if necessary, make the corresponding adjustments to the module.

4. Inspect the spring plungers to make sure that they are all correctly resting on the contact probes.

5. Inspect, and replace any defective mechanical tooling parts. Refer to Section 6. If the problem cannot be resolved, call the TOOLING ASSISTANCE CENTER at the number at the bottom of page 1.

## 5. MAINTENANCE AND INSPECTION

These instructions have been established to ensure the continued quality and reliability of the module. It is recommended that each module be inspected immediately upon arrival to ensure that the module has not been damaged during shipping and at regularly scheduled intervals.

### 5.1. Daily Maintenance

It is recommended that each operator of the module be aware of and responsible for the following steps of daily maintenance:

1. At the end of each shift, clean the foreign particles from the module using a soft, clean, lint-free cloth or brush. Make sure that the contact inserters and strain relief stuffers are secured in place. Check the area under the base plate for foreign matter and debris.

2. Inspect the module for secure engagement of the connectors and tester cable to the module and of the wires to the limit switch at the left rear of the module.

3. Lubricate the module ram, if necessary, with a THIN coat of high-pressure grease. DO NOT lubricate excessively. Store the module in a clean, dry place.



**CAUTION** Make sure to keep the terminating areas of the stuffers and nesting areas especially clean. DO NOT oil or grease the terminating areas of the stuffers or the contact slides.

### 5.2. Periodic Inspection

Quality control personnel should perform regular inspections, record the results, and keep a record of inspections with the module, or supply the records to personnel responsible for the module.

It is recommended that inspection procedures be performed at least once a month. Work environment, company standards, or amount of module use may dictate more frequent inspections.



Failure to perform periodic inspection and cleaning can cause the module to make defective modular plug terminations leading to discontinuities on individual wire circuits.

## 6. TROUBLESHOOTING

For solutions to problems not mentioned in Figure 7, call the TOOLING ASSISTANCE CENTER at the number at the bottom of page 1.

TESTING SUMMARY			
ORIENTATION	TEST	CONDITION	TEST INDICATORS
1:1 and 1:N	The tester checks for open conductors.	One or more open conductors.	A <i>long</i> tone will sound and the OPEN LED will light. The Wire Position LEDs will also light, corresponding to the open conductors of the modular plug located in the <u>right-hand</u> nest. <b>Note:</b> If “opens” are found, the tester abandons further testing, therefore shorts that may have also been present will not be indicated.
	If there are no open conductors, the tester checks for short circuits.	The cable assembly has two or more shorted conductors.	A <i>long</i> tone will sound and the SHORT LED will light. The Wire Position LEDs will also light, corresponding to the shorted conductors of the modular plug located in the <u>right-hand</u> nest.
	No “opens” or “shorts” are found.	The cable assembly is considered good.	The tester will sound a <i>short</i> tone and the GOOD LED will light.
Crossed Conductors	With the position selector switch in the LEARN position, the tester compares the cable assembly against a “learned” cable pattern. When a cable assembly has a “learned” cable pattern, open conductors, as well as crossed conductors, are noted.	Contacts that were learned as “open” are found to have continuity to other conductors in the cable assembly.	The tester will sound a <i>long</i> tone, light <u>both</u> the OPEN and SHORT LEDs, and light the Wire Position LEDs corresponding to the connected conductors of the modular plug located in the right-hand side of the nest.
	If there are no connections where there should be opens, the tester will conduct the “opens” test.	The cable assembly has one or more open conductors.	The tester will sound a <i>long</i> tone, the OPEN LED will light, and the Wire Position LEDs will light, corresponding to the open conductors of the modular plug located in the <u>right-hand</u> side of the nest.
	If there are no opens present the tester performs the “shorts” test.	The cable assembly has two or more shorted conductors.	The tester will sound a <i>long</i> tone, the SHORT LED will light, and the Wire Position LEDs will light, corresponding to the open conductors of the modular plug located in the <u>right-hand</u> side of the nest.
	The cable assembly passes all three tests.	The cable assembly is considered good.	The tester will sound a <i>short</i> tone and the GOOD LED will light.

Figure 6

TROUBLESHOOTING		
PROBLEM	CAUSE	SOLUTION
Tester LEDs do not display the “standby” pattern, and the tester is unresponsive in general.	Power to the tester has been interrupted.	<ol style="list-style-type: none"> <li>1. Make sure that the miniature plug of the AC/DC adaptor is fully inserted into the jack located through the top hole on the left-hand side of the tester.</li> <li>2. Remove the miniature plug from the tester. With the base unit still plugged into the power outlet, check the voltage output of the adaptor. A voltmeter should read between 9 and 11 volts DC—outer ring of the modular plug positive, center hole negative. If the proper voltage is not present, check the wall outlet for proper AC line voltage. If the wall outlet voltage is adequate, replace the adaptor.</li> </ol>
The tester falls dormant (no “standby” LED pattern) for approximately 1 to 2 seconds, then starts blinking all LEDs and sounding a short tone, once every second.	<ol style="list-style-type: none"> <li>1. The ribbon cable from the tester to the module is loose or faulty.</li> <li>2. The two wires from the module printed circuit board to the limit switch are loose or connected incorrectly.</li> <li>3. The limit switch is faulty.</li> <li>4. The terminator ram has been “bottomed” for more than 2 seconds.</li> </ol>	<ol style="list-style-type: none"> <li>1. Check the ribbon cable for tight connections, both at the tester and at the module printed circuit board. Tighten connections, if necessary. Replace, if necessary.</li> <li>2. Check the wire connections at the terminals of the limit switch for tightness and for correct position: “COM” and “NC” terminals.</li> <li>3. Check the limit switch with a continuity meter between the COM and the NC terminals. These terminals should show <i>continuity</i> when the switch is not actuated, and <i>open</i> when the switch is actuated. Replace the switch if necessary.</li> <li>4. The operator’s foot must be removed from the pedal after cycling the terminator; otherwise, the ram will remain in the bottomed position.</li> </ol>
While “learning” a cable pattern or testing a cable assembly against a “learned” cable pattern, the tester flashes all LEDs 5 times, and then resumes the “standby” LED pattern.	The memory component that stores the “learned” cable pattern is faulty.	Return the tester for repair.

Figure 7

## 7. REPLACEMENT AND REPAIR

Refer to the engineering documentation package shipped with the module for a list of recommended spare parts. The parts are customer replaceable. Order replaceable parts through your representative, or call 1-800-526-5142, or send a facsimile of your purchase order to 1-717-986-7605, or write to:

CUSTOMER SERVICE (038-035)  
 TYCO ELECTRONICS CORPORATION  
 PO BOX 3608  
 HARRISBURG PA 17105-3608

For customer repair service, call 1-800-526-5136.

## 8. RoHS INFORMATION

Information on the presence and location of any substances subject to restriction on hazardous substances (RoHS) can be found at the following website (click on “Find Compliance Status,” and enter the terminating module part number):

<http://www.tycoelectronics.com/customersupport/rohs-supportcenter/>

## 9. REVISION SUMMARY

Revisions to this instruction sheet include:

- Added Section 8