

Figure 1

## 1. INTRODUCTION

AMP\* Mass Insertion Terminating Head 58644-1, shown in Figure 1, is designed to terminate MTA 100 feed-through receptacle connectors (positions 2 through 12) onto discrete wire sizes 28 through 22 AWG with a maximum insulation diameter of 1.27 mm [.050 in.]. Refer to Figure 2 for reference connector part numbers.

**NOTE**

*This head is designed to terminate one connector at a time.*

**NOTE**

*A complete list of current connector part numbers cannot be maintained on this document. For all part numbers and their description, refer to Catalog 82056 or contact Product Information at the number at the bottom of this page.*

The head is used with Pistol Grip Manual Handle Assembly 58074-1. For terminating head installation procedures, and setup and operation of the handle assembly, refer to Instruction Sheet 408-6790. Read this and the referenced material before terminating any connectors.

**NOTE**

*Dimensions on this sheet are in metric units [with U.S. customary units in brackets]. Figures are not drawn to scale.*

Reasons for reissue are provided in Section 8, REVISION SUMMARY.

## 2. DESCRIPTION (Figure 1)

The terminating head, when properly installed onto the handle assembly, serves as a guide for the connector during termination.

Features of the head and their functions are as follows:

**Wire Inserter**—supports each wire in individual wire slots so that, during the insertion cycle, the wire forced into the two-slotted beam of the contact.

**Wire Guide**—holds the wires in position over the wire inserter.

**Ram**—locates and holds the connector while pushing it down onto the wires.

**Locating Pawl**—holds connector in proper alignment to the wire inserter.

**Push Rod**—used to push the terminated connector past the locating pawl for removal.

**Insertion Rod Adjuster**—is a piston for the ram and regulates the travel of the inserted wires.

Each wire is terminated in a connector contact using the insulation displacement technique (a terminating technique which inserts unstripped wire into a slotted contact beam to form a reliable electrical connection between the wire and the contact). Contact termination is complete when the handle assembly is actuated.

WIRE SIZE (AWG)	MTA 100 FEED-THROUGH RECEPTACLE CONNECTORS (With Locking Ramp)*		
	COLOR CODE	WITH POLARIZING TABS	WITHOUT POLARIZING TABS
22	Red	644540	640620
24	White	644563	640621
26	Blue	644564	640622
28	Green	644565	640623

\* Dash numbers indicate number of contact positions (-2 through -12 are applicable for this terminating head).

Figure 2

### 3. SETUP

#### 3.1. Installing Head

The head can be installed onto the handle assembly and used as a hand-held tool, or several tools can be mounted onto a board to be used as a low-level harness board fixture.

The board must have two 6.36-mm [.250-in.] holes spaced 44.45 mm [1.75 in.] apart for each head. Secure each head with screws. See Figure 3.

**NOTE** *The handle assembly is not quick to install onto the head; therefore, each head should have its own handle assembly.*

#### Installing Head As Harness Board Fixture

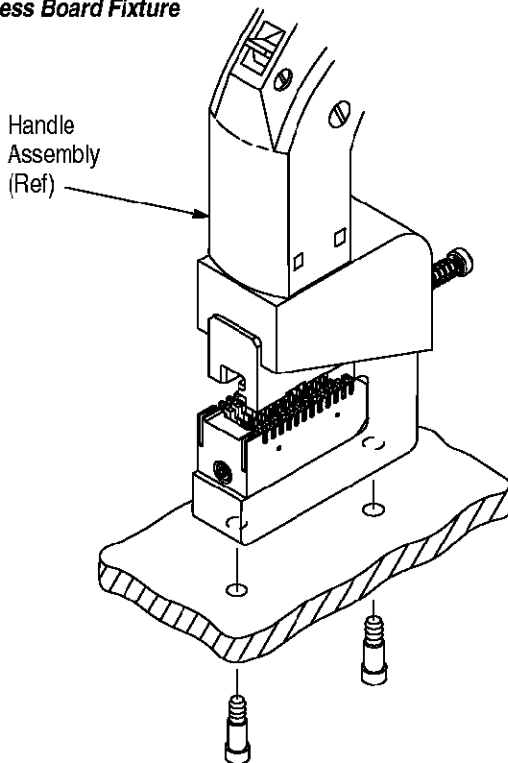

Figure 3

#### 3.2. Test Termination

At least one test termination should be performed and inspected before starting production. Determine the wire size and select the appropriate color-coded connector.

1. Using a small knife, cut off the wire retainers (strain relief) from both sides of the test connector. See Figure 4.

**NOTE** *Wire retainers must be removed from test connectors to provide a clear view for inspection—do NOT use test connectors for production applications.*

2. Terminate the test connector according to Section 4 and inspect the connector following the requirements in Step 6. Make any insertion depth adjustments to the terminating head according to Section 5 before starting production.

### 4. TERMINATING PROCEDURE

1. Starting with the wire slot closest to the head frame, push one wire into one slot for each contact position of the connector being terminated. See Figure 5.
2. Insert the connector into the ram with the contact insulation barrels facing the wire slots.
3. Using a screwdriver (or equivalent), push the connector into the ram until the connector touches the surface of the frame. Refer to Figure 5.

**NOTE** *To ensure proper alignment in the head, all connector positions must touch the surface of the head frame.*

4. Actuate the handle assembly according to the instructions packaged with the handle assembly.

**CAUTION** *After the ram completes the stroke, no wires should be left in the wire slots. If any wires are still in the slots, pull them up and out of the slots before continuing.*

5. Depress the push rod to move the terminated connector beyond the locating pawl in the ram. Then grip the wires on both sides of the connector and carefully guide the connector out of the ram.

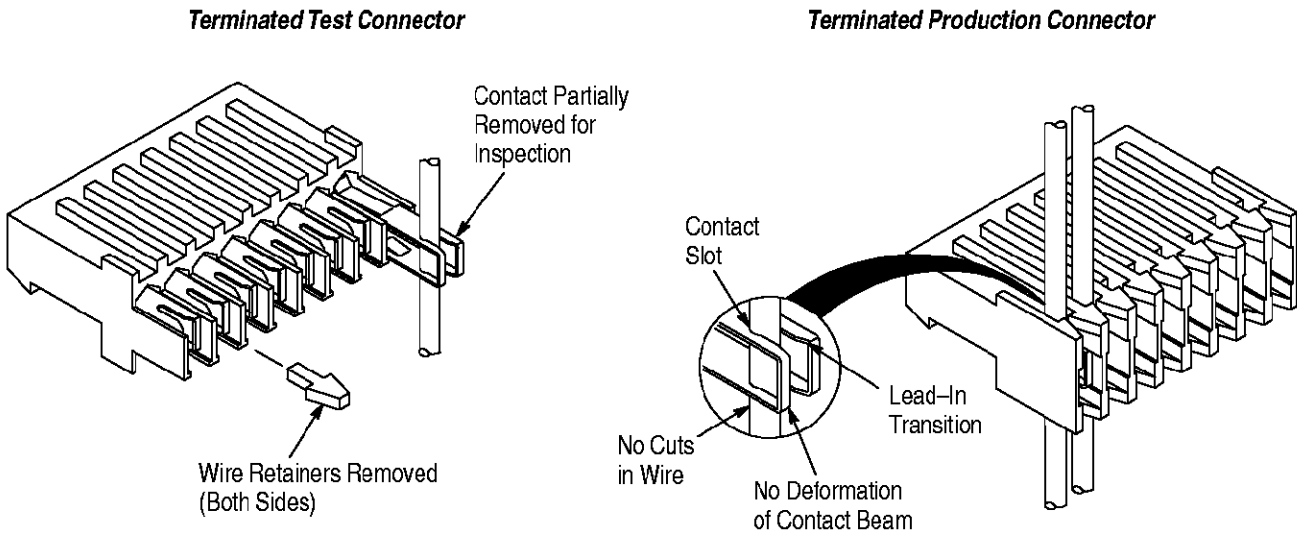

Figure 4

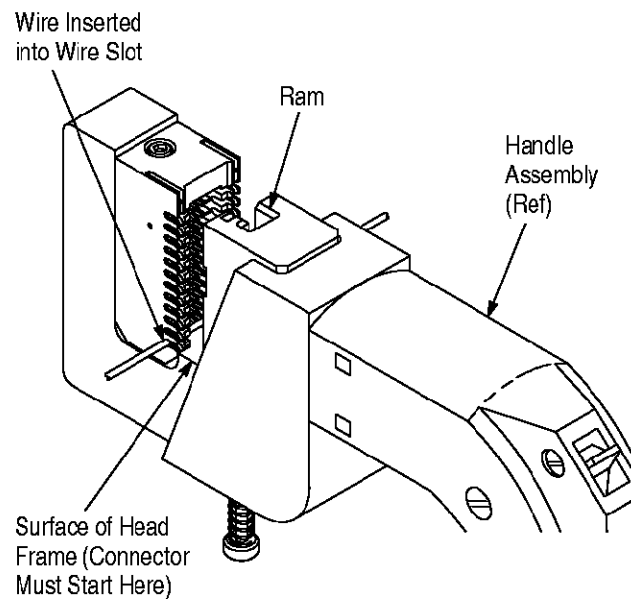

Figure 5

6. Refer to Figure 4 and visually inspect the connector according to the following. If wire insertion depth is found to be improper, refer to Section 5 for head adjustments.

**CAUTION**

Wire insulation tends to return to form after being compressed. It is important to inspect the connector within five minutes of termination; otherwise, an improper inspection may result.

- Conductors are terminated past the lead-in transition and halfway into the contact slot.

- Wires are not bottomed in contact slots.
- Wire insulation is not nicked or cut in any areas except in the contact slots.
- Contact beams are not deformed. If damage is evident, replace the damaged contact according to the instructions packaged with the connector.
- Wire extends below the connector wire retainers.

**NOTE**

For detailed inspection information, refer to Application Specification 114-1019.

**5. INSERTION DEPTH ADJUSTMENT**

The terminating head is preset for nominal wire insertion depth; however, it may be necessary to make adjustments to the head, due to the wide range of cable sizes used, as follows:

1. Remove the head from the handle assembly.
2. If the wires are too deep in the contact slots, turn the insertion rod adjuster *clockwise*. A  $\frac{1}{6}$ -revolution will decrease the wire insertion depth by approximately 0.20 mm [.008 in.]. If the wires are not deep enough in the contact slots, turn the adjuster *counterclockwise*. A  $\frac{1}{6}$ -revolution will increase the wire insertion depth by approximately 0.20 mm [.008 in.]. See Figure 6.
3. Install the head onto the handle assembly; then terminate and inspect a test connector.
4. Repeat the adjustment as necessary until proper wire insertion depth is obtained. DO NOT use a tighter setting than required.

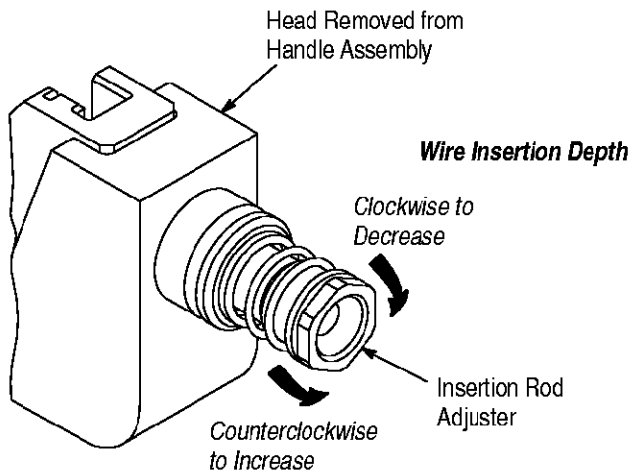

Figure 6

## 6. MAINTENANCE AND INSPECTION

Tyco Electronics recommends that a maintenance and inspection program be performed periodically to ensure dependable and uniform terminations.

### 6.1. Daily Maintenance

1. Remove dust, moisture, and other contaminants with a clean, soft brush or a soft, lint-free cloth. Do NOT use objects that could damage the head.
2. Make sure that all pins, rings, and other components are in place and secure.
3. When head is not in use, store it in a clean, dry area.

### 6.2. Periodic Inspection

Regular inspections should be performed by quality control personnel. Though recommendations call for at least one inspection a month, the frequency should

be based on amount of use, working conditions, operator training and skill, and your established company policies.

1. Remove all lubrication and accumulated film by immersing the head in a suitable commercial degreaser that will not affect paint or plastic.
2. Make certain all components are in place. If replacements are necessary, refer to Section 7.
3. Check all bearing surfaces for wear. Replace worn or damaged parts.
4. Inspect the head for flattened, chipped, or broken surfaces. Replace worn or damaged parts.

## 7. REPLACEMENT AND REPAIR

Replacement parts are listed in Figure 7. A complete inventory can be stocked and controlled to prevent lost time when replacement of parts is necessary. Order replacement parts through your Tyco representative, or call 1-800-526-5142, or send a facsimile of your purchase order to 1-717-986-7605, or write to:

CUSTOMER SERVICE (38-35)  
TYCO ELECTRONICS CORPORATION  
PO BOX 3608  
HARRISBURG PA 17105-3608

For tool repair service, please contact a Tyco representative at 1-800-526-5136.

## 8. REVISION SUMMARY

Since the previous release of this sheet, the following changes were made per EC 0990-1288-00:

- Updated document to corporate requirements
- Changed address in Section 7, REPLACEMENT AND REPAIR
- Changed part number 22279-1 to 23147-3 in Figure 7

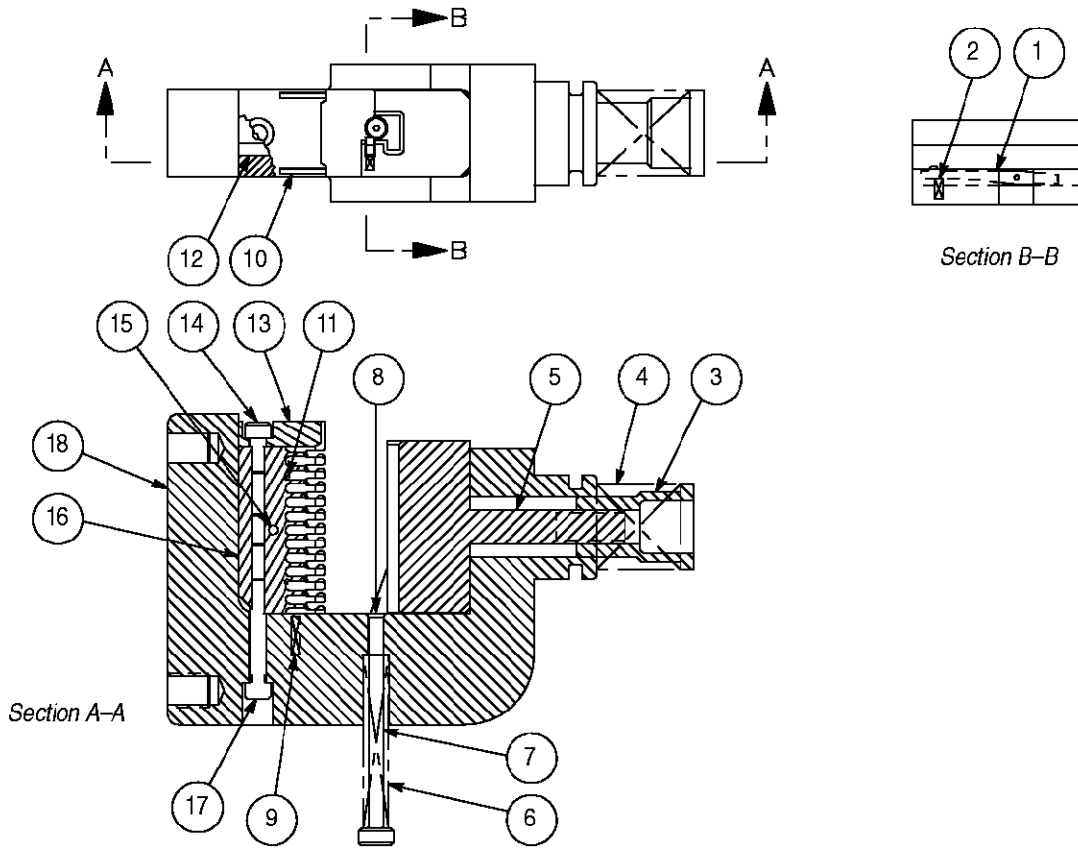

ITEM	PART NUMBER	DESCRIPTION	QTY PER HEAD
1	904092-1	PAWL, Locating	1
2	23147-3	SPRING, Compression	1
3	312149-1	ADJUSTER, Rod Insertion	1
4	22488-5	SPRING, Compression	1
5	904087-1	RAM	1
6	2-22279-5	SPRING, Compression	1
7	904093-1	ROD, Push	1
8	21003-1	SCREW, Flat Head Cap, 0-80 x .12	1
9	1-23147-2	SPRING, Compression	2
10	904086-1	CLAMP, Wire Guide	2
11	21949-1	PIN, Spiral Wrapped	5
12	904129-1	BLOCK, Wire	2
13	904085-1	GUIDE, Wire	1
14	1-21000-4	SCREW, Socket Head Cap, 4-40 x .38	1
15	21028-2	PIN, Slotted Spring	1
16	904084-1	BLOCK, Inserter	1
17	1-21000-7	SCREW, Socket Head Cap, 4-40 x .75	1
18	904083-1	HEAD	1

Figure 7