

AMPAMP INCORPORATED
Harrisburg, Pa. 17105AMP ★ APPLICATOR 220144-1
AND DIES 220155
(For AMP Coaxial Ribbon Cable Receptacles)

Instruction Sheet

IS 9071

RELEASED 12.10.84

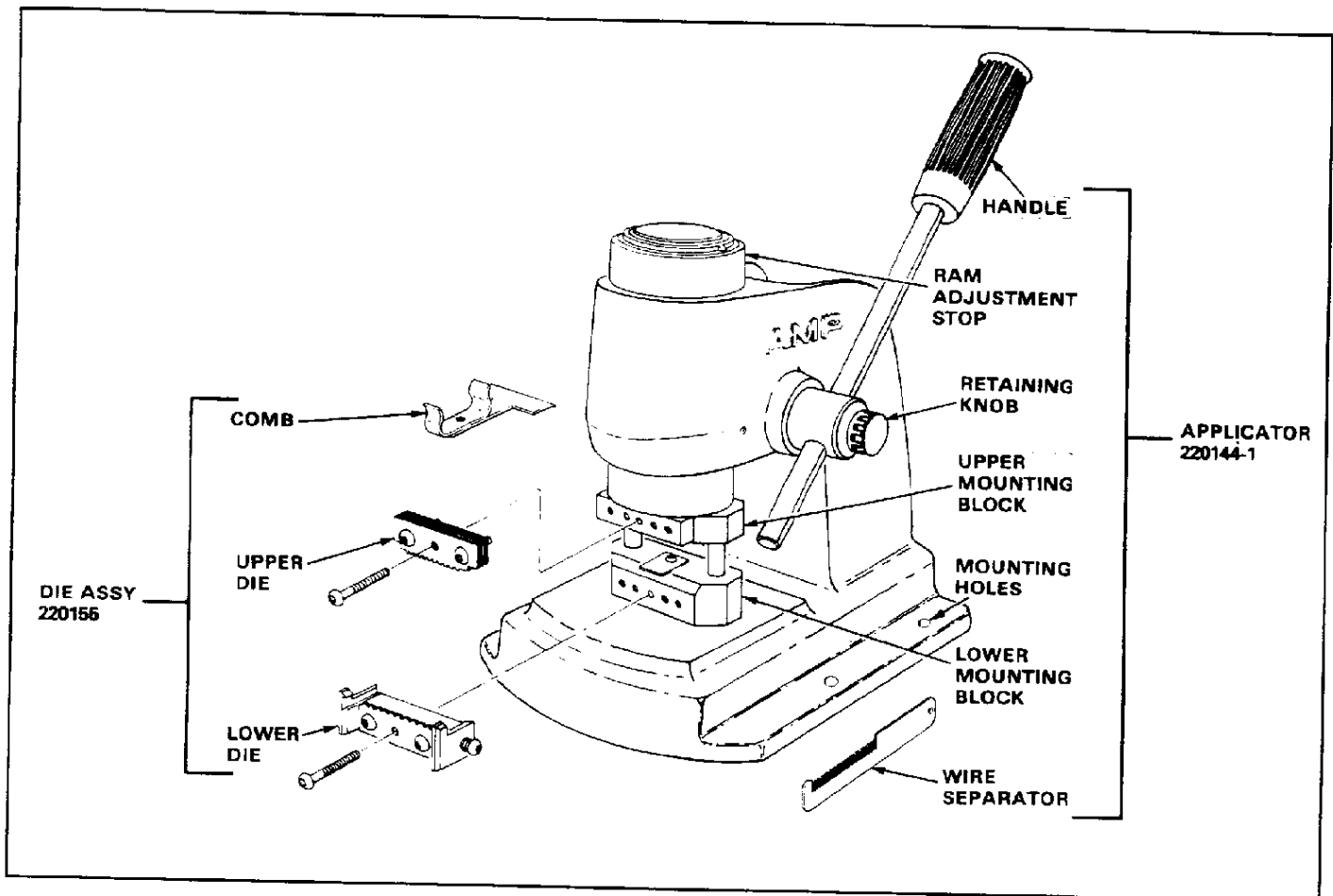

Fig. 1

1. INTRODUCTION

AMP Applicator 220144-1, shown in Figure 1, is designed for use with AMP Crimping Die Assemblies, Base No. 220155 (see Figure 2 for individual dash numbers). The tooling terminates AMP Coaxial Ribbon Cable with AMP Coaxial Ribbon Cable Receptacles (see Figure 2) having up to and including 25 positions. This instruction sheet (IS) gives application and maintenance instructions for the applicator and dies. Read these instructions thoroughly before terminating any cables.

Refer to *IS 2577*, packaged with the receptacles, for description, selection data, cable preparation, and assembly of the receptacles.

NOTE

All dimensions presented on this instruction sheet are in inches.

2. DESCRIPTION (Figure 1)

The applicator and dies are designed to insert a maximum of 50 ribbon cable contact posts (25

ground wires, 25 conductor wires) at a time.

A. Applicator 220144-1

Applicator 220144-1 consists of a frame (cast) assembly with upper and lower mounting blocks designed to hold the upper and lower subassemblies of Die Assembly 220155. An adjustable handle and retaining knob, removable for packaging and storage when the frame assembly is not in use, also accompany the applicator.

Other features of the applicator are:

- Four mounting holes, provided for securing the applicator to a workbench.
- Ram adjustment stop, factory-set, to ensure proper, consistent bottoming of the ram.
- Wire separator, Part No. 310573, supplied with the applicator and used to bend the center conductors away from the ground conductors during cable preparation (see *IS 2577*).

*Trademark of AMP Incorporated

STANDARD	RECEPTACLE KITS (Ref)		NO. OF POSN	TOOLING	
	WITH MOUNTING FLANGES	POLARIZATION AND DETENT		DIE ASSY	APPLICATOR
226634-1	226651-4	226733-1	4	220155-4	220144-1
226633-1	226651-5	226733-2	5	-5	
226530-1	226651-6	226733-3	6	-6	
226552-1	226651-7	226733-4	7	-7	
226553-1	226651-8	226733-5	8	-8	
226554-1	226651-9	226733-6	9	-9	
226476-2	2-226651-7	2-226733-4	10	1- -0	
226476-1	1-226651-0	226733-7	10	1- -0	
226477-1	1-226651-3	1-226733-0	13	1- -3	
226478-1	1-226651-7	1-226733-4	17	1- -7	
226305-1	2-226651-0	1-226733-7	20	2- -0	
226479-1	2-226651-5	2-226733-2	25	2- -5	

Fig. 2

B. Die Assembly 220155 (Figure 3)

Each die assembly consists of an upper subassembly (upper die) and a locator subassembly (lower die). The lower die, with spring-loaded locators, spacer, housing stop, and holding screws, holds the receptacle housing in place. The upper die, a subassembly of stakers, spacers, holding screws, and snap rings, is attached to the manually powered ram. The upper die crimps the individual center conductors and ground wires of the ribbon cable to the contacts of the receptacle housing, using the technique of *insulation displacement*. Refer to the chart in Figure 2 for selection of the particular dash-number die assembly used in terminating the cable and connector.

NOTE

Dash numbers of die assemblies match the number of receptacle positions; eg, Die Assembly 220155-5 is used for a 5-position receptacle.

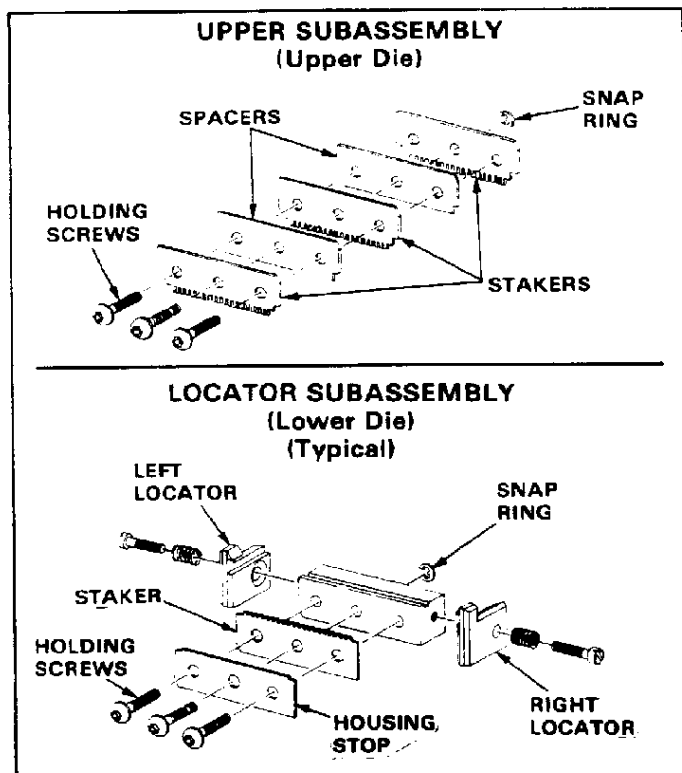

Fig. 3

Also supplied with the dies is a *comb*, used to align the wires with the individual contacts of the receptacle housing before termination.

3. APPLICATOR SETUP (Figure 1)

1. Unpack the applicator and dies, and wipe the protective film from all tooling — applicator, dies, wire separator (remove protective sheath), and comb. The protective film, if not removed, may adversely affect electrical terminations of the receptacle after it has been terminated to the ribbon cable.
2. Secure the applicator to a workbench by using suitable hardware through the four mounting holes.
3. Insert handle into holder until retaining knob engages one of the detents in the handle. (Length of handle varies according to the detent selected.)
4. Push handle backward to raise upper mounting block.
5. Position lower die on lower mounting block and tighten holding screws. See Figure 1.
6. *Locate* a receptacle housing of appropriate size on lower die subassembly: slip mating face of housing under spring and push housing toward applicator, pressing downward (Figure 4). *The spring-loaded locators will spread outward, allowing the housing to seat firmly behind the housing stop.*
7. Position upper die on upper mounting block and secure it loosely with the holding screws.
8. Carefully lower upper die by pulling handle forward and guiding staker serrations between ribs of receptacle housing.
9. Tighten the holding screws while upper die is bottomed.

4. CABLE TERMINATION

Cable termination is a *two-step* process. First, the ground conductors are terminated on the ground side of the receptacle (identified by the letter "G" on one

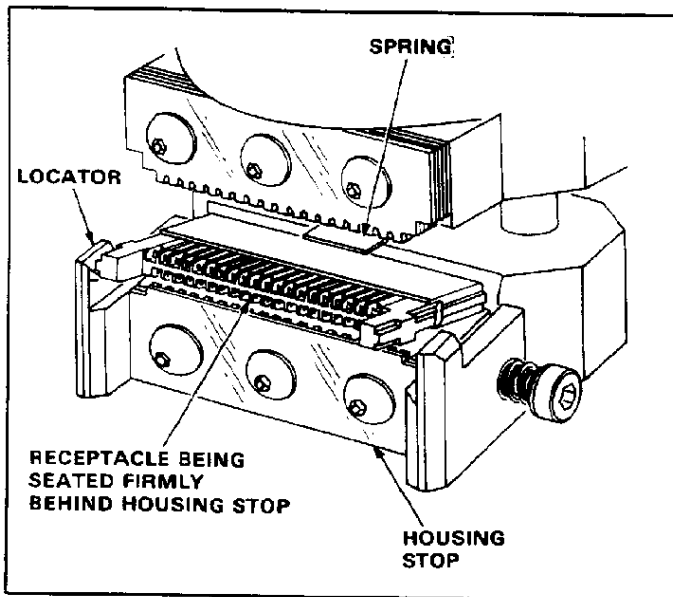

Fig. 4

end of the mating face of the housing), followed by termination of the center conductors on the signal side (identified by the letter "S" in the same location on the housing). (Although the cable wires can be terminated to either the signal or the ground side of

the receptacle first, this procedure suggests terminating the ground wires first.)

A. Ground Wire Termination

Refer to IS 2577 for selection of the appropriate cable and receptacle kit and for proper cable preparation, then proceed as follows:

1. Refer to Figure 4, and *locate* housing on lower die as described in Paragraph 3, APPLICATOR SETUP, Step 6.
2. Lay ground wires on contacts as shown in Figure 5. If necessary, use comb to align wires with "V" notches of contacts.

NOTE Center conductors are down, as shown in breakaway view of Figure 5.

3. Ensure that wires extend through at least *half the distance* between contacts and housing. See Figure 5.
4. Pull applicator handle forward to bottom upper dies on ground wires and contacts, terminating the wires.
5. Raise handle and remove receptacle housing.

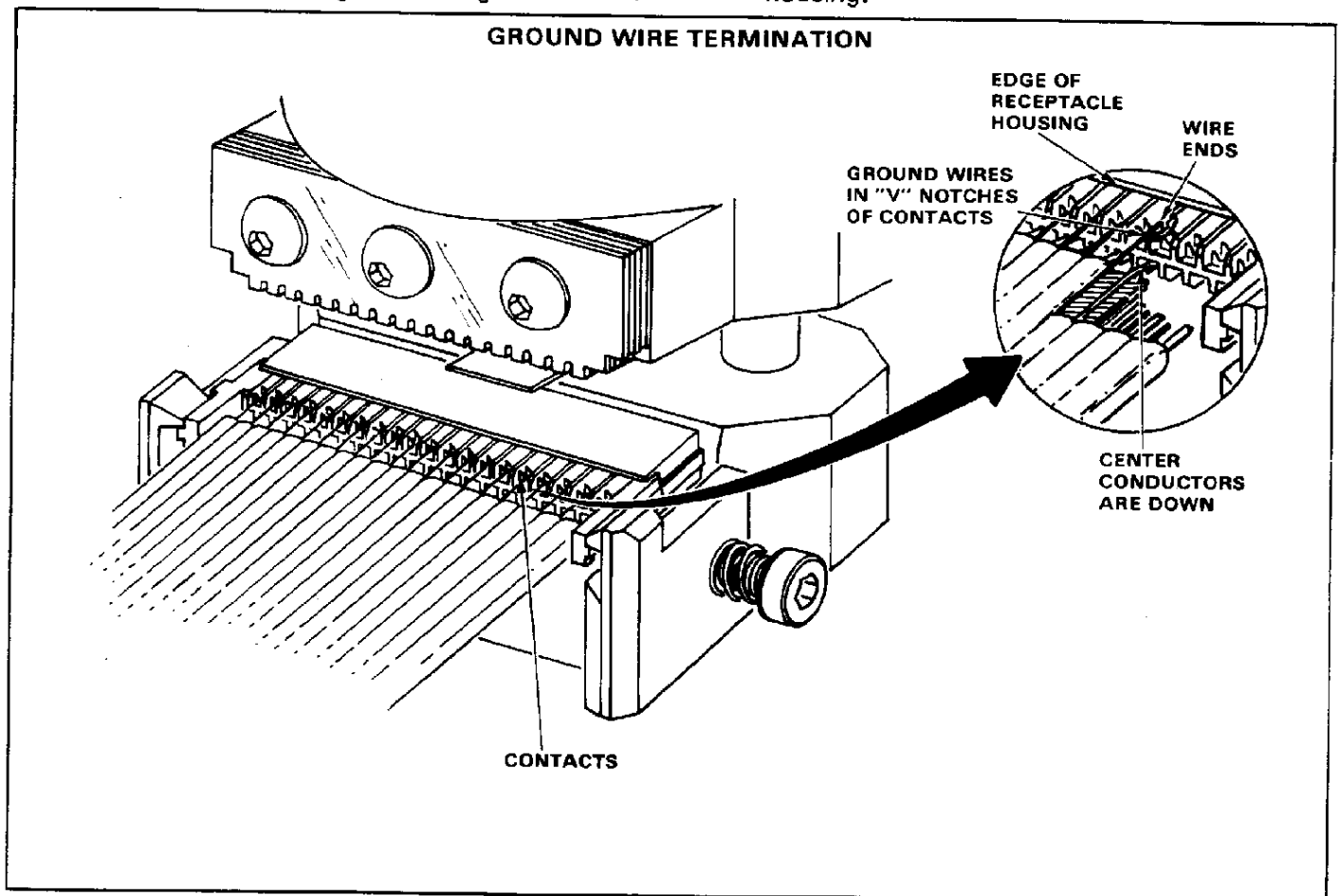

Fig. 5

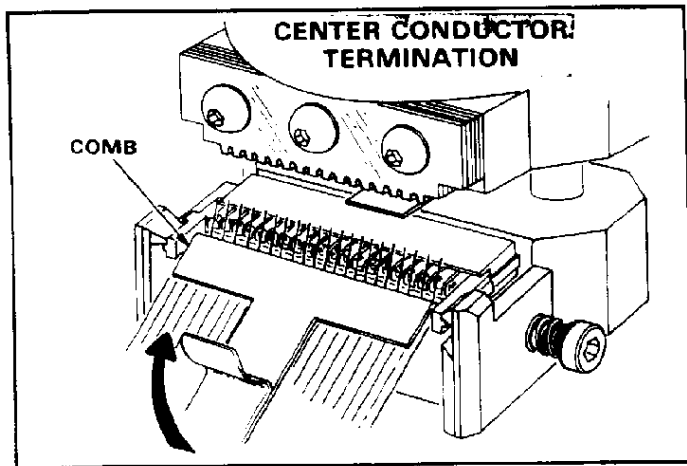

Fig. 6

B. Center Conductor Termination

1. Turn receptacle housing on its opposite side, "S" side UP, and reposition housing on lower die.
2. Refer to Figure 6, and, holding cable, position comb against conductors.
3. Lift cable to horizontal position, using comb to push conductors forward and down into crimping position.
4. Ensure that all wires are positioned in the "V" notches of contacts.
5. Pull handle of applicator forward to bottom upper die on wires (center conductors) and contacts, terminating the wires.
6. Rotate applicator handle back to starting position, and remove terminated receptacle from lower die.

7. Inspect terminated receptacle. See Paragraph 5, INSPECTION.

8. Refer to IS 2577, and assemble strain relief components over terminated receptacle.

5. INSPECTION

Refer to Figure 7, and inspect the wire insertion depth of the terminated receptacle.

6. CERTIFICATION

The ribbon cable applicator and dies should be certified with the information provided in Figures 8 and 9.

AMP recommends that the applicator, dies, and combs be thoroughly inspected *immediately* upon their arrival at your facility and at regularly scheduled intervals to ensure that no damage has occurred during handling.

A. Daily Maintenance

It is recommended that each operator of the applicator and dies be made aware of — and responsible for — the following four steps of daily maintenance:

1. Remove dust, moisture, and other contaminants with a clean brush, or a soft, lint-free cloth. Do NOT use objects that could damage the applicator and dies.
2. Make sure the proper die *stakers and spacers* are in place and secured with the proper retaining rings.
3. Make certain all pins, pivot points, and bearing surfaces are protected with a THIN coat of any good SAE No. 20 motor oil. Do NOT oil excessively.

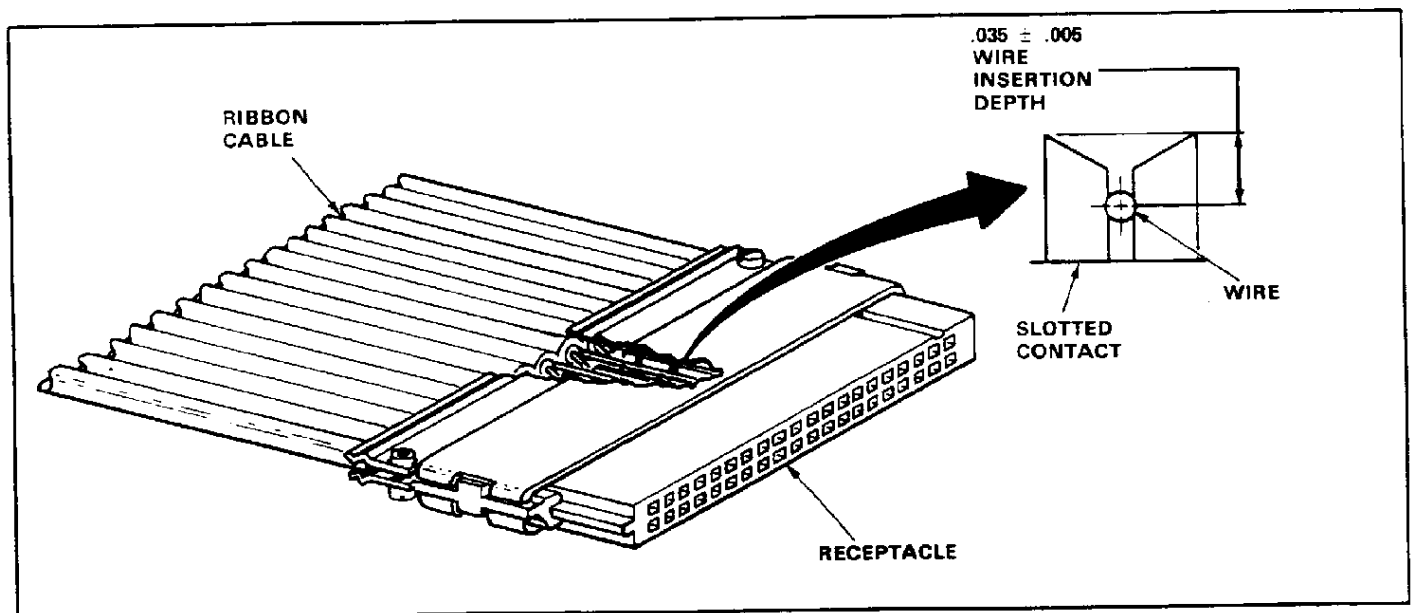
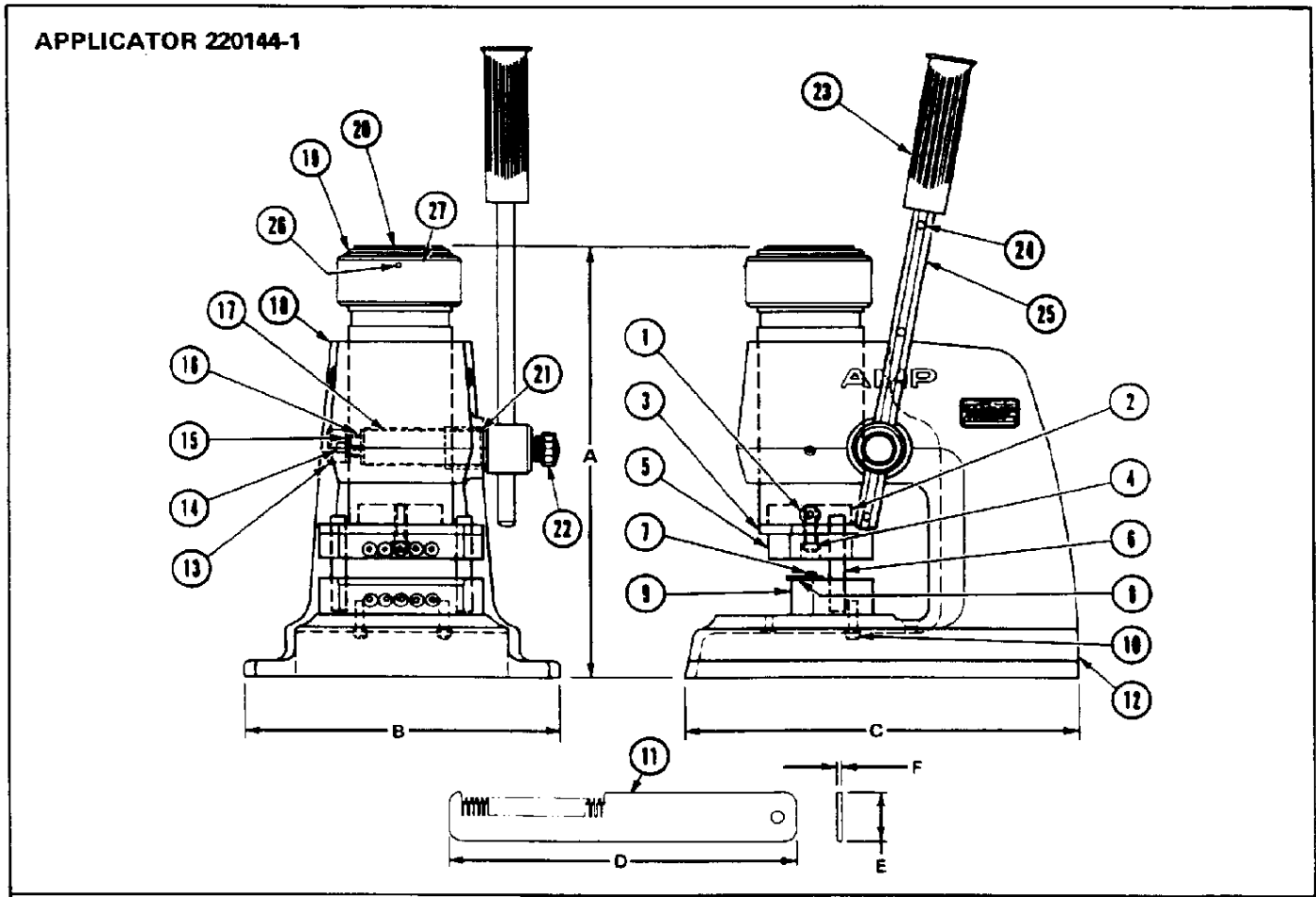

Fig. 7



APPLICATOR SPECIFICATIONS
DIMENSIONS

APPLICATOR	DIMENSIONS						WEIGHT
	A	B	C	D	E	F	
220144-1	9.00	7.95	9.50	7.00	1.00	.375	22 lb, 4 oz

APPLICATOR REPLACEMENT PARTS

ITEM	PART NUMBER	DESCRIPTION	QTY
1	2- 21003-0	SCREW, Fl Hd, Skt Hd, 6-32 x .500 L	2
2	308468-1	ADAPTER	1
3	308469-1	SPACER	1
4	3- 21000-9	SCREW, Skt Hd, 10-32 x 1.00 L	1
5	308470-1	MOUNTING BLOCK, Upper	1
6	5- 21030-1	DOWEL, Pin, 2.00 L	2
7	2- 21002-5	SCREW, Btn Hd, 10-32 x .250 L	1
8	308471-1	SPRING	1
9	308472-1	MOUNTING BLOCK, Lower	1
10	2- 21000-9	SCREW, Skt Hd, 8-32 x .75 L	2
11	310573-1	WIRE SEPARATOR	1
12	58024-1	ARBOR FRAME ASSY	1
13	2- 22484-1	PLUG, Btn	1
14	3- 21000-4	SCREW, Skt Hd, 10-32 x .375 L	1
15	6- 59591-6	WASHER	1
16	8- 22025-2	BUSHING	1
17	311480-1	PINION	1
18	311478-1	FRAME, Machined	1
19	311479-1	RAM	1
20	2- 22484-0	PLUG, Btn	1
21	1- 22027-6	BUSHING	1
22	27898-1	KNOB, Adj	1
23	19120-1	HANDLE, Grip	1
24	28053-2	PLUNGER, Spring	1
25	311481-1	SHAFT, Handle	1
26	22736-6	SETSCREW, Skt, 10-32 x .234 L	1
27	311534-1	RING, Adj	1

Fig. 8

4. When the applicator and dies are not in use, keep the upper and lower applicator mounts and dies closed to prevent objects from becoming lodged in the dies; store the applicator and dies in a clean, dry area.

When returning the applicator and/or dies to AMP Incorporated for repair, carefully package either one or both items along with a written description of the problem and send to:

B. Parts Replacement

The parts listed in Figures 8 and 9 can be replaced by qualified personnel at your facility or at our tool repair facility. All parts that are *not* listed must be replaced or repaired by AMP personnel.

AMP Incorporated
Customer Repair
1523 North Fourth Street
Harrisburg, PA 17102

or a wholly owned subsidiary of AMP Incorporated.

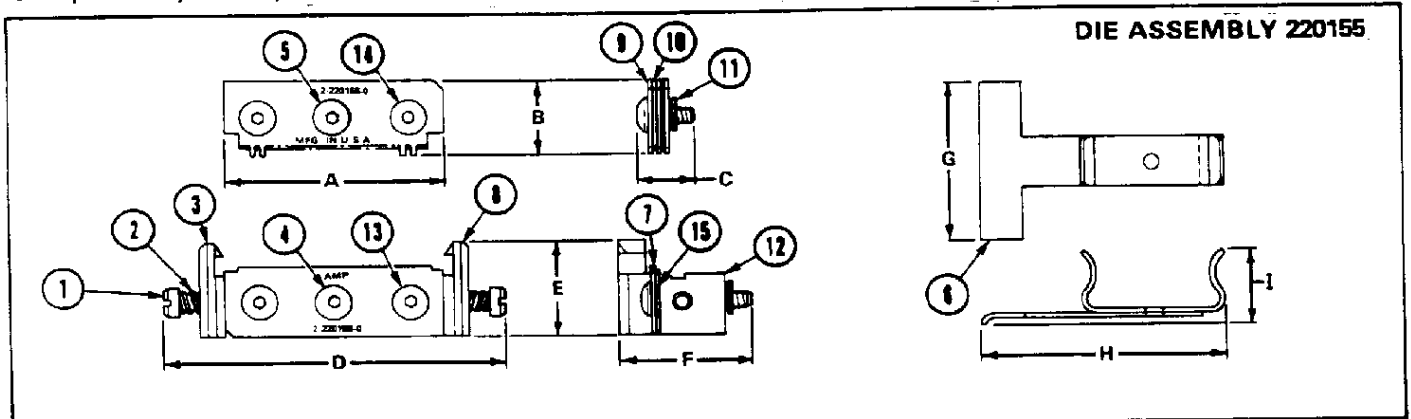

DIE SPECIFICATIONS DIMENSIONS

DIE ASSY	A	B	C	D	E	F	G	H	I	WEIGHT
220155-4	1.480	.775	.775	1.82	1.02	1.09	.440	2.00	.562	8 oz ⁴
-5				1.92			.540			10 oz ⁵
-6				2.02			.640			
-7				2.12			.740			
-8				2.22			.840			
-9				2.32			.940			
1-0				2.42			1.040			12 oz
1-3				2.72			1.340			
1-4	1.580			2.82			1.440			
1-5	1.680			2.92			1.540			
1-6	1.780			3.02			1.640			
1-7	1.880			3.12			1.740			14 oz
2-0	2.180			3.42			2.040			
2-5	2.680			3.92			2.540			

DIE REPLACEMENT PARTS

ITEM	PART NUMBER ¹	DESCRIPTION	QTY
1	1- 22353-1	SCREW, Shld Slit Hd, .187 Dia x .688 L	2
2	22280-1	SPRING, Comp, .240 OD x .375 L	2
3	308464-1	LOCATOR, Left	1
4	6- 59575-2	SCREW, Btn Hd Special	1
5	6- 59575-1	SCREW, Btn Hd Special	1
6	308467-()	COMB ASSY ²	1
7	308466-()	STOP, Housing ²	1
8	308465-1	LOCATOR, Right	1
9	312866-()	STAKER, Upper ²	3
10	312866-()	SPACER ²	2
11	1- 21046-3	RING, Retaining	2
12	308461-()	HOUSING BLOCK, Lower ²	1
13	3- 21002-1	SCREW ³ , Btn Hd, 10-32 x 1.00 L	1
14	2- 21002-1	SCREW ³ , Btn Hd, 8-32 x .375 L	1
15	308462-()	STAKER, Lower ²	1

ENGINEERING APPROVAL

DATE

[Signature]

12-10-84

- NOTE 1: WHERE NO FOOTNOTE IS INDICATED, THE PART NUMBER IS SAME FOR ALL DIE ASSEMBLIES.
- NOTE 2: DASH NUMBER IS SAME AS POSITION NUMBER: EG. 308466-4 IS A HOUSING STOP FOR A 4-POSITION DIE ASSEMBLY.
- NOTE 3: PRESENT ON 13-POSITION AND LARGER DIE ASSEMBLIES.
- NOTE 4: THE WEIGHT FOR 220155-4 DIE ASSEMBLY. WEIGHTS INCREASE SLIGHTLY AS RESPECTIVE DASH NUMBERS INCREASE.
- NOTE 5: THE WEIGHT FOR 1-220155-4 DIE ASSEMBLY. WEIGHTS INCREASE SLIGHTLY AS RESPECTIVE DASH NUMBERS INCREASE.

Fig. 9