

Figure 1

1. INTRODUCTION

AMP* Mass Insertion Terminating Head 58646-2, shown in Figure 1, is designed to terminate AMP MTA 156 feed-through receptacle connectors (positions 2 through 8) onto notched ribbon cable sizes 26 through 18 AWG with a maximum insulation diameter of 1.78 mm [.070 in.]. Refer to Figure 2 for reference connector part numbers.

NOTE This head is designed to terminate one connector at a time.

NOTE A complete list of current connector part numbers cannot be maintained on this document. For all part numbers and their description, refer to AMP Catalog 82056 or contact Product Information at the number at the bottom of this page.

The head is used with AMP Pistol Grip Manual Handle Assembly 58074-1. For terminating head installation procedures, and setup and operation of the handle assembly, refer to Instruction Sheet 408-6790. Read this and the referenced material before terminating any connectors.

NOTE Dimensions on this sheet are in metric units [with U.S. customary units in brackets]. Figures are not drawn to scale.

2. DESCRIPTION (Figure 1)

The terminating head, when properly installed onto the handle assembly, serves as a guide for the connector during termination.

Features of the head and their functions are as follows:

Wire Inserter—supports each wire so that, during the insertion cycle, it is forced into the two-slotted beam of the contact.

Wire Guide—positions the ribbon cable over the wire inserter.

Ram—locates and holds the connector while pushing it down onto the wires.

Locating Pawl—holds connector in proper alignment to the wire inserter.

Push Rod—used to push the terminated connector past the locating pawl for removal.

Insertion Rod Adjuster—is a piston for the ram and regulates the travel of the inserted wires.

Each wire is terminated in a connector contact using the insulation displacement technique (a terminating technique which inserts unstripped wire into a slotted contact beam to form a reliable electrical connection between the wire and the contact). Contact termination is complete when the handle assembly is actuated.

3. SETUP

3.1. Installing Head

The head can be installed onto the handle assembly and used as a hand-held tool, or several tools can be mounted onto a board to be used as a low-level harness board fixture.

The board must have two 6.36-mm [.250-in.] holes spaced 44.45 mm [1.75 in.] apart for each head. Secure each head with screws. See Figure 3.

WIRE SIZE (AWG)	MTA 156 FEED-THROUGH RECEPTACLE CONNECTORS*				
	COLOR CODE	WITH LOCKING RAMP		WITHOUT LOCKING RAMP	
		WITH POLARIZING TABS	WITHOUT POLARIZING TABS	WITH POLARIZING TABS	WITHOUT POLARIZING TABS
26	Blue	—	640595	—	641236
24	White	644468	640602	644472	640607
22	Red	644467	640601	644471	640606
20	Yellow	644466	640600	644470	640605
18	Orange	644465	640599	644469	640604

* Dash numbers indicate number of contact positions (-2 through -8 are applicable for this terminating head).

Figure 2

NOTE The handle assembly is not quick to install onto the head; therefore, each head should have its own handle assembly.

NOTE Wire retainers must be removed from test connectors to provide a clear view for inspection—do NOT use test connectors for production applications.

3.2. Test Termination

At least one test termination should be performed and inspected before starting production. Determine the wire size and select the appropriate color-coded connector.

2. Terminate the test connector according to Section 4 and inspect the connector following the requirements in Step 6. Make any insertion depth adjustments to the terminating head according to Section 5 before starting production.

Installing Head As Harness Board Fixture

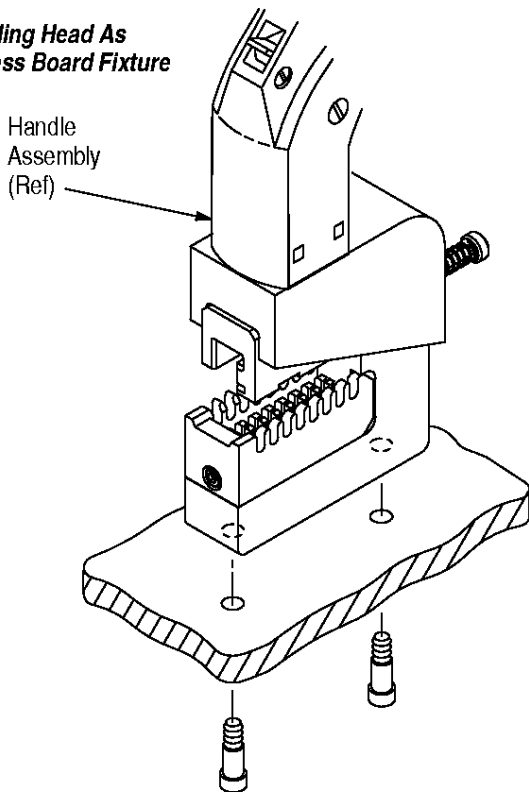

Figure 3

1. Using a small knife, cut off the wire retainers (strain relief) from both sides of the test connector. See Figure 5.

4. TERMINATING PROCEDURE

1. Position the pre-notched ribbon cable so that the first conductor goes into the wire guide slot closest to the head frame. See Figure 6. (See Figure 4 for ribbon cable limits and minimum notch length.)

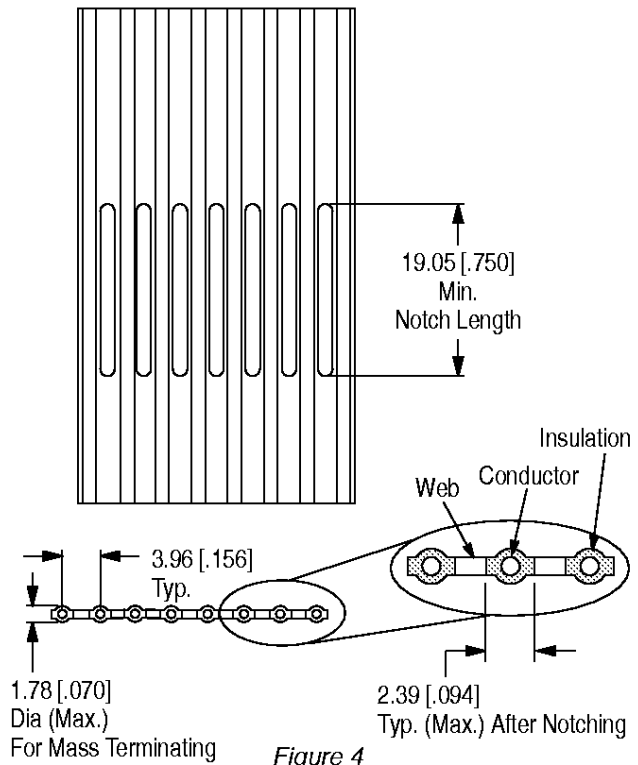

Figure 4

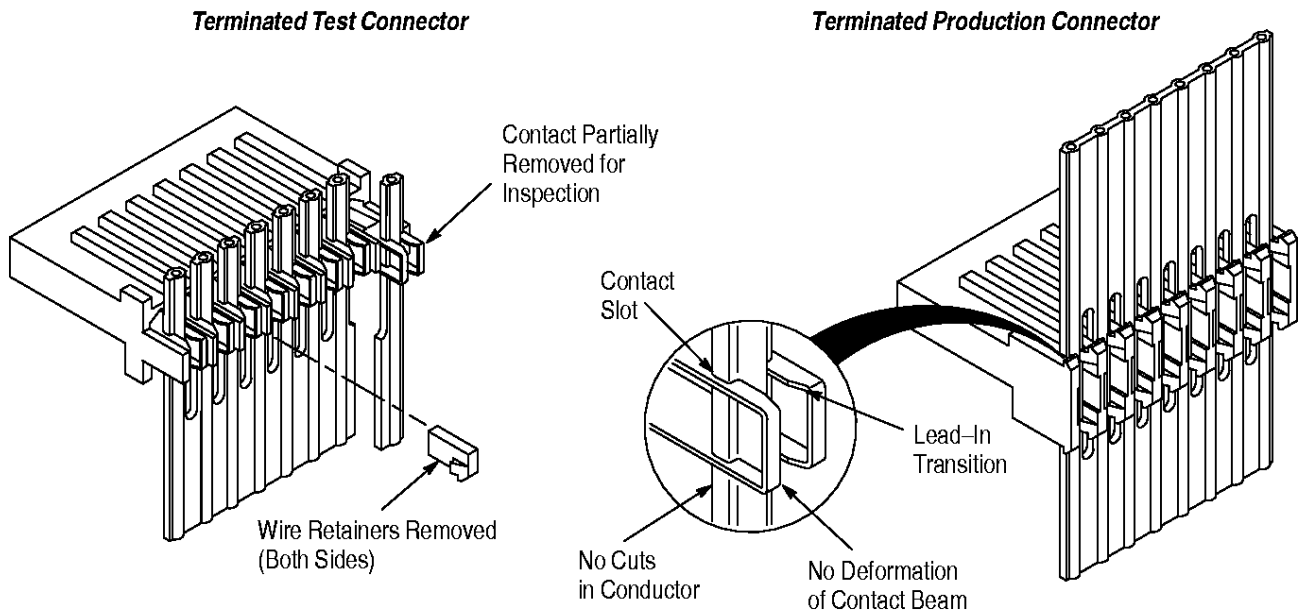

Figure 5

2. Insert the connector into the ram with the contact insulation barrels facing the wire slots.
3. Using a screwdriver (or equivalent), push the connector into the ram until the connector touches the surface of the frame. Refer to Figure 6.

NOTE To ensure proper alignment in the head, all connector positions must touch the surface of the head frame.

4. Actuate the handle assembly according to the instructions packaged with the handle assembly.

CAUTION After the ram completes the stroke, no conductors should be left in the wire slots. If any conductors are still in the slots, pull them up and out of the slots before continuing.

5. Depress the push rod to move the terminated connector beyond the locating pawl in the ram. Then grip the ribbon cable on both sides of the connector and carefully guide the connector out of the ram.

6. Refer to Figure 5 and visually inspect the connector according to the following. If wire insertion depth is found to be improper, refer to Section 5 for head adjustments.

CAUTION Wire insulation tends to return to form after being compressed. It is important to inspect the connector within five minutes of termination; otherwise, an improper inspection may result.

- Conductors are terminated past the lead-in transition and halfway into the contact slot.
- Conductors are not bottomed in contact slots.

- Insulation is not nicked or cut in any areas except in the contact slots.
- Contact beams are not deformed. If damage is evident, replace the damaged contact according to the instructions packaged with the connector.
- Conductor extends below the connector wire retainers.

NOTE For detailed inspection information, refer to AMP Application Specification 114-1020.

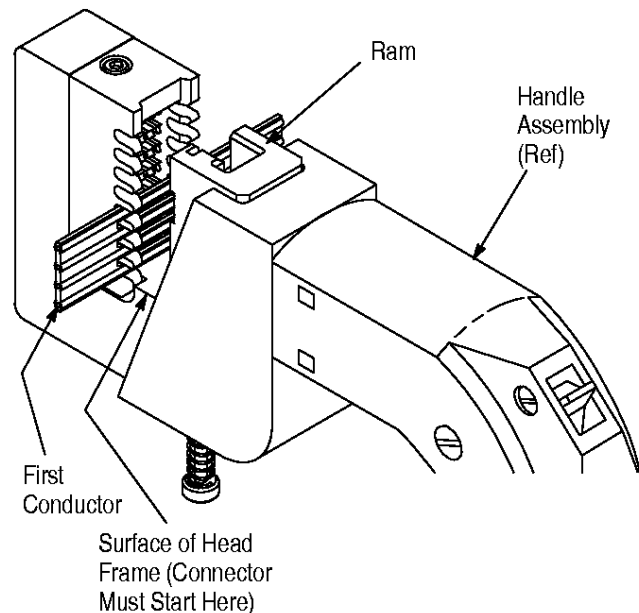

Figure 6

5. INSERTION DEPTH ADJUSTMENT

The terminating head is preset for nominal wire insertion depth; however, it may be necessary to make adjustments to the head, due to the wide range of cable sizes used, as follows:

1. Remove the head from the handle assembly.
2. If the conductors are too deep in the contact slots, turn the insertion rod adjuster *clockwise*. A $\frac{1}{6}$ -revolution will decrease the wire insertion depth by approximately 0.20 mm [.008 in.]. If the conductors are not deep enough in the contact slots, turn the adjuster *counterclockwise*. A $\frac{1}{6}$ -revolution will increase the wire insertion depth by approximately 0.20 mm [.008 in.]. See Figure 7.
3. Install the head onto the handle assembly; then terminate and inspect a test connector.
4. Repeat the adjustment as necessary until proper wire insertion depth is obtained. **DO NOT** use a tighter setting than required.

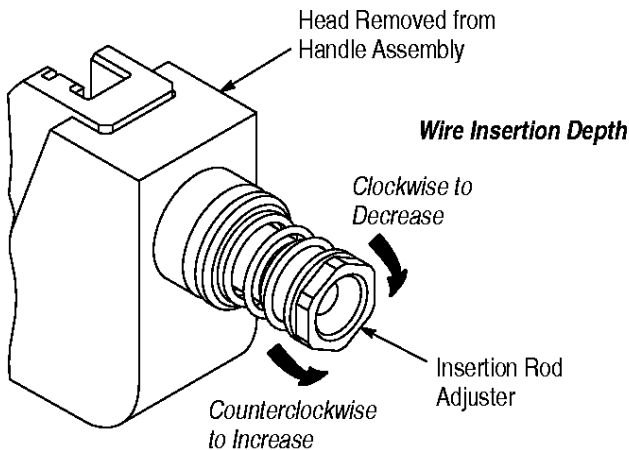

Figure 7

6. MAINTENANCE AND INSPECTION

AMP recommends that a maintenance and inspection program be performed periodically to ensure dependable and uniform terminations.

6.1. Daily Maintenance

1. Remove dust, moisture, and other contaminants with a clean, soft brush or a soft, lint-free cloth. Do **NOT** use objects that could damage the head.
2. Make sure that all pins, rings, and other components are in place and secure.
3. When head is not in use, store it in a clean, dry area.

6.2. Periodic Inspection

Regular inspections should be performed by quality control personnel. Though recommendations call for at least one inspection a month, the frequency should be based on amount of use, working conditions, operator training and skill, and your established company policies.

1. Remove all lubrication and accumulated film by immersing the head in a suitable commercial degreaser that will not affect paint or plastic.
2. Make certain all components are in place. If replacements are necessary, refer to Section 7.
3. Check all bearing surfaces for wear. Replace worn or damaged parts.
4. Inspect the head for flattened, chipped, or broken surfaces. Replace worn or damaged parts.

7. REPLACEMENT AND REPAIR

Replacement parts are listed in Figure 8. A complete inventory can be stocked and controlled to prevent lost time when replacement of parts is necessary. Order replacement parts through your AMP representative, or call 1-800-526-5142, or send a facsimile of your purchase order to 1-717-986-7605, or write to:

CUSTOMER SERVICE (38-35)
AMP INCORPORATED
PO BOX 3608
HARRISBURG PA 17105-3608

When repair is necessary, return terminating head (along with a written description of the problem) to:

CUSTOMER REPAIR (01-12)
AMP INCORPORATED
1523 NORTH 4TH STREET
HARRISBURG PA 17102-1604

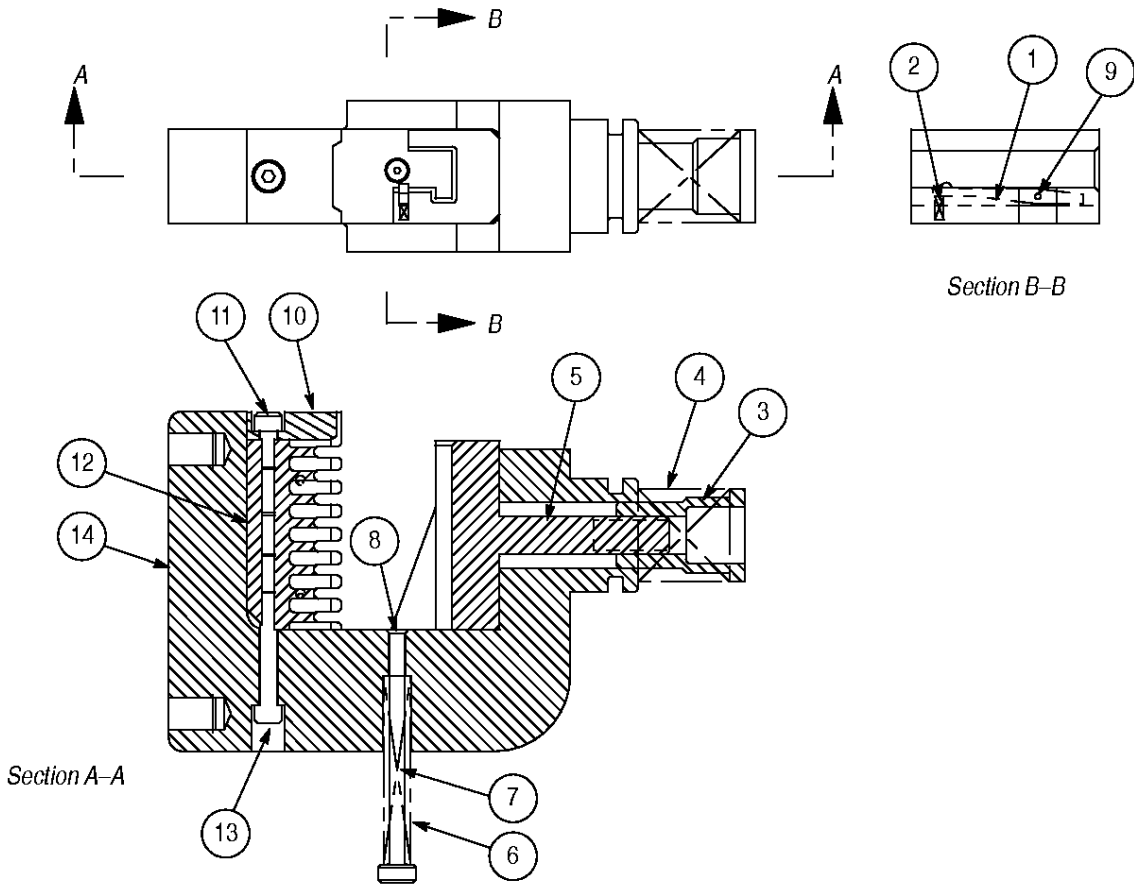

ITEM	PART NUMBER	DESCRIPTION	QTY PER HEAD
1	904092-1	PAWL, Locating	1
2	22279-1	SPRING, Compression	1
3	312149-1	ADJUSTER, Rod Insertion	1
4	22488-5	SPRING, Compression	1
5	904091-1	RAM	1
6	2-22279-5	SPRING, Compression	1
7	904093-1	ROD, Push	1
8	21003-1	SCREW, Flat Head Cap, 0-80 x .12	1
9	21949-1	PIN, Spiral Wrapped	1
10	904936-1	GUIDE, Wire	1
11	1-21000-4	SCREW, Socket Head Cap, 4-40 x .38	1
12	904088-1	BLOCK, Inserter	1
13	1-21000-7	SCREW, Socket Head Cap, 4-40 x .75	1
14	904083-1	HEAD	1

Figure 8