

AMP 1253 REV 7/68 8 7 6 5 4 3 2 1

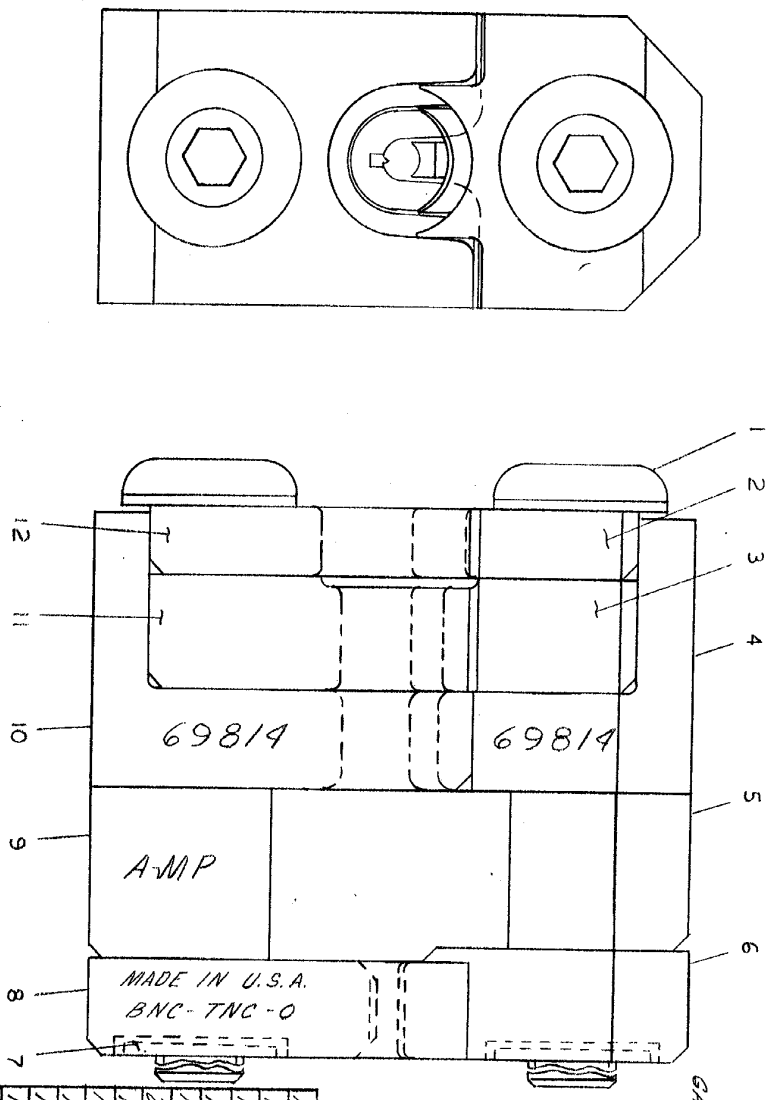

"O" CRIMP	NO GO
GO	.075
	.079

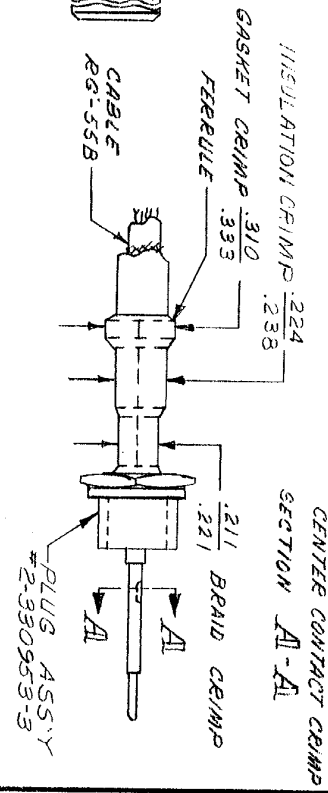

METHOD OF GAGING CRIMP DIMS.
 THE CRIMP DIMS. APPLY ONLY TO THE ABOVE
 COMBINATIONS ON A CRIMPED PRODUCT.
 SUPERSEDED BY LS 2610.

REVISION RECORD	DR	CHK	DATE	NUMBER	DESCRIPTION
B	306328	5-26-67			
A	REVIS	6-18-67			
				69814	

QTY	NUMBER	NAME	REMARKS	ITEM NO
1	306328	INDENTER - GASKET		12
1	306332-1	INDENTER - INSULATION		11
1	306330-1	INDENTER - BRAID		10
1	6-305832-7	SPACER		9
1	306949	INDENTER		8
2	1-21046-3	RING-RETAINING		7
1	45969-3	ANVIL - BARREL		6
1	1-59672-4	SPACER - UPPER		5
1	306331-1	ANVIL - BRAID		4
1	306333-1	ANVIL - INSULATION		3
1	306329	ANVIL - GASKET		2
2	7-306131-1	SCREW		1

DR: *Robert Lipe* 5-26-67
 CHK: *Robert Lipe* 6-18-67
 MATERIAL AND FINISH: *H*
 CLASS: *H*
 WIRE RANGE - INSULATION: *7*
 TOLERANCE EXCEPT SCALE: *4-1*
 LOC: *M* NO: *B* REV: *B*
 NAME: *DIE ASSEMBLY*
 PART NO: *69814*

REQUIRED PER ASSEMBLY
 61869
 CUSTOMER COPY
 AMP INCORPORATED
 HARRISBURG, PENNA.