

DIE ASSEMBLY NUMBER	TERMINAL				WIRE	
	PART NUMBER (TAPE MOUNTED)	SERIES	INSULATION COLOR	RANGE (AWG)	STRIP LENGTH ±0.41 [.016]	INSULATION DIA (Max)
90248-2	60894-2 61048-2 61060-2	.110	Clear	22 - 18	5.56 [.219]	2.54 [.100]
90240-2	42844-3	.250	Green	14 - 12	8.74 [.344]	6.35 [.250]
90280-1	61198-4		Yellow	12 - 10	7.14 [.281]	

Figure 1

**1. INTRODUCTION**

This instruction sheet covers die assemblies that are used to crimp AMP\* PIDG FASTON Terminals. Refer to Figure 1 for appropriate die assembly and terminal combinations. The dies and terminals are color coded to indicate accepted wire range. The dies fit into the AMP-TAPETRONIC Machine 69875. Refer to AMP customer manual 409-1993.

**NOTE** All dimensions on this sheet are in millimeters [with inch equivalents provided in brackets]. Figures and illustrations are for identification only and are not drawn to scale.

Read these instructions carefully and completely before crimping any terminals.

Reasons for reissue of this instruction sheet are provided in Section 7, REVISION SUMMARY.

**2. DESCRIPTION** (Figure 1)

Each die assembly consists of a stationary die and a moving die. The stationary die has a die holding

screw. The moving die has a die holding screw and a saddle with an assembly screw, and it is marked to indicate the wire range crimped.

**3. DIE INSTALLATION**

Prepare the machine to receive dies according to the instructions in 409-1993 under "Die Replacement", and proceed as follows:

1. Position the moving die into the upper crimping area of the machine and finger tighten the holding screw.
2. Position the stationary die into the lower crimping area of the machine and start the holding screw, but do not tighten it.
3. Hand cycle the machine until the dies bottom against each other. Tighten both holding screws.

Re-assemble and adjust the machine, again following the instructions provided in 409-1993.

## 4. PREPARATION AND CRIMPING

Install a reel of terminals on the machine and align a terminal with the dies. Refer to customer manual 409-1993.

**CAUTION** *Crimp only terminals specified for the dies you are using.*

Refer to Figure 1 to verify the correct wire size and insulation diameter for the product you intend to crimp.

### 4.1. Insulation Crimp Adjustment

1. With the machine power supply disconnected and the front guard removed, raise the tape release lever and turn the insulation crimp adjustment knob to position No. 4 (loose). Then lower the tape release lever.
2. Insert an *unstripped* wire into the terminal, and hand cycle the machine one full crimp cycle.
3. Remove the crimped terminal from the machine. Bend the wire 90° to both sides. If the wire pulls out of the terminal, raise the release lever, turn the adjustment to next lower number, and lower the release lever. Then repeat steps 2 and 3 until the crimp is properly adjusted.

**NOTE** *The insulation crimp should hold the wire insulation firmly without cutting into it.*

### 4.2. Crimping Procedures

Strip the wires to the dimension shown in Figure 1, being careful not to cut or nick the conductor strands. Then, proceed as follows:

1. Insert the stripped end of a wire into the aligned terminal until the wire insulation begins to wedge against the terminal insulation barrel, or until it is against the end of the terminal wire barrel.
2. Hold the wire in place and actuate the machine through a complete cycle.

**NOTE** *Be sure to allow the crimping dies to open fully before removing the crimped terminal.*

### 4.3. Crimp Inspection (Figure 2)

Visually inspect completed crimps, noting the following:

- Ends of wire strands must be flush to, or extend beyond, the front of the wire barrel. However, ends may not extend far enough to interfere with insertion of the mating tab.
- Wire insulation must be inside the insulation barrel with no conductor showing.

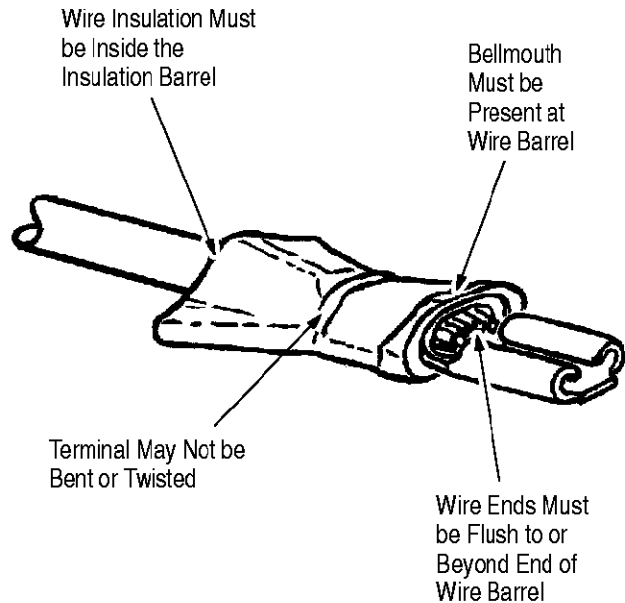

Figure 2

— A slight bellmouth must be present in the terminal plastic insulation at the front of the wire barrel.

— Terminal may not be bent or twisted in a way that damages the termination or makes mating difficult.

**NOTE** *For more information on product crimp specifications, refer to AMP application specification 114-1002.*

## 5. MAINTENANCE AND INSPECTION

### 5.1. Daily Maintenance

1. Remove dust, moisture, and other contaminants with a clean, soft brush, or a clean, soft, lint-free cloth. Do NOT use any objects that could damage the dies or tool.
2. Make sure all die hardware and parts are properly secured.
3. Coat all surfaces with a thin coat of any good SAE 20 motor oil. Do not oil excessively.
4. When the dies are not in use, store them in a clean, dry area.

### 5.2. Periodic Inspection

Regularly scheduled inspections should be conducted and recorded by quality control personnel. It is recommended that the inspection procedures that follow be performed once a month; more often if your work environment, company standards, or amount of tool use indicates the need.

**A. Visual Inspection**

Remove all lubrication and accumulated film by immersing the dies in a commercial degreaser. Then:

1. Remove all lubrication and accumulated film from the dies by immersing the dies in a suitable commercial degreaser.
2. Make sure all die hardware and parts are properly secured.
3. Carefully inspect die surfaces for wear, cracking, pitting, or other obvious damage. Replace parts as necessary before returning dies to service. See Figure 4.

**B. Gaging the Wire Barrel Crimping Chamber (Figure 3)**

Figure 3 shows dimensions for manufacture of plug gages needed to inspect the wire barrel crimping chamber of each die assembly. Tyco does not make or market these gages. However, gages may be purchased from:

Pennoyer-Dodge Company  
6643-T San Fernando Road  
Glendale, CA 91201

Gage crimping chamber using the following procedures:

1. Close dies until bottomed, and hold them in this position.
2. Align the plug gage GO element with the crimping chamber. Push the element straight into the chamber, but do not force it. The GO element must pass through the chamber.
3. Align the NO-GO element and try to insert it straight into the crimping chamber. The NO-GO element may begin entry as shown in Figure 3, but must not pass through the chamber.

If dies conform dimensionally, lubricate them with a thin coat of any good SAE 20 motor oil. If not, replace the dies.

For additional information on plug gages, refer to instruction sheet 408-7424.

**6. REPLACEMENT AND REPAIR**

Replacement parts are listed in Figure 4. Parts other than those listed in Figure 4 should be replaced by Tyco to ensure quality and reliability of the dies. Order replacement parts through your Tyco representative, or call 1-800-526-5142, or send a facsimile of your purchase order to 1-717-986-7605, or write to:

**Suggested Plug Gage Design**

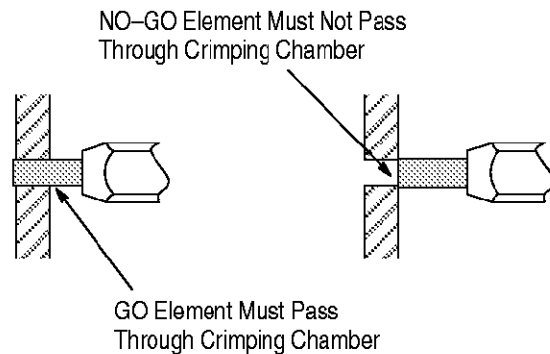
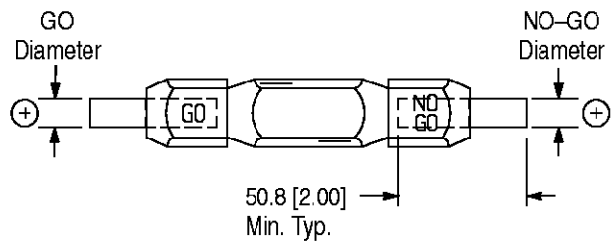

CRIMPING DIE NUMBER	GAGE ELEMENT DIAMETER	
	GO	NO-GO
90240-2	3.52 [.1385]	3.64 [.1435]
90248-2	1.59 [.0625]	1.71 [.0675]
90280-1	3.80 [.1495]	3.95 [.1555]

Figure 3

CUSTOMER SERVICE (38-35)  
TYCO ELECTRONICS CORPORATION  
P.O. BOX 3608  
HARRISBURG, PA 17105-3608

For repair service, please contact a representative at 1-800-526-5136.

**7. REVISION SUMMARY**

Since the previous release of this sheet, the following changes were made:

Per EC 0990-0714-00

- Updated document to corporate requirements
- Added metric dimensioning
- Changed strip length in Figure 1 for Die 90240-2 from .250 to .344
- Changed customer repair address in Section 6, REPLACEMENT AND REPAIR
- In Figure 4, changed Wire Anvil part number for Die 90280-1 from 2-307285-3 to 125968-1
- Changed document title

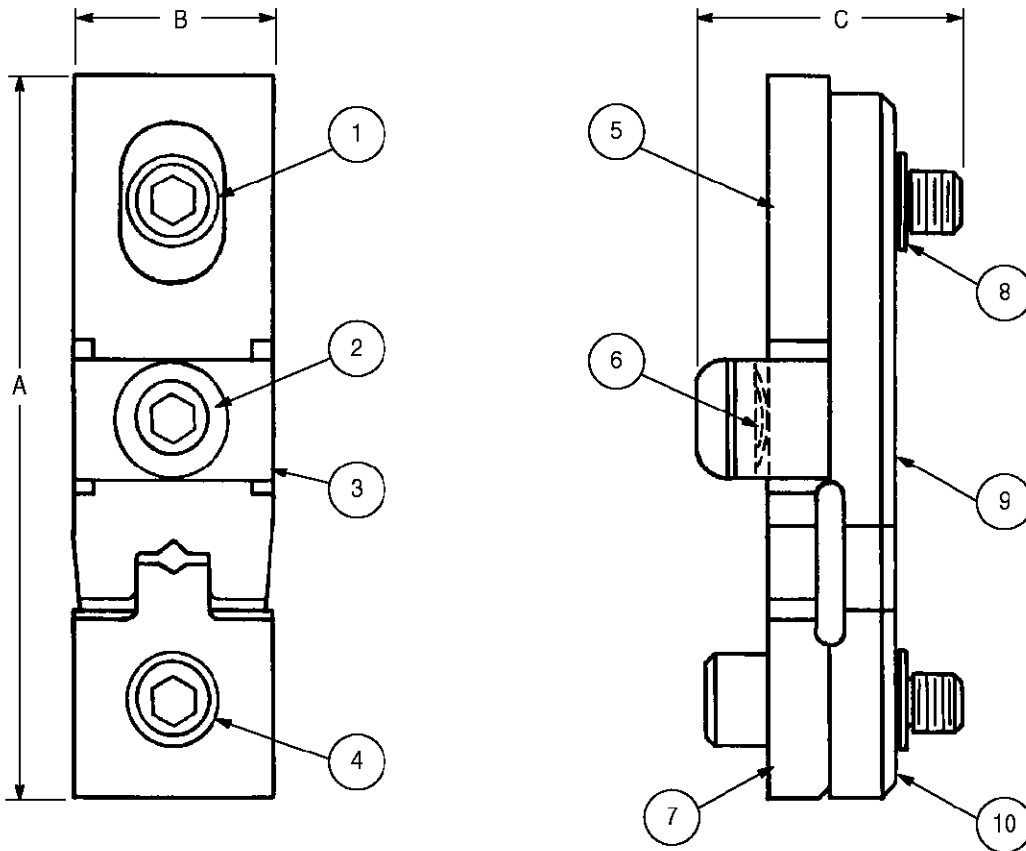

DIE SPECIFICATIONS				REPLACEMENT PARTS					
DIE NUMBER	DIMENSION (Ref)			ITEM	DIE 90240-2	DIE 90248-2	DIE 90280-1	DESCRIPTION	QTY PER ASSY
	A	B	C						
90240-2	56.64 [2.230]	15.85 [.624]	28.63 [1.127]	1	59781-1	2-59781-3	59781-1	Die Holding Screw	1
				2	2-59577-8	2-59577-9	2-59577-8	Saddle Screw	1
90248-2	56.64 [2.230]	15.85 [.624]	26.24 [1.033]	3	1-307275-0	1-307275-2	1-307275-0	Saddle	1
				4	1-59781-0	59781-6	59781-5	Die Holding Screw	1
90280-1	56.64 [2.230]	15.85 [.624]	28.63 [1.127]	5	307276-5	2-307285-3	307276-1	Insulation Crimper	1
				6	24088-8	24088-8	24088-8	Curved Washer	1
				7	3-59619-7	3-59619-9	1-59619-2	Insulation Anvil	1
				8	1-21046-3	1-21046-3	1-21046-3	Retaining Ring	2
<b>DIE WEIGHT (Ref)</b>				9	125719-1	125782-1	125969-1	Wire Crimper	1
142 g [5 oz.]				10	125721-1	125781-1	125968-1	Wire Anvil	1

Figure 4