

DIE ASSEMBLY		SPLICE	
PART NUMBER	MARKING	SIZE	MINIMUM OPENING DIAMETER
45218	18-16 ECV-ECN	22-14	—
45221	18-10 ECV-ECN	22-10	—
69303-2	18-16 EC	22-16	6.73 mm [.265 in.]
69820	18-16 ECVG	22-16	6.48 mm [.255 in.]

Figure 1

## 1. INTRODUCTION

AMP\* Die Assemblies 45218, 45221, 69303-2 (shown in Figure 1), and 69820 are used with Hand Crimping Tool 69710-1 or 626 Pneumatic Tooling Assembly 189721-1 or 189722-1 fitted with Straight Action Crimper 217200-1, or 189721-2 or 189722-2 fitted with C-Head Pneumatic Adapter 318161-1 to crimp vinyl and nylon closed end splices onto solid and stranded wire sizes 22 through 10 AWG.

For splice part numbers, refer to Catalog 65472, or call Product Information at the number listed at the bottom of this page. For specific information concerning the hand tool, refer to Instruction Sheet 408-2095; for the pneumatic tooling assembly, refer to Customer Manual 409-5862; for the crimper, refer to 408-4195; and for the adapter, refer to 408-4190. Read these instructions and referenced materials before crimping any splices.

### NOTE

Dimensions on this sheet are in millimeters [with inches in brackets]. Figures are not drawn to scale.

Reasons for reissue of this instruction sheet are provided in Section 8, REVISION SUMMARY.

## 2. DESCRIPTION

The die assembly consist of an insert indenter (moving die) and an insert anvil (stationary die). The stationary die is identified by the chamfered corners. The stationary die is marked with the die assembly part number, wire size (AWG), and splice type. When mated, the die assembly forms one crimping chamber. Each die is secured in the tool by a single screw.

## 3. DIE INSTALLATION

Install die assembly onto tool according to the specific instructions supplied with the tool. If using the pneumatic tooling assembly, follow the instructions supplied with the applicable crimper or adapter.

## 4. CRIMPING PROCEDURE

### NOTE

Die Assembly 69820 requires an insulation crimp adjustment. Before crimping any splices, refer to Section 5 for proper adjustment.

1. Select proper wire combinations as stated in the applicable wire combination chart specified in Figure 2. Strip wires to length indicated in Figure 2. Do not use wires with nicked or missing strands.

### NOTE

If conductors are twisted together to form a tight bundle before inserting them into the splice, the strip length must be maintained after twisting.

2. Insert splice, wire barrel first, into the ejector of the stationary die until splice bottoms. For nylon splices, the shoulder must rest against the ejector; for vinyl splices, the end of the wire barrel of must rest against the locator. Die Assembly 69820 does not have a locator; therefore, the wire barrel must rest against the wire barrel section of the die. See Figure 3. Close dies until splice is held in place.

3. Insert stripped wires into splice wire barrel until conductors bottom. See Figure 3.

### DANGER

Always keep fingers clear of dies during tool operation.

4. Hold wires in place, and actuate the tooling through a complete cycle.

**Typical Closed End Splice**

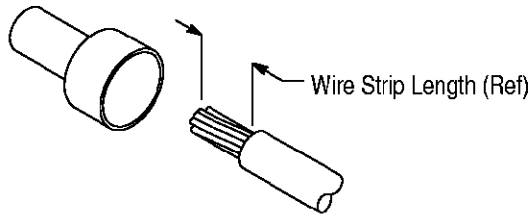

SPLICE		WIRE COMBINATION CHART	WIRE STRIP LENGTH
SIZE	TYPE		
22-16	ECV	408-1395 (6.73 [.265] Splice Min Opening Dia)	7.94-8.73 [.312-.344]
		408-2228 (6.48 [.255] Splice Min Opening Dia)	10.32-11.90 [.406-.469]
22-14	VS	408-1394	8.33-9.13 [.328-.359]
	ECN	408-1271 (Transparent Splice)	
		408-8806 (Black Splice)	
22-10	ECV	408-1002	14.29-15.87 [.562-.625]
	ECN	408-1021	10.72-11.51 [.422-.453]

Figure 2

5. Allow the dies to open FULLY, then remove the crimped splice (if splice is difficult to remove, twist splice one-quarter turn). Inspect the crimped splice according to Figure 4.

**NOTE** For detailed information on inspection requirements, refer to Application Specification 114-2147 for nylon and 114-2149 for vinyl splices.

**5. INSULATION CRIMP ADJUSTMENT**

(For Die Assembly 69820 Only)

The moving die has three insulation adjustment settings to adjust the wire insulation grip: 1—Tight, 2—Medium, and 3—Loose. To determine the proper insulation crimp setting, proceed as follows (refer to Figure 5):

1. Remove moving die from tool.
2. Loosen, but do not remove, the die screw. Set the insulation crimp adjustment to Setting 1 (as described in Figure 5).

**Nylon Splices**

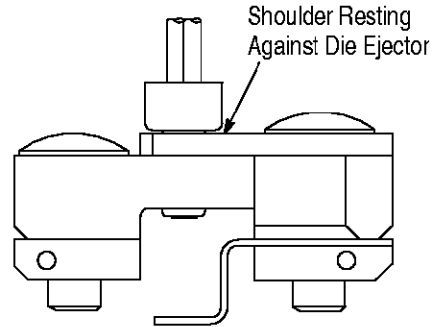

**Vinyl Splice**

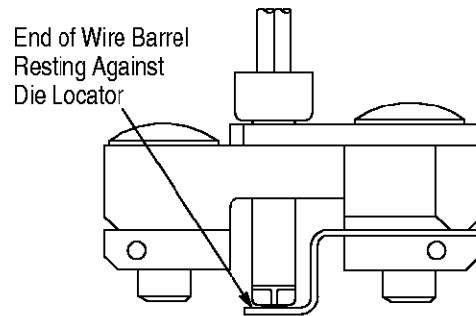

**Nylon or Vinyl Splice in Die Assembly 69820**

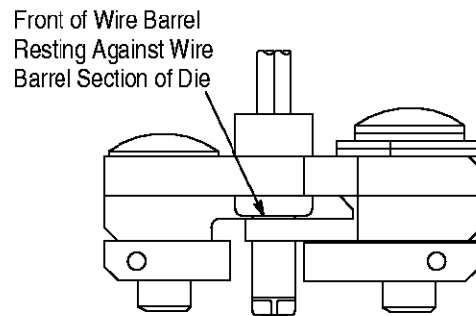

Figure 3

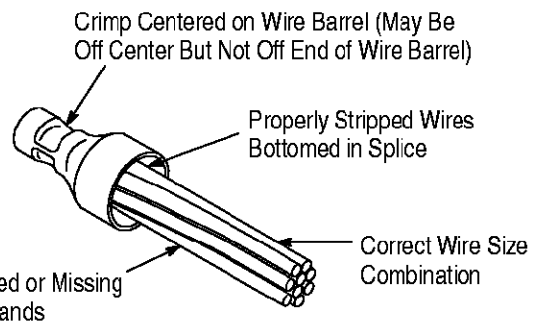

Figure 4

**Setting 1—Tight**

Turn both insulation adjustment spacers until the "1" (stamped on the die) is visible at the beveled corner of the spacers. When installed into the tool, the L-shaped edge of the spacers will fit between the die and the tool.

**Setting 2—Medium**

Turn the insulation adjustment spacer closest to the die until the "2" (stamped on the die) is visible at the beveled corner of the spacer. When installed into the tool, the L-shaped edge of the spacer will fit between the die and the tool.

**Setting 3—Loose**

Turn both insulation adjustment spacers until the "3" (stamped on the die) is visible at the beveled corner of the spacers. The L-shaped edge of the spacer will fit into the notch in the side of the die.

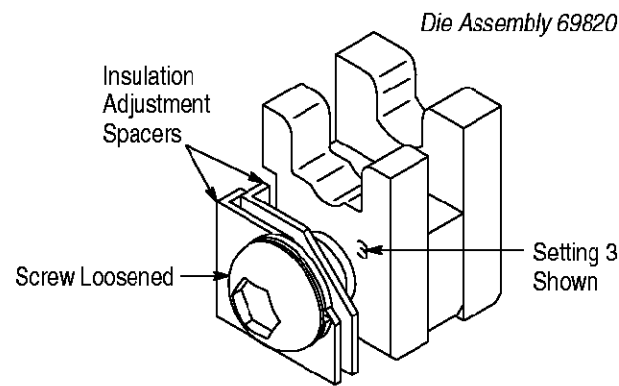

Figure 5

3. Tighten the die screw. Install die into tool.

4. Perform a test crimp following the steps in Section 4, and inspect the splice insulation. If the crimp cuts into, or otherwise damages, the insulation, start with Step 1 and set the insulation crimp adjustment to the next setting (Setting 2, as described in Figure 5). Perform another test crimp. If the crimp does not meet requirements, set the adjustment to Setting 3. If the crimp meets requirements, the adjustment is properly set.

## 6. MAINTENANCE AND INSPECTION

### 6.1. Daily Maintenance

It is recommended that each operator of the die assembly be made aware of, and responsible for, the following steps of daily maintenance:

1. Remove all foreign particles from the dies with a clean, soft brush, or a clean, soft, lint-free cloth. Do not use objects that could damage the dies.
2. Make sure that the proper screws and retaining rings are in place and are secured. Check die alignment and tighten screws (twice daily is recommended for production use).

3. Make certain that the dies are protected with a thin coat of any good SAE 20 motor oil. Do NOT oil excessively.

4. When dies are not in use, mate them and store them in a clean, dry area.

### 6.2. Periodic Inspection

Regular inspections should be performed by quality control personnel with a record of scheduled inspection remaining with the die assembly or supplied to personnel responsible for them. Though recommendations call for at least one inspection per month, inspection frequency should be based upon amount of use, working conditions, operator training and skill, and established company standards. The inspections should be performed in the following sequence.

1. Remove all lubrication and accumulated film by immersing the dies in a suitable commercial degreaser that will not affect paint or plastic material.
2. Make sure that screws, retaining rings, and die components are in place.
3. Check all bearing surfaces for wear. Replace worn components.
4. Inspect the crimping chamber for flattened, chipped, cracked, worn, or broken areas. If damage is evident, the dies must be repaired before returning them to service.

### 6.3. Gaging the Crimping Chamber

This inspection requires the use of plug gages conforming to the dimensions provided in Figure 6. Tyco does not manufacture or market these gages. To gage the crimping chamber, proceed as follows:

1. Remove traces of oil or dirt from the crimping chamber and plug gage.
2. For pneumatic tools, reduce air supply pressure on tool to between 103 and 138 kPa [15 and 20 psi]. Actuate tool until dies bottom. For manual tools, close handles until dies bottom. Do NOT force beyond initial contact.
3. Insert GO element into the crimping chamber; but do not force it. The GO element must pass completely through the crimping chamber. See Figure 7.
4. In the same manner, try to insert the NO-GO element into the crimping chamber. The NO-GO element may enter partially, but must not pass completely through the length of the crimping chamber. See Figure 7.

**Suggested Plug Gage Design for Wire Barrel Section**

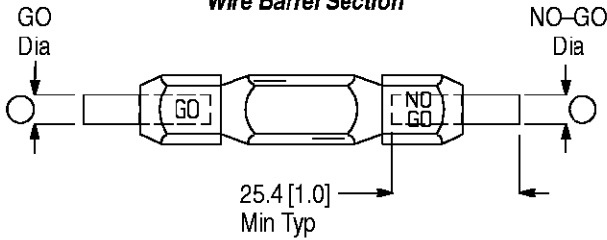

Die Closure Configuration

DIE ASSEMBLY	GAGE ELEMENT DIAMETER	
	GO	NO-GO
45218	2.3114-2.3190 [.0910-.0913]	2.4613-2.4638 [.0969-.0970]
45221	3.1242-3.1318 [.1230-.1233]	3.2741-3.2766 [.1289-.1290]
69303-2	2.6670-2.6746 [.1050-.1053]	2.8169-2.8194 [.1109-.1110]
69820	2.6670-2.6746 [.1050-.1053]	2.8169-2.8194 [.1109-.1110]

**Suggested Plug Gage Design for Insulation Barrel Section**

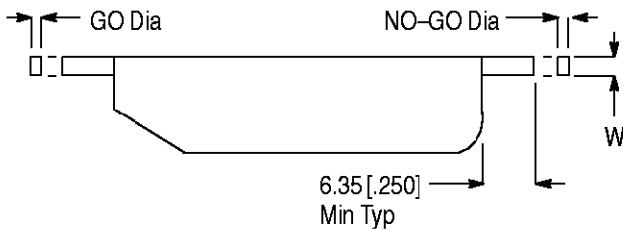

Die Closure Configuration

DIE ASSEMBLY	GAGE ELEMENT DIAMETER		DIMENSION "W" WIDTH (Max)
	GO	NO-GO	
69820	3.7846-3.7922 [.1490-.1493]	4.2901-4.2926 [.1689-.1690]	7.49 [.295]

Figure 6

**Inspection of Crimping Chamber**

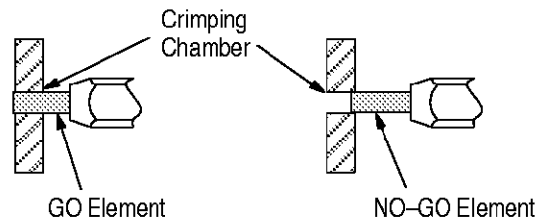

Wire barrel GO element must pass completely through the crimping chamber.

NO-GO element may enter partially, but must not pass completely through the crimping chamber.

Figure 7

If the crimping chamber conforms to the gage inspection, the dies may be considered dimensionally correct and should be lubricated with a THIN coat of any good SAE 20 motor oil. If the crimping chamber does NOT conform to the gage inspection, the die assembly must be returned to Tyco for further evaluation and repair.

For additional information regarding the use of a plug gage, refer to 408-7424.

**7. REPLACEMENT AND REPAIR**

Customer-replaceable parts are listed in Figure 8. A complete inventory should be stocked and controlled to prevent lost time when replacement of parts is necessary. Order replacement parts or additional dies through your representative, or call 1-800-526-5142, or send a facsimile of your purchase order to 717-986-7605 or write to:

CUSTOMER SERVICE (038-035)  
TYCO ELECTRONICS CORPORATION  
PO BOX 3608  
HARRISBURG PA 17105-3608

Dies may also be returned for evaluation and repair. For die repair service, please contact a representative at 1-800-526-5136.

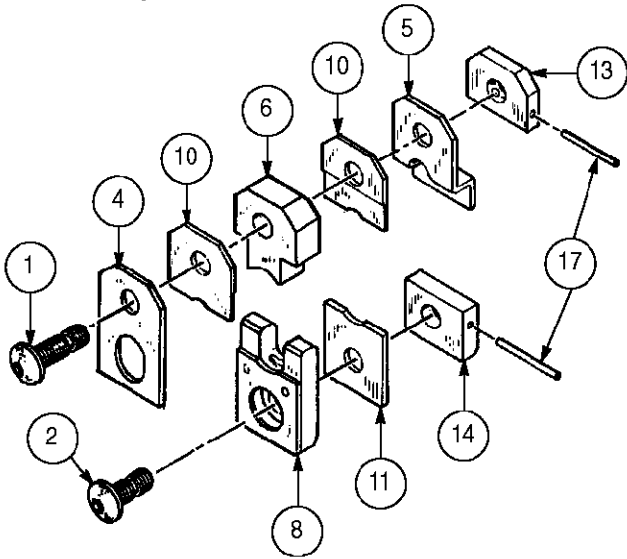
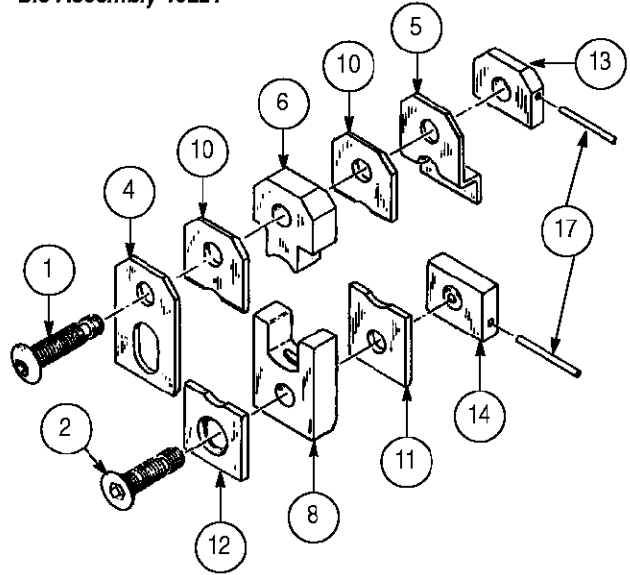
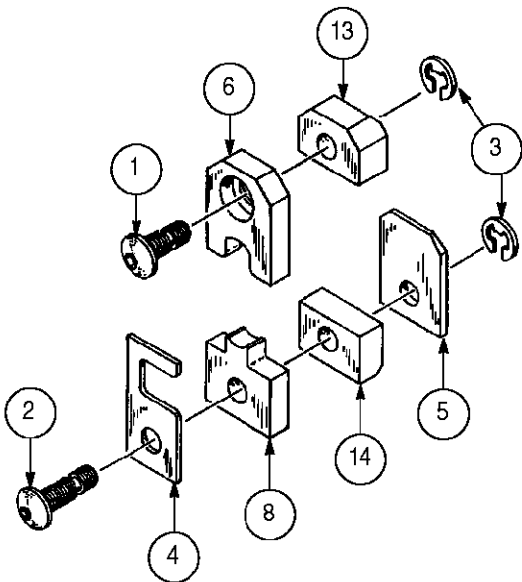
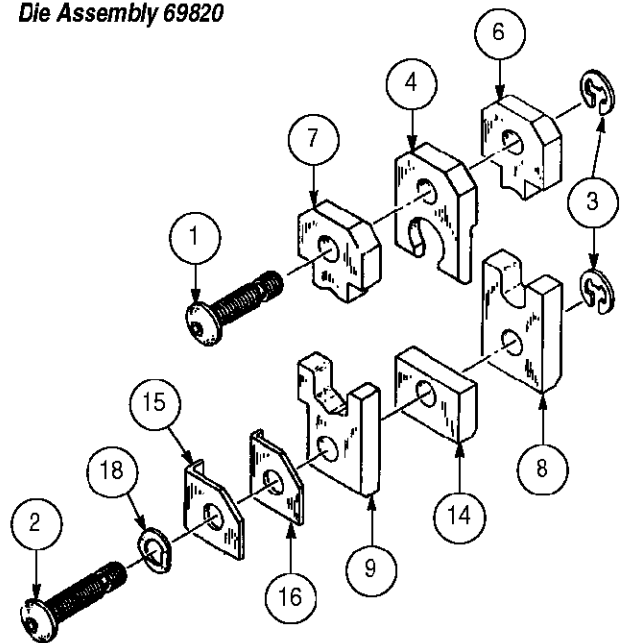
**Die Assembly 45218****Die Assembly 45221****Die Assembly 69303-2****Die Assembly 69820***Figure 8 (cont'd)*

ITEM	PART NUMBER FOR DIE ASSEMBLY				DESCRIPTION	QTY PER ASSEMBLY
	45218	45221	69303-2	69820		
1	304993	305037	1-305927-8	2-306131-1	SCREW	1
2	304991	305036	2-306131-4	3-306131-7	SCREW	1
3	—	—	1-21046-3	1-21046-3	RING, Retaining	2
4	304995	305042	306113-2	2-306113-9	EJECTOR	1
5	304992	305035	306024-8	—	LOCATOR	1
6	45296	45315	306028-7	306960	ANVIL (Stationary Die)	1
7	—	—	—	306958	ANVIL (Stationary Die, Insulation)	1
8	2-305938-0	45314	306029-7	306961	INDENTER (Moving Die)	1
9	—	—	—	306959	INDENTER (Moving Die, Insulation)	1
10	304990	305041	—	—	FLARE PLATE, Upper	2
11	304989	305040	—	—	FLARE PLATE, Lower	1
12	—	305039	—	—	FLARE PLATE, Lower	1
13	303995	303995	9-305832-5	—	SPACER, Upper	1
14	304994	304994	9-305832-6	2-59676-3	SPACER, Lower	1
15	—	—	—	306027-6	SPACER, Insulation Adjustment	1
16	—	—	—	306027-7	SPACER, Insulation Adjustment	1
17	21041-6	21041-6	—	—	PIN, Coiled Spring	2
18	—	—	—	23911-7	WASHER, Spring	1

Figure 8 (end)

## 8. REVISION SUMMARY

Revisions to this instruction sheet per EC 0990-0057-00 include:

- Updated document to corporate requirements
- Changed repair service information in Section 7