

Fig. 1

1. INTRODUCTION

This instruction sheet (IS) covers the application and maintenance of AMP Crimping Die Assemblies 90408-1, 90249-2, 90250-1, and 90250-3. The die assemblies are used in AMP-TAPETRONIC* Machine 69875 to crimp Type II Multimate Pin and Socket contacts listed in Figure 2. For information concerning die installation and general performance of the machine, refer to AMP Customer Manual (CM) 1993.

Read these instructions thoroughly before using the die assemblies.

NOTE

All dimensions on this instruction sheet are in inches.

2. DESCRIPTION (Figure 1)

The die assemblies consist of an anvil subassembly (stationary die), and a crimper subassembly (movable die). Each die assembly features a color-coded die holding screw to facilitate mating of the dies and to match the color stripe of the contact shoulder. Crimper subassemblies are also designed with an assembly screw. See Figures 1 and 2. Anvil subassemblies 90249-2 and 90250-1 feature color dots which match the color stripe on the insulation barrel or wire barrel of the contact.

3. CRIMPING PROCEDURE

Refer to the chart in Figure 2 and select the appropriate die assembly. The color of the die holding screws (located on the crimper) must match the color stripe on the contact. Make sure the wire size, insulation diameter, and contact are compatible with the die assembly.

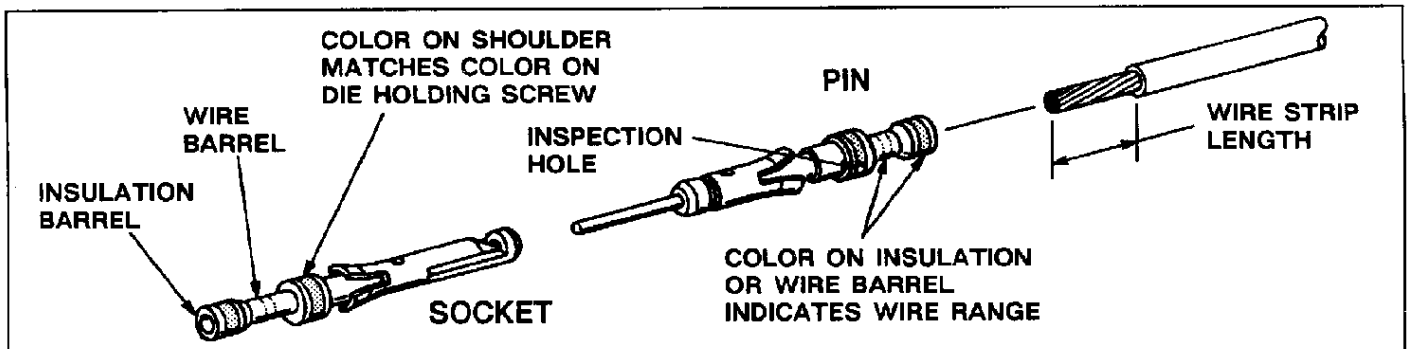

WIRE SIZE (AWG)	INSUL DIA	CONTACT PART NUMBER		COLOR STRIPE		CRIMPING DIE		WIRE STRIP LENGTH
		PIN	SOCKET	BBL	SHD	ASSY NUMBER	SCREW COLOR	
28 to 24	.048 to .065	201334	201332	Red				
		201354	201353					
	.035 to .055	201607	201609					
		201611	201613					
		201649						
		204189†						
24 to 20	.055 to .075	200334	200331	Yellow		90249-2	Red	13/64 (.203)
		200679	201328					
	.055 to .085	201330						
		204188†						
	.040 to .062	201582						
		201578	201580					
		201647						
18 to 16	No Insul Barrel	200335	200333	Blue				
		200336						
		200681						
		204274†						
(2) 18		201591	201589	—		90250-1	Blue	1/4 (.250)
		202725	202726					
14		201570	201568	Violet				
		206029†						
18 to 16		204219‡	—	Blue		90250-3		
18 to 16	.080 to .105	202507	202508	—	—	90408-1	Blue	1/4 (.250)

† SPECIAL LONG SHOULDER PINS
‡ GROUNDING PIN (LONG)

Fig. 2

NOTE

When using die assemblies 90249-2 and 90250-1, make sure the color dots (located on the anvil) match the color stripe on the contact insulation barrel or wire barrel.

1. Strip the wire to the length indicated in Figure 2. Do NOT cut or nick wire strands.

2. Install die assembly and position contacts according to the instructions packaged with the machine.
3. Insert stripped wire into contact wire barrel until wire bottoms.
4. Hold wire in place and actuate machine through a complete cycle.
5. Allow crimping dies to open fully; then remove crimped contact. Wire must be visible through contact inspection hole. See Figure 2.

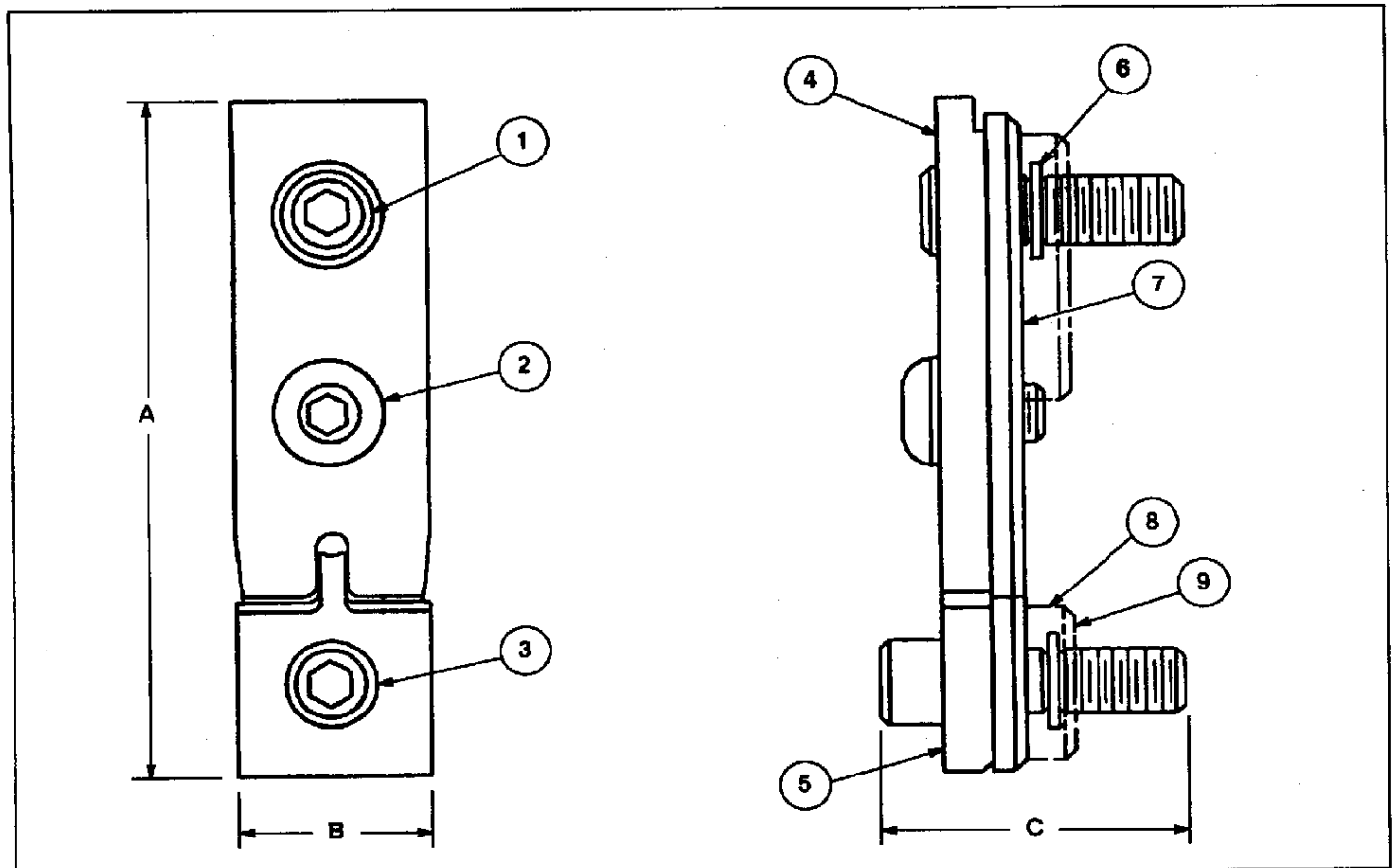

DIE SPECIFICATIONS				REPLACEMENT PARTS						
DIE NUMBER	DIMENSION			ITEM	DESCRIPTION	PART NUMBERS				QTY REQ
	A	B	C			DIE 90408-1	DIE 90249-2	DIE 90250-1	DIE 90250-3	
90249-2	2.253	.624	.860	1	SCREW, Die Holding	59781-4	59781-4	2-59781-8	1-59781-2	1
90250-1	2.223	.624	.815	2	SCREW, Assembly	3-59577-6	3-59577-6	3-59577-6	—	1
90250-3	2.223	.624	.752	3	SCREW, Die Holding	1-59781-3	59781-7	1-59781-3	2-59781-7	1
90408-1	2.212	.624	.625	4	CRIMPER, Insulation	312344-1	125784-2	125785-1	—	1
				5	ANVIL, Insulation	312345-1	125783-3	125783-2	—	1
				6	RING, Retaining	1-21046-3	1-21046-3	1-21046-3	1-21046-3	2
				7	CRIMPER, Wire	125782-7	125782-4	125782-3	312310-1	1
				8	ANVIL, Wire	125781-7	125781-4	125781-3	125781-3	1
				9	SPACER, Lower	—	—	—	1-125181-2	1
WEIGHT										
Approx 5 oz										

Fig. 3

NOTE

Extensive use of die assembly 90249-2 may cause contacts to stick in the upper die. If you experience this problem, replace the probe head on the machine with a stripper block (313450-1). For detailed information on the stripper block, contact the AMP Customer Hotline, or your local AMP Field Representative.

4. DIE INSPECTION

Die Assemblies 90408-1, 90249-2, 90250-1, and 90250-3 are inspected before shipment. AMP recommends that the dies be inspected immediately upon arrival at your facility to ensure that the dies conform to the dimensions provided in Figure 3, and that the dies have not been damaged during shipment.

5. MAINTENANCE/QUALITY CONTROL

A. Daily Maintenance

It is recommended that each operator of the dies be responsible for the following three steps of daily maintenance:

1. Remove dust, dirt, and other contaminants with a clean brush, or a soft, lint-free cloth. Do NOT use objects that could damage the dies.
2. Make certain the dies are protected with a THIN coat of any good SAE No. 20 motor oil. DO NOT OIL EXCESSIVELY.
3. When the dies are not in use, mate and store them in a clean, dry area.

B. Periodic Inspection

Regular inspections should be performed by quality control personnel. A record of scheduled inspections should remain with the dies and/or be supplied to supervisory personnel responsible for the dies. Though recommendations call for at least one inspection a month, the inspection frequency should be based on the amount of use, ambient working conditions, operator training and skill, and established company standards. These inspections should be performed in the following sequence:

B-1. Visual Inspection

1. Remove all lubrication and accumulated film by immersing the dies in a suitable commercial degreaser that will not affect paint or plastic material.
2. Make sure all die holding screws, retaining rings, and die components are in place. Refer to the parts listed in Figure 3 if replacements are needed.
3. Check components for wear. Remove and replace worn components.
4. Inspect the crimp area for flattened, chipped, cracked, worn, or broken areas. If damage is evident, the dies must be repaired before returning them to service (see Paragraph 6, DIE REPLACEMENT AND REPAIR).

B-2. Gaging the Crimping Chamber

This inspection requires the use of a plug gage conforming to the diameters in Figure 4. AMP does not manufacture or market these gages.

Proceed as follows:

1. Mate the dies until it is evident that they have bottomed. Hold the dies in this position with a pressure of approximately 10 psi.

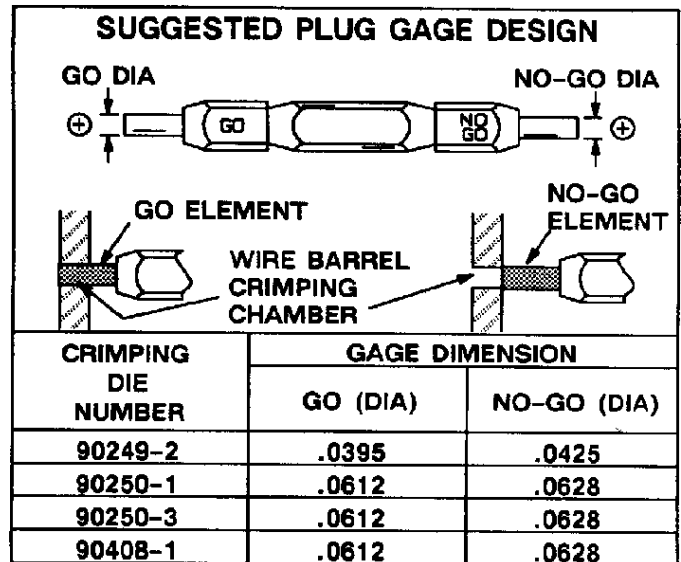

Fig. 4

2. Align the GO element with the wire barrel crimping chamber. Push element straight into the crimping chamber without using force. The GO element must pass completely through the crimping chamber as shown in Figure 4.

3. Align the NO-GO element and try to insert it straight into the same crimping chamber. The NO-GO element may start entry but must not pass completely through, as shown in Figure 4.

If the crimping chamber conforms to the gage inspection, the dies are considered dimensionally correct and should be lubricated with a THIN coat of SAE No. 20 motor oil. If not, the dies must be repaired before returning them to service.

For additional information concerning the use of a plug gage, refer to AMP Instruction Sheet IS 7424.

6. DIE REPLACEMENT AND REPAIR

The parts listed in Figure 3 are customer-replaceable parts. A complete inventory should be stocked and controlled to prevent lost time when replacement of parts is necessary. Replacement dies can be purchased from:

AMP Incorporated
P.O. 3608
Harrisburg, PA 17105-3608

or a wholly owned subsidiary of AMP Incorporated.

The dies can also be returned to AMP for evaluation and repair. Send the dies with a written description of the problem to:

AMP Incorporated
Customer Repair
1523 North 4th Street
Harrisburg, PA 17102-1604