

### PROPER USE GUIDELINES

Cumulative Trauma Disorders can result from the prolonged use of manually powered hand tools. AMP hand tools are intended for occasional use and low volume applications. AMP offers a wide selection of powered application equipment for extended-use, production operations.

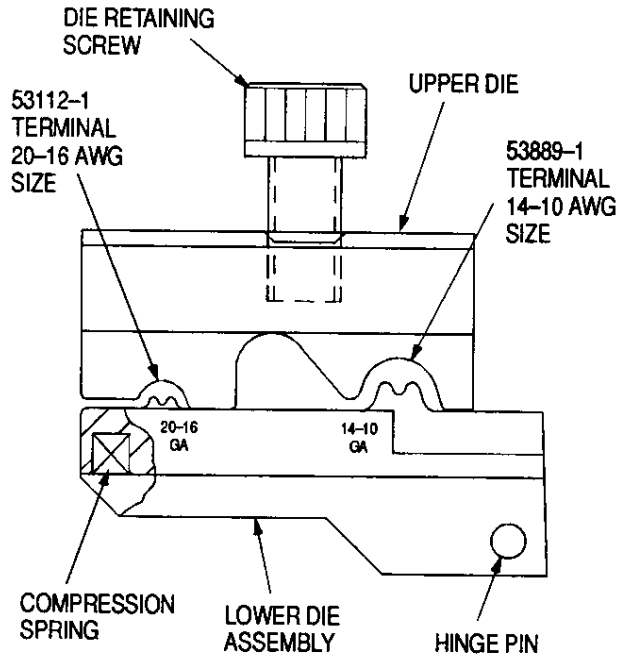

Figure 1

cad

### 1. INTRODUCTION

This instruction sheet covers application and maintenance procedures for AMP Crimping Die assembly 58507-1 which is used in AMP Platform Die Hand Tool 58078-5. The die assembly crimps relay tab terminals 53889-1 and 53112-1.

Read these instructions carefully before inserting any die assembly or crimping any terminals.

#### NOTE

All dimensions on this document are in metric units [with U.S. customary units in brackets].

### 2. DESCRIPTION

The assembly consist of an upper die, a lower die, a hinge pin, compression spring, and retaining screw. The wire range and terminal crimp sections are shown in Figure 1.

### 3. INSTALLING CRIMPING DIE ASSEMBLY

1. Squeeze tool handles together until they bottom, then allow them to open freely.

2. Insert compression spring in lower die. See Figure 2.

3. Align lower die with lower platform and position die against die stop.

4. Insert hinge pin through lower die into platform threaded hole. Tighten hinge pin until it bottoms, then turn pin counterclockwise 1/8 of a turn (45°).

5. Position upper die on the upper platform of the tool, and thread die retaining screw through mounting hole in top of tool and upper die until it is snug but not tight.

6. While guiding upper die into alignment with lower die, slowly close tool handles until dies bottom. Tighten die retaining screw until it is secure.

7. Squeeze handles together until ratchet releases. Allow handles to open fully, and tool is now ready for use.

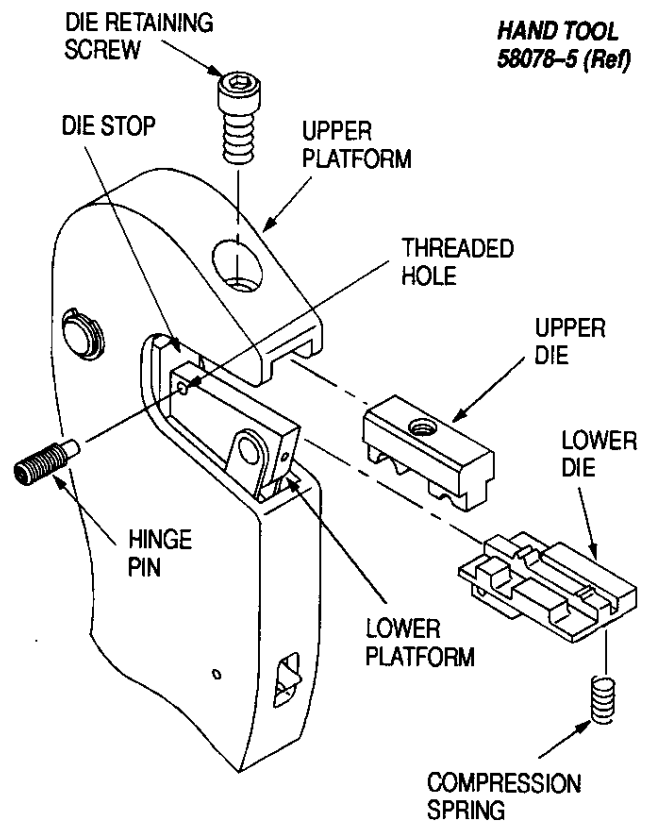

HAND TOOL  
58078-5 (Ref)

Figure 2

cad

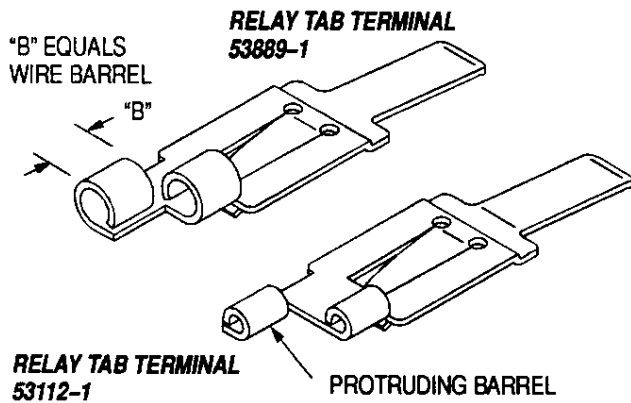

TAB NUMBER	WIRE SIZE	WIRE STRIP LENGTH	
		MINIMUM	MAXIMUM
53112-1	20-16	5.56	6.35
53889-1	14-10	[.219]	[.250]

Figure 3 cad

**4. CRIMPING PROCEDURE**

The following instructions are the same for both relay tab terminals 53112-1 and 53889-1.

1. Strip wire to dimension listed in Figure 3.
2. Squeeze handles until ratchet releases and allow handles to open fully.
3. The protruding barrel is crimped first on both terminals. Place protruding wire barrel in upper die crimp section;

4. Close handles, aligning the center of wire barrel on center of lower die crimp section, until tab is held firmly in place. Do not deform wire barrel.
5. Insert stripped wire into wire barrel until end of wire is flush or extended slightly beyond end of wire barrel.
6. To complete crimp, close handles until ratchet releases; dies will bottom surface shown in Figure 5. Allow handles to open; crimped item may be removed
7. To crimp the other wire barrel, repeat steps 3 through 6 except that the remaining wire barrel is positioned in upper die crimp section.

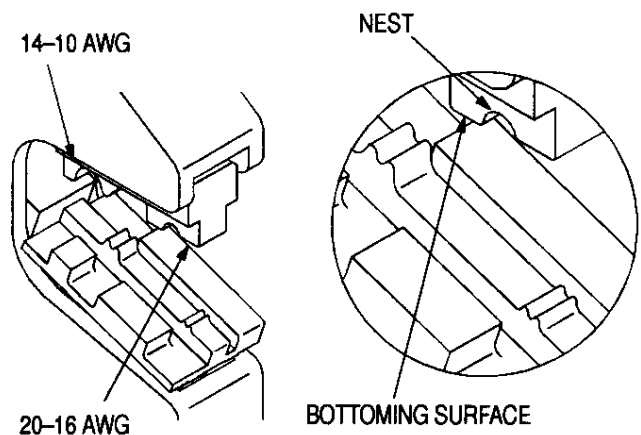

Figure 5 cad

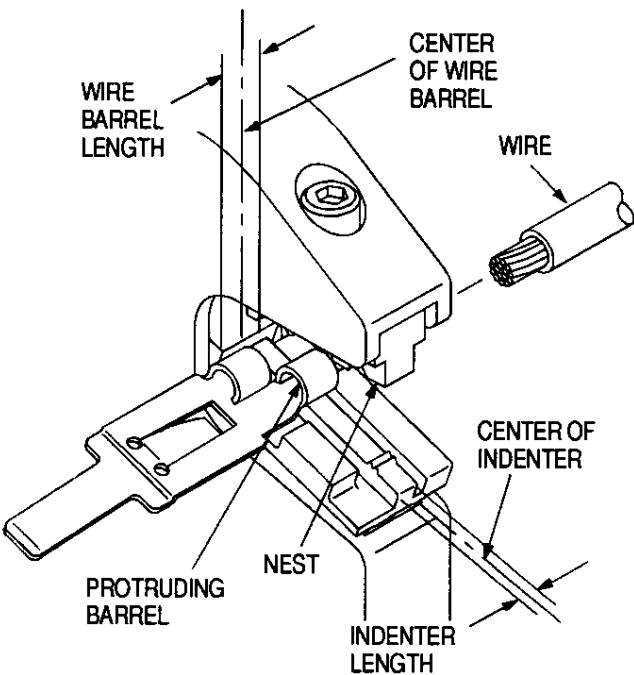

Figure 4 cad

**5. CRIMP INSPECTION**

Inspect crimped relay tab terminals, by checking the features described in Figure 6. Use only the tabs that meet conditions shown in the "ACCEPT" column. "REJECT" terminals can be avoided through careful use of instructions in Section 4 and by performing regular tool maintenance as instructed in Section 6.

**6. MAINTENANCE/INSPECTION PROCEDURE**

AMP recommends that a maintenance/inspection program be performed periodically to ensure dependable and uniform terminations. Inspect tools at least once per month. Frequency of inspection may be adjusted to suit your requirements through experience. Frequency of inspection depends upon:

1. The care, amount of use, and handling of the tool.
2. The degree of operator skill.
3. The presence of abnormal amounts of dust and dirt.
4. Your own established standards.

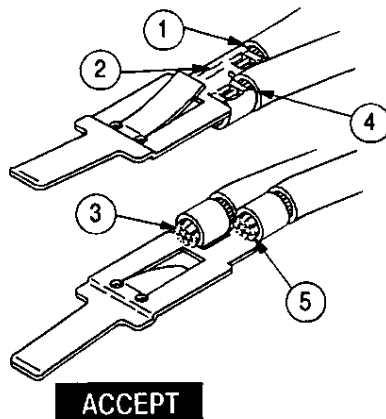

- ACCEPT**
- ① Crimp centered. Crimp may be off center BUT NOT OFF END OF WIRE BARREL.
  - ② Wire size being used matches wire size stamped on tool and relay tab terminal.
  - ③ End of wire is flush with or extends slightly beyond end of wire barrel.
  - ④ Insulation does not enter wire barrel.
  - ⑤ No nicked or missing strands.

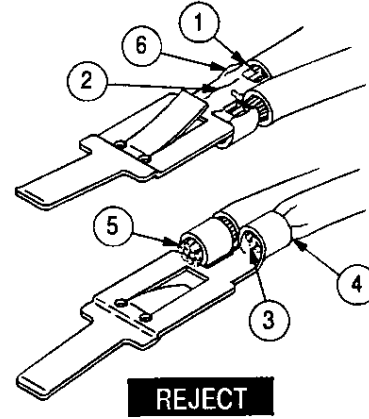

- REJECT**
- ① Crimped off end of tab wire barrel.
  - ② Wire size being used does not match wire size stamped on tool and relay tab terminal.
  - ③ Wire not inserted far enough in wire barrel. End of wire must be flush with or extend slightly beyond end of wire barrel.
  - ④ Insulation entered wire barrel.
  - ⑤ Nicked or missing strands.
  - ⑥ Excessive flash. Check for damaged dies.

Figure 6

cad

All crimping tools are thoroughly inspected before shipping. Since there is a possibility of tool damage in shipment, inspect new tools in accordance with this section when received in your plant.

### 6.1. Cleaning

The tool should be immersed in a reliable commercial degreasing compound to remove accumulated dirt, grease, and foreign matter.

### 6.2. Visual Inspection

Visually inspect tool for missing pins or retaining rings, then operate tool and note the return action of spring-loaded handles. If parts are missing or defective, refer to Figure 10 for customer replaceable parts.

Visually inspect die closure surfaces for broken, pitted, or chipped conditions. Although dies may gage within permissible limits, worn or damaged die closure surfaces are objectionable and can affect the quality of the crimp. Examples of possible damaged die closure surfaces are shown in Figure 7.

### 6.3. Lubrication

Lubricate all pins, pivot points, and bearing surfaces with a good SAE No. 20 motor oil as follows:

- Tools used in daily production – lubricate daily.
- Tools used daily (occasional) – lubricate weekly.
- Tools used weekly – lubricate monthly.

Wipe excess oil from tool, particularly from crimping surfaces. Oil transferred from the crimping surfaces onto certain terminations may affect the electrical characteristics of an application.

### 6.4. Gaging the Crimping Chamber

This inspection requires the use of a plug gage conforming to the dimensions shown in Figure 8. AMP does not manufacture or market these gages.

Proceed as follows:

1. Close handles to bottom dies and maintain slight pressure on handles for inspection.

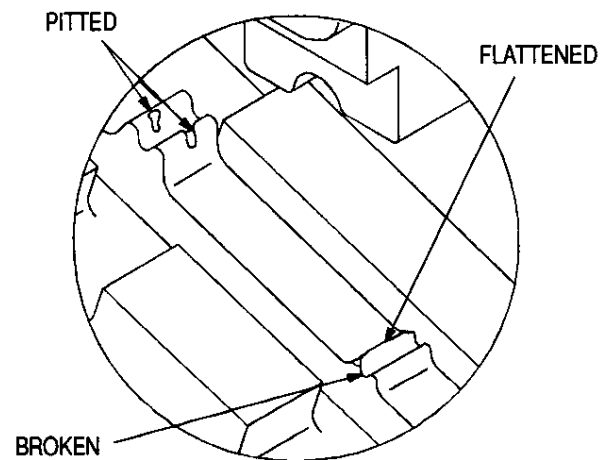
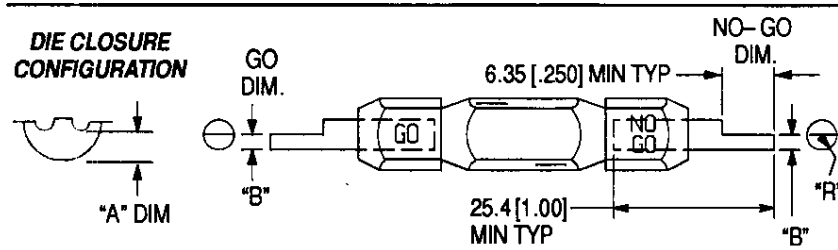

Figure 7

cad

### SUGGESTED PLUG GAGE DESIGN



CRIMPING SECTION (WIRE SIZE)	DIE CLOSURE DIMENSIONS "A"•		GAGE ELEMENT† DIMENSIONS "B"		RADIUS "R"
	GO	NO-GO	GO	NO-GO	
20-16	1.016 [.0400]	1.143 [.0450]	1.016-1.023 [.0400-.0403]	1.166-1.168 [.0459-.0460]	1.52 [.060]
14-10	1.461 [.0575]	1.613 [.0635]	1.461-1.468 [.0575-.0578]	1.610-1.613 [.0634-.0635]	2.39 [.094]

• DIE CLOSURE DIMENSIONS APPLY WHEN JAWS ARE BOTTOMED BUT NOT UNDER PRESSURE.  
† MATERIAL - TOOL STEEL.

Figure 8

200-001E

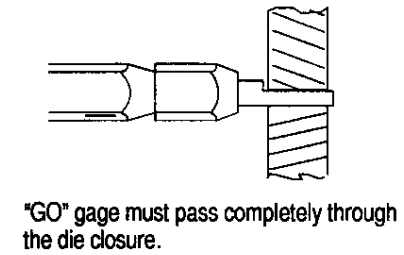

"GO" gage must pass completely through the die closure.

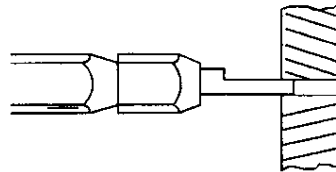

"NO-GO" gage may enter partially, but must not pass completely through the die closure.

Figure 9

200-001E

2. Align the GO element with the wire barrel crimping chamber. Push the element straight into the crimping chamber without using force. The GO element must pass completely through the crimping chamber, as shown in Figure 9.

3. Align the NO-GO element and try to insert it straight into the same crimping chamber. The NO-GO element may start entry but must not pass completely through, as shown in Figure 9.

If the crimping chamber conforms to the gage inspection, the dies are considered dimensionally correct and should be lubricated with a THIN coat of any good SAE No. 20 motor oil. If not, the dies must be repaired before returning them to service (see Section 7, REPLACEMENT AND REPAIR).

For additional information concerning the use of a plug gage refer to AMP instruction sheet 408-7424.

## 7. REPLACEMENT AND REPAIR

The parts listed in Figure 10 are customer-replaceable. A complete inventory can be stocked and controlled to prevent lost time when replacement of parts is necessary. Order replacement parts through your AMP representative, or call 1-800-526-5142, or send a facsimile of your purchase order to 1-717-986-7605, or write to:

CUSTOMER SERVICE (38-35)  
AMP INCORPORATED  
P.O. BOX 3608  
HARRISBURG, PA 17105-3608

Dies may also be returned to AMP for evaluation and repair. For repairs, send dies, with a written description of the problem, to:

CUSTOMER REPAIR (01-12)  
AMP INCORPORATED  
1523 NORTH 4TH STREET  
HARRISBURG, PA 17102-1604

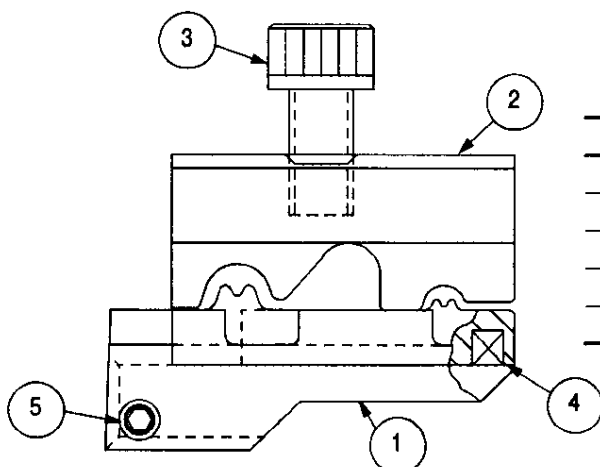

ITEM	PART NUMBER	DESCRIPTION	QTY
1	90786-1	DIE, Lower	1
2	90785-1	DIE, Upper	1
3	3-21000-4	SCREW, SHC 10-32 UNF	1
4	4-23147-2	SPRING, Compression	1
5	354789-1	PIN, Hinge	1

Figure 10

cad