

| CRIMPING DIE PART NO. | TERMINAL COLOR CODE | WIRE SIZE (AWG) | WIRE STRIP LENGTH |              |
|-----------------------|---------------------|-----------------|-------------------|--------------|
|                       |                     |                 | MINIMUM           | MAXIMUM      |
| 68247-1               | Red                 | 8               | 11.51 [.453]      | 12.29 [.484] |
| 68248-1               | Blue                | 6               | 15.47 [.609]      | 16.26 [.640] |
| 1213098-1             | Yellow              | 4               | 15.47 [.609]      | 16.26 [.640] |

Figure 1

## 1. INTRODUCTION

Crimping Dies 68247-1, 68248-1, and 1213098-1 are used with AMP-TAPETRONIC\* Crimping Machine 68250-1. The dies crimp PLASTI-GRIP\* Terminals onto stranded wire sizes 8 through 4 AWG. Refer to Figure 1 to ensure compatibility of crimping die and wire size.

For detailed information relative to tooling adjustment, tape loading, etc., refer to the Customer Manual (409-2586) packaged with the machine.

**NOTE** All dimensions in this document are in millimeters [with inches in brackets]. Illustrations are for reference only and are not drawn to scale.

Reasons for reissue of this instruction sheet are provided in Section 8, REVISION SUMMARY.

## 2. DESCRIPTION

Each crimping die consists of a stationary die, a moving die, and two die holding screws. The applicable wire size is marked on each die. When mated, the dies form a crimping chamber.

## 3. DIE INSTALLATION AND REMOVAL



To avoid personal injury, ALWAYS disconnect machine from power supply when performing adjustment, die installation or removal, and machine maintenance. Always keep guards and covers in place during normal machine operation.

### 3.1. Installation

Refer to the table in Figure 1 and select the crimping die for the wire size being used. Wire size displayed on dies must match wire size stamped under terminal tongue.

1. Turn off main power switch and disconnect machine from power supply.
2. Remove front applicator guard, then depress terminal extractor and pivot it away from crimping die holder (see Figure 2).
3. With tape release lever UP, insert moving die (upper) into die holder and tighten holding screw.
4. Insert stationary die (lower) into die holder and tighten holding screw.
5. Pivot terminal extractor to vertical position and install applicator guard.
6. Lower tape release lever.
7. Connect machine to power supply and turn on main power switch.

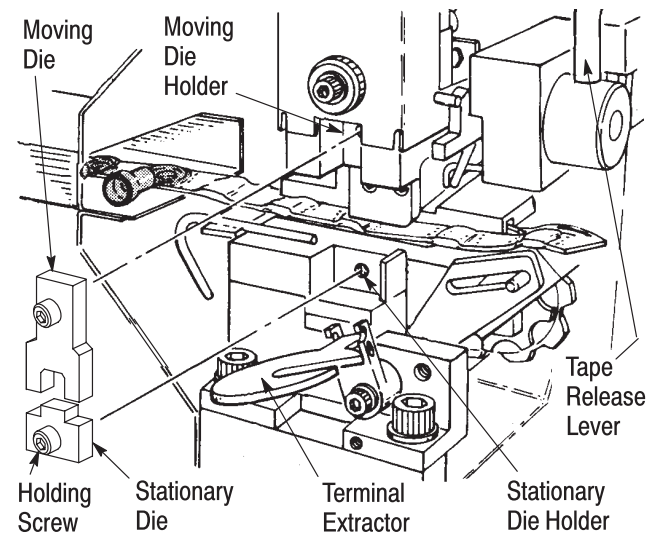

Figure 2

### 3.2. Removal

1. Turn off main power switch and disconnect machine from power supply.

2. Remove front applicator guard, then depress terminal extractor and pivot it away from crimping die holder (see Figure 2).

3. With tape release lever UP, remove holding screws and dies.

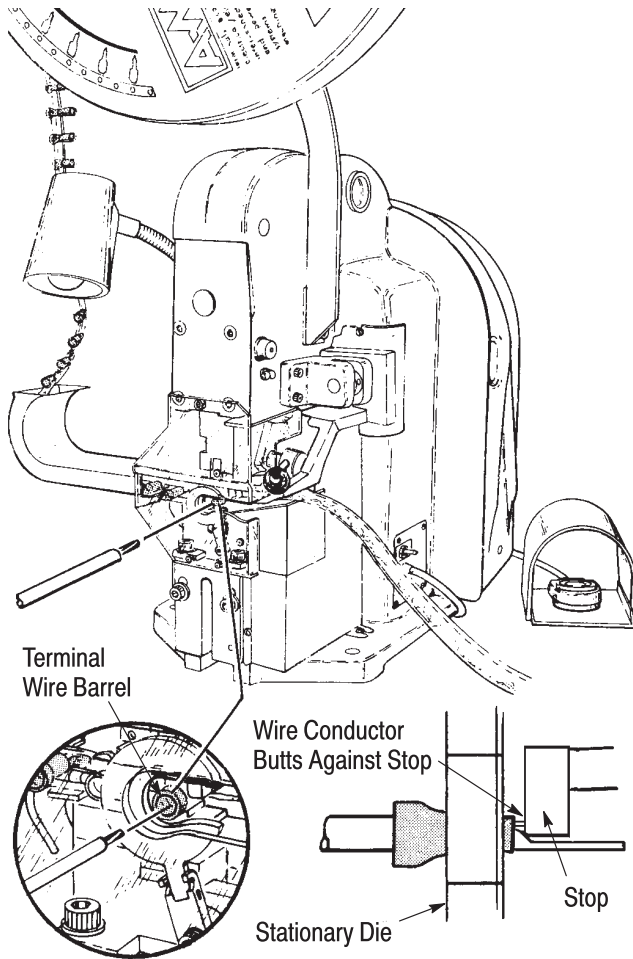

Figure 3

#### 4. CRIMPING PROCEDURE

1. Strip wire to the dimensions listed in Figure 1. Do not cut or nick the wire strands.
2. Place main power switch in the ON position and be sure tape release lever is lowered.
3. Insert stripped wire into terminal wire barrel until wire conductor butts against the stop. See Figure 3.
4. Holding wire in place, depress and release foot switch. The machine will cycle and crimp the terminal.

5. Remove crimped terminal.

6. Inspect the crimp according to Section 5.

#### 5. CRIMP INSPECTION

Inspect crimped terminals by checking the features described in Figure 4. Use only the terminals that meet the conditions shown in the "ACCEPT" column.

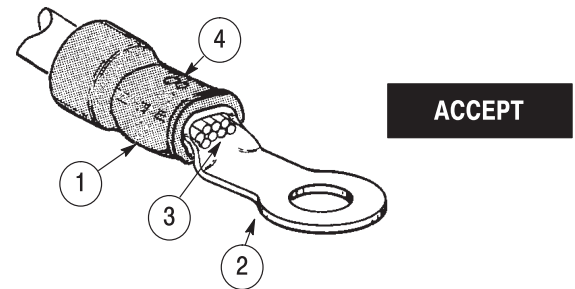

- 1 The crimp is centered on the wire barrel. Crimp may be slightly off center but NOT off end of wire barrel.
- 2 The wire size (AWG) being used matches the wire size stamped under the terminal tongue and on the dies.
- 3 The wire conductor is flush with or extends beyond the end of the terminal wire barrel.
- 4 The embossed wire size matches the wire size stamped under the terminal tongue.

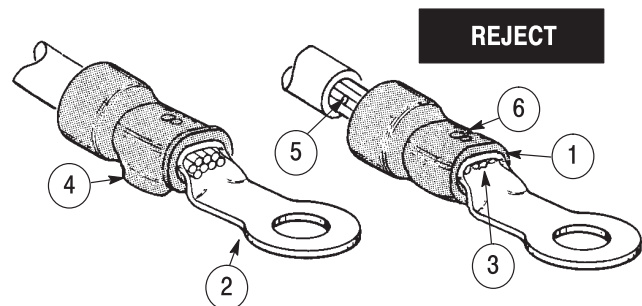

- 1 The crimp is off the end of the terminal wire barrel. Refer to Customer Manual 409-2586 for crimp location adjustment.
- 2 The wire size (AWG) being used does not match the wire size stamped under the terminal tongue or on the dies.
- 3 The wire conductor is not inserted far enough into terminal. End of conductor must be flush with or extend beyond end of terminal wire barrel.
- 4 Excessive flash on crimped wire barrel indicates wrong wire, terminal, or die combination was used or dies were damaged.
- 5 Nicked or missing wire conductor strands.
- 6 The embossed wire size does not match the wire size stamped under the terminal tongue.

Figure 4

**6. MAINTENANCE/INSPECTION**

Each crimping die is thoroughly inspected before packaging. Since there is a possibility of damage during shipment, the crimping die should be inspected immediately upon arrival at your facility.

Regular inspections should be performed by quality control personnel. A record of scheduled inspections should remain with the dies and/or be supplied to supervisory personnel responsible for the dies. Though recommendations call for at least one inspection a month, the inspection frequency should be based on the amount of use, ambient working conditions, operator training and skill, and established company standards.

**6.1. Daily Maintenance**

It is recommended that each operator of the dies be made aware of—and responsible for—the following steps of daily maintenance:

1. Remove dust, dirt, and other contaminants with a clean brush, or a soft, lint-free cloth. Do NOT use objects that could damage the dies.
2. Make certain the dies are protected with a THIN coat of any good SAE 20 motor oil. Do not oil excessively.
3. When the dies are not in use, mate them and store in a clean, dry area.

**6.2. Visual Inspection**

Visually inspect the die closure surfaces for broken, chipped, or pitted conditions. Although dies may gage within permissible limits, worn or damaged die closure surfaces can affect the quality of the crimp. Examples of possible damaged die surfaces are shown in Figure 5.

**6.3. Gaging the Crimping Chamber**

The die closure inspection is accomplished using plug gages. A suggested gage design and the GO and NO-GO diameters of the plug gage elements are shown in Figure 6. The following procedure is recommended for inspecting the die closures.

1. Mate the dies until it is evident that they have bottomed. Hold the dies in this position.
2. Align the GO element with the crimping chamber. Push element straight into the crimping chamber without using force. The GO element must pass completely through the crimping chamber as shown in Figure 7.
3. Align the NO-GO element and try to insert it straight into the crimping chamber. The NO-GO element may start entry but must not pass completely through as shown in Figure 7.

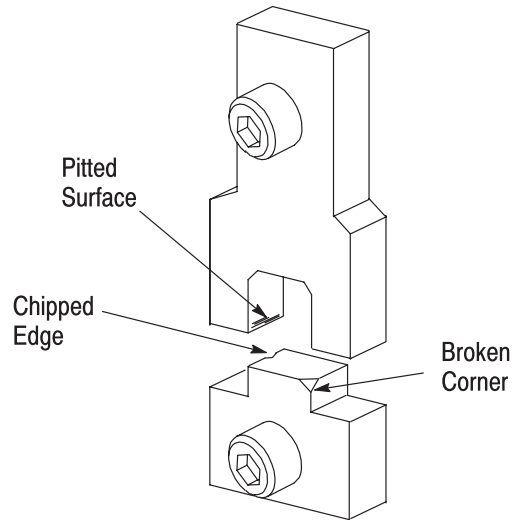
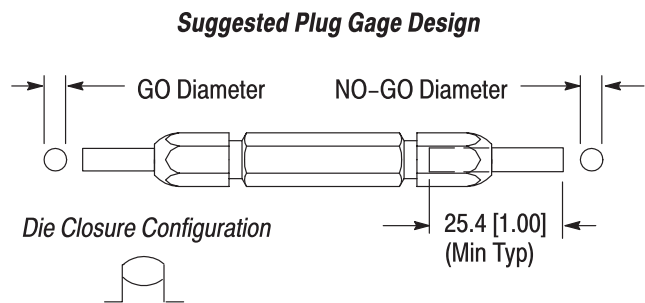

Figure 5

3. Align the NO-GO element and try to insert it straight into the crimping chamber. The NO-GO element may start entry but must not pass completely through as shown in Figure 7.

If the crimping chamber conforms to the gage inspection, the crimping die is considered dimensionally correct and should be lubricated with a THIN coat of SAE 20 motor oil. If not, the dies must be repaired before returning them to service (see Section 7, REPLACEMENT AND REPAIR).

For additional information concerning the use of a plug gage, refer to Instruction Sheet 408-7424.



| CRIMPING DIE | GAGE ELEMENT DIAMETER        |                              |
|--------------|------------------------------|------------------------------|
|              | GO                           | NO-GO                        |
| 68247-1      | 5.588-5.596<br>[.2200-.2203] | 5.789-5.791<br>[.2279-.2280] |
| 68248-1      | 6.325-6.332<br>[.2490-.2493] | 6.525-6.528<br>[.2569-.2570] |
| 1213098-1    | 7.315-7.323<br>[.2880-.2883] | 7.417-7.419<br>[.2920-.2921] |

Figure 6

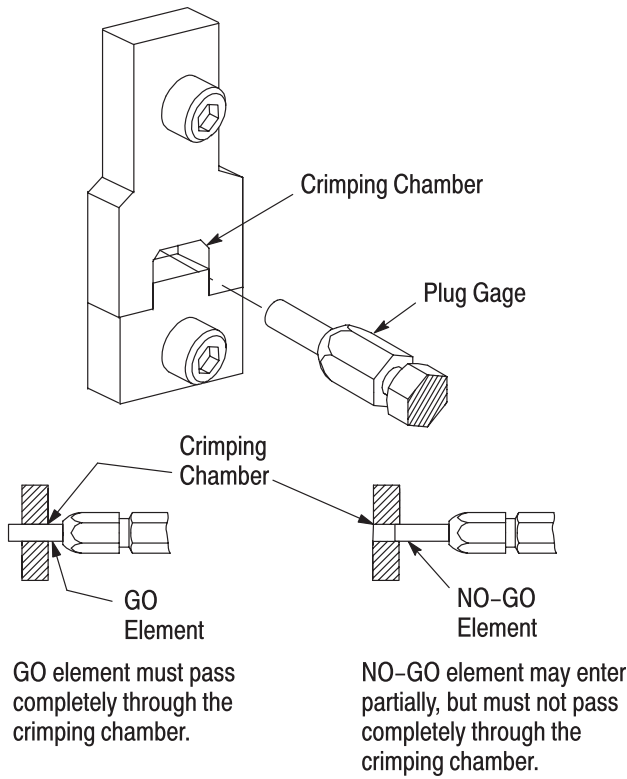

Figure 7

### 7. REPLACEMENT AND REPAIR

The parts listed in Figure 8 are customer-replaceable.

A complete inventory of parts can be stocked and controlled to prevent lost time when replacement of parts is necessary. Order replacement parts through your Tyco Electronics Representative, or call 1-800-526-5142, or send a facsimile of your purchase order to 1-717-986-7605, or write to:

CUSTOMER SERVICE (38-35)  
 TYCO ELECTRONICS CORPORATION  
 P.O. BOX 3608  
 HARRISBURG, PA 17105-3608

Dies may be returned for evaluation and repair. For die repair service, contact a Tyco Electronics Representative at 1-800-526-5136.

### 8. REVISION SUMMARY

- Updated document to corporate requirements
- New format

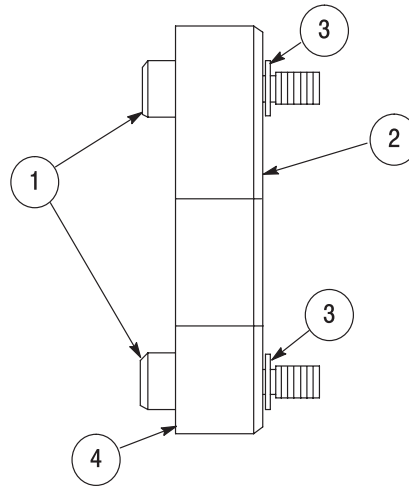

| ITEM | CRIMPING DIE PART NUMBER |           |           | DESCRIPTION        | QUANTITY PER ASSEMBLY |
|------|--------------------------|-----------|-----------|--------------------|-----------------------|
|      | 68247-1                  | 68248-1   | 1213098-1 |                    |                       |
| 1    | 3-59781-0                | 3-59781-1 | 59781-6   | SCREW, Die Holding | 2                     |
| 2    | 308245-1                 | 308245-2  | 1213067-1 | DIE, Moving        | 1                     |
| 3    | 1-21046-3                | 1-21046-3 | 1-21046-3 | RING, Retaining    | 2                     |
| 4    | 308246-1                 | 308246-2  | 1213066-1 | DIE, Stationary    | 1                     |

Figure 8