

Figure 1

## 1. INTRODUCTION

Crimping Heads 1-576778-0, 1-576779-0, 1-576780-0, 1-576781-0, and 1-576782-0 are designed to crimp PIDG STRATO-THERM Terminals onto solid or stranded copper wire size 24-14 AWG. Refer to Figure 2. The crimping heads are used with Heavy Head Battery Powered Hand Tool Kits 1901235-[ ].

### NOTE



The crimping heads can also be used with the 626 Heavy Head Pneumatic Tool Adapter 525432-1.

This instruction sheet provides recommended procedures for wire preparation, crimping head installation, crimping, and maintenance and inspection. For information concerning tool setup and operation, refer to Customer Manual 409-10068 packaged with the battery tool kit.

### NOTE



Dimensions on this instruction sheet are in millimeters [with inches in brackets]. Figures and illustrations are for identification only and are not drawn to scale.

Reasons for reissue are provided in Section 8, REVISION SUMMARY.

## 2. DESCRIPTION

Each crimping head features a head containing two stationary crimping dies (anvils) and two movable crimping dies (indenters), a locator, an insulation crimping adjustment pin, and a battery powered crimp tool. See Figure 1.

When closed, the crimping dies form one crimping chamber with two sections: an insulation barrel section and a wire barrel section. The insulation barrel section crimps the terminal onto the wire insulation and, simultaneously, the wire barrel section crimps the terminal wire barrel onto the stripped wire. The locator positions the terminal in the crimping chamber. The insulation crimping adjustment pin is used to regulate the height of the insulation crimp.

Using Heavy Head Battery Powered Hand Tool Kits 1901235-3 or -4 will ensure full crimping of the terminal. The rams on tools 1901235-1 and -2 can be retracted before the terminal is fully crimped.

**3. INSTALLATION AND REMOVAL OF CRIMPING HEADS**

**CAUTION**  Do not operate the tool without the HHHT adapter installed. Damage to the ram or seals can result.

**CAUTION**  Do not operate the tool without a hand tool crimp head installed. Damage to the adapter can result.

Battery Powered Crimp Tool Kit 1901235-[ ] with HHHT Adapter comes with the HHHT adapter already installed on the battery powered hand tool. The only installation required is the installation of the crimping heads.

**DANGER**  To avoid personal injury, be sure to exercise extreme caution when handling the crimp tool. Remove the battery before installing or removing the crimping heads.

**3.1. Installation of Crimping Heads**

As supplied, the adapter has three quick-release pins installed (Figure 1). The two outer pins will be used to secure the links of the crimp head (exposed portion of the crimp head) to the adapter. The center pin will be used to secure the movable die of the crimp head to the ram of the adapter.

These pins must be removed prior to installing the crimping head.

1. Remove the quick-release pins, described above.
2. Insert the exposed portion of the crimp head into the adapter cavity. See Figure 1.
3. Insert the two outer quick-release pins through the holes in the adapter, and through the holes in the links of the crimping head.

**NOTE**  The quick-release pins will “snap” into position when they are properly inserted.

4. Insert the center quick-release pin into the adapter and through the holes in the ram and the moveable die of the crimp head.

**NOTE**  The quick-release pin will “snap” into position when it is properly inserted.

**3.2. Removal of Crimping Heads**

**DANGER**  To avoid personal injury, remove the battery before removing the crimping heads.

To remove the crimping head, it will be necessary to remove the quick-release pins and the crimp head from the battery powered crimp tool.

HEAD PART NUMBER	WIRE SIZE (AWG)	DOT CODE	HANDLE COLOR CODE	TERMINAL COLOR CODE		STRIP LENGTH	
				HIGH TEMP.	LOW TEMP.	Min.	Max.
1-576778-0	24-22	2 Dots	1 Handle Black 1 Handle Brown	Brown	Black	5.56 [.219]	6.35 [.250]
1-576779-0	20	1 Dot	1 Handle Gray 1 Handle Purple	Gray	Purple (With Black Stripe)	5.56 [.219]	6.35 [.250]
1-576780-0	18	2 Dots	1 Handle Orange 1 Handle Black	Orange	Orange (With Black Stripe)	5.56 [.219]	6.35 [.250]
1-576781-0	16	1 Dot	2 Handles Orange	Orange	Orange (With Black Stripe)	5.56 [.219]	6.35 [.250]
1-576782-0	14	2 Dots	1 Handle White 1 Handle Black	White	White (With Black Stripe)	5.56 [.219]	6.35 [.250]

Figure 2

**4. CRIMPING PROCEDURE**

**NOTE** Refer to Section 5 for information on the insulation crimp adjustment.

Refer to Figure 3 and the following steps for terminal crimping procedures.

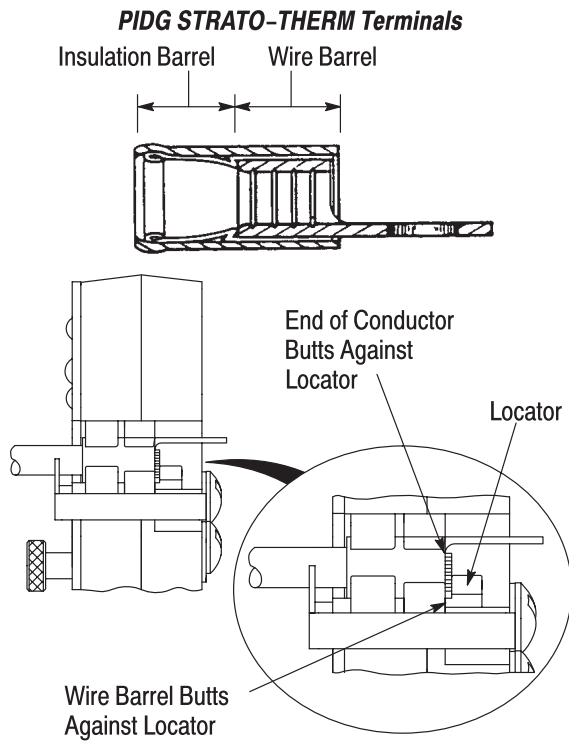

Figure 3

1. Strip the wire to the dimension provided in Figure 2, being careful to avoid nicking or damaging the conductor(s).

**CAUTION** Do NOT use wire with nicked or missing conductors.

**NOTE** Make sure terminal insulation color code matches tool handle color.

2. Depress the trigger to advance the moving ram. This action closes the crimp jaws in order to hold the terminal in place. DO NOT deform the wire barrel.

3. Insert stripped wire into terminal until the end of the conductor butts against the locator as shown in Figure 3.

**NOTE** Do NOT allow wire insulation to enter the terminal wire barrel.

4. Activate the tool to complete the crimp. The crimp tool automatically returns to the first position of the cycle when the crimp is complete.

5. Observe the dot code on the finished crimp to ensure that the correct terminal and crimping head combination was used. See Figure 2.

6. Refer to Section 4 and Figure 4 for terminal crimp inspection procedure.

**5. CRIMP INSPECTION**

Inspect crimped terminals by checking the features described in Figure 4. Terminals, not meeting the described conditions should NOT Be used.

**6. INSULATION CRIMP ADJUSTMENTS**

The insulation crimping section of the crimping head has three positions: 1 (tight), 2 (medium), and 3 (loose). To adjust the section:

1. Insert the insulation crimp adjustment pins into the No. 3 position. Refer to Figure 1.

2. Place the terminal into the crimping jaws as shown in Figure 3.

3. Insert the UNSTRIPPED wire into ONLY the insulation barrel (refer to Figure 3) portion of the terminal.

4. Close the tool to complete the crimp.

5. Removed the crimped terminal and check the insulation crimp by bending the wire back and forth once. The terminal should retain its grip on the wire insulation. If the wire pulls out, set the insulation crimp adjustment pins to the next higher position (No. 2).

6. Perform another crimp and repeat the adjustment as necessary until the correct insulation grip is attained. Do not use a tighter setting than required.

**CAUTION** Make sure that both insulation crimp adjustment pins are in the same position.

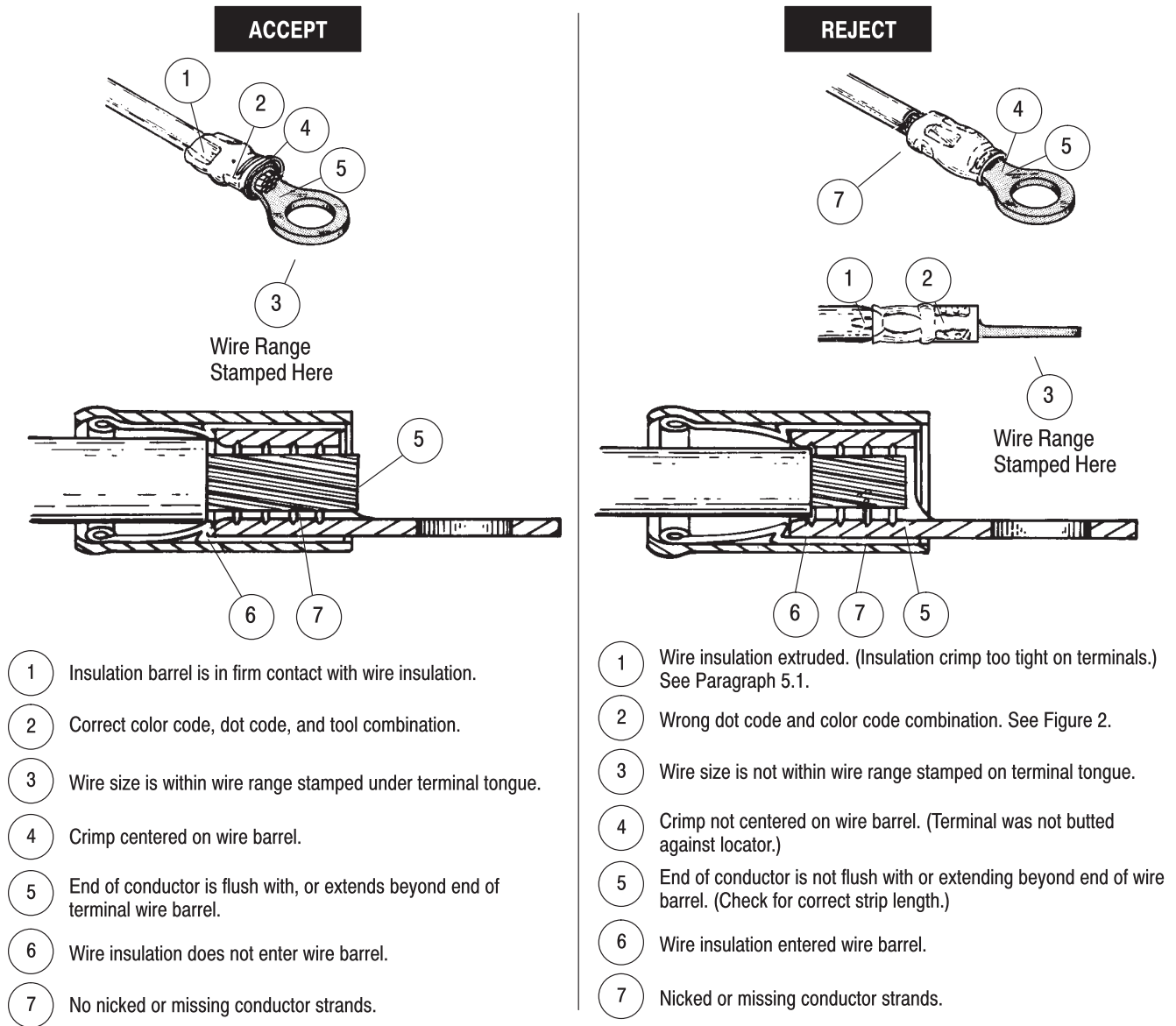

Figure 4

## 7. MAINTENANCE AND INSPECTION PROCEDURE

Tyco Electronics recommends that a maintenance and inspection program be performed periodically to ensure dependable and uniform terminations. Though recommendations call for at least one inspection a month, frequency of inspection depends on:

1. The care, amount of use, and handling of the hand tool.
2. The presence of abnormal amounts of dust and dirt.
3. The degree of operator skill.
4. Your own established standards.

The crimping head is inspected before being shipped; however, Tyco Electronics recommends that the tool

be inspected immediately upon arrival to ensure that the tool has not been damaged during shipment.

### 7.1. Daily Maintenance

1. Crimping head should be immersed in a reliable commercial degreasing compound to remove accumulated dirt, grease, and foreign matter. When degreasing compound is not available, head may be wiped clean with a soft, lint-free cloth. Do NOT use hard or abrasive objects that could damage the crimping head.
2. Make certain that the retaining pins are in place and that they are secured with retaining rings.
3. All pins, pivot points, and bearing surfaces should be protected with a THIN coat of any good SAE 20 motor oil. Do not oil excessively.

**7.2. Periodic Inspection**

**A. Lubrication**

Lubricate all pins, pivot points, and bearing surfaces with SAE 20 motor oil as follows:

- Tool used in daily production – lubricate daily
- Tool used daily (occasional) – lubricate weekly
- Tool used weekly – lubricate monthly

Wipe excess oil from tool, particularly from crimping area. Oil transferred from the crimping area onto certain terminations may affect the electrical characteristics of an application.

**B. Visual Inspection**

Inspect head assembly for worn, cracked, or broken jaws. If damage is evident, return the crimping head to Tyco Electronics for evaluation and repair. See Section 7, REPLACEMENT AND REPAIR.

**C. Crimping Die Closure Inspections**

Each crimping head is inspected for proper die closure before shipment. However, inspection of die closure for excessive wear is required periodically.

This inspection requires the use of plug gages conforming to the dimension shown in Figure 5. Tyco Electronics does not manufacture or market these gages.

To gage die closure, refer to Figure 6 and proceed as follows:

1. Remove traces of oil or dirt from the crimping chamber and plug gage.

2. Close the tool until the wire barrel dies are bottomed.

3. With wire barrel dies bottomed, inspect the wire barrel crimp die closure using the proper plug gage. Press the spring-loaded locator down and hold gage in alignment with the die closure.

4. Align the GO element with the wire barrel section of the crimping chamber. Push element straight into the crimping chamber without using force. The GO element must pass completely through the crimping chamber. See Figure 6.

5. Align the NO-GO element and try to insert it straight into the same section of the crimping chamber. The NO-GO element may start entry, but must not pass completely through the crimping chamber. See Figure 6.

6. Insert tool insulation crimping adjustment pin into Position 1.

7. With crimping dies bottomed, check the insulation barrel section of the crimping chamber as described in Steps 4 and 5.

If the crimping chamber conforms to the gage inspection, the crimping head is considered dimensionally correct, and should be lubricated with a THIN coat of any good SAE 20 motor oil. If not, the crimping head must be returned to Tyco Electronics for further evaluation and repair. Refer to Section 7, REPLACEMENT AND REPAIR.

For additional information regarding the use of plug gages, refer to Instruction Sheet 408-7424.

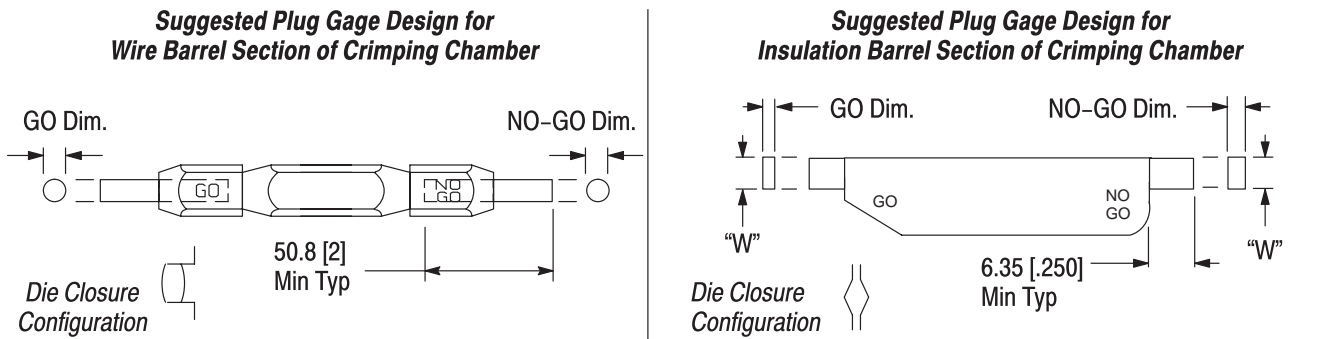

HEAD PART NUMBER	WIRE BARREL CRIMP CHAMBER		INSULATION BARREL CRIMP CHAMBER		
	GO	NO-GO	GO	NO-GO	WIDTH (W)
1-576778-0	2.591-2.598 [.1020-.1023]	2.690-2.692 [.1059-.1060]	0.813-0.820 [.0320-.0323]	1.217-1.219 [.0479-.0480]	4.06 [.160]
1-576779-0	2.591-2.598 [.1020-.1023]	2.690-2.692 [.1059-.1060]	1.067-1.074 [.0420-.0423]	1.471-1.473 [.0579-.0580]	4.39 [.173]
1-576780-0	3.048-3.056 [.1200-.1203]	3.147-3.150 [.1239-.1240]	0.940-0.947 [.0370-.0373]	1.344-1.346 [.0529-.0530]	5.89 [.232]
1-576781-0	3.124-3.132 [.1230-.1233]	3.223-3.226 [.1269-.1270]	0.940-0.947 [.0370-.0373]	1.344-1.346 [.0529-.0530]	5.89 [.232]
1-576782-0	3.327-3.335 [.1310-.1313]	3.426-3.429 [.1349-.1350]	1.067-1.074 [.0420-.0423]	1.471-1.473 [.0579-.0580]	6.63 [.261]

Figure 5

**(Detail A) Inspection of Wire Barrel Crimping Dies**

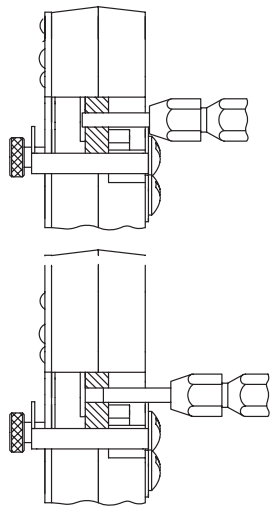
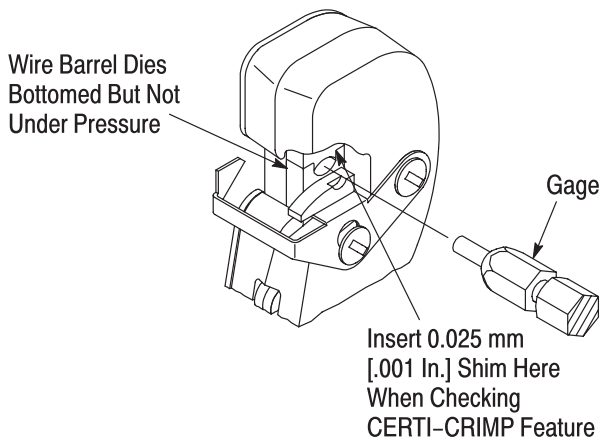

GO gage must pass completely through the die closure.

NO-GO gage may enter partially, but must not pass completely through the die closure.

**(Detail B) Inspection of Insulation Crimping Dies**

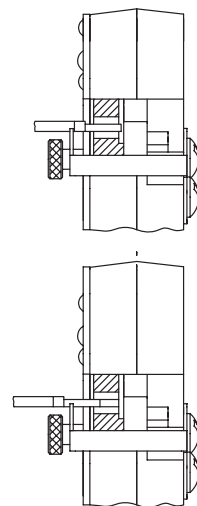
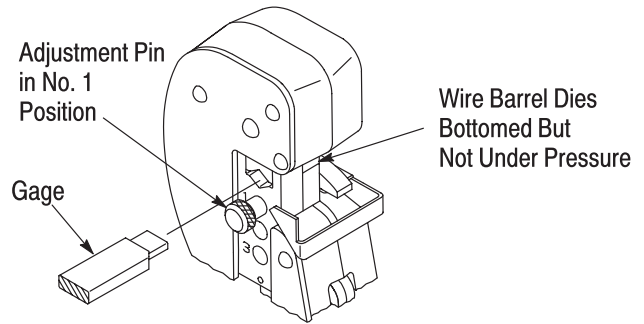

Figure 6

**8. REPLACEMENT AND REPAIR**

Replaceable parts are listed in Figure 7. Parts other than those listed in Figure 7 should be replaced by Tyco Electronics to ensure quality and reliability of the tool. Order replacement parts through your Tyco Electronics Representative, or call 1-800-526-5142, or send a facsimile of your purchase order to 1-717-986-7605, or write to:

CUSTOMER SERVICE (38-35)  
 TYCO ELECTRONICS CORPORATION  
 P.O. BOX 3608  
 HARRISBURG, PA 17105-3608

For tool repair service, please contact an Tyco Electronics Representative at 1-800-526-5136.

**9. REVISION SUMMARY**

- Updated document to corporate requirements
- Deleted text and changed wire size from 24-10 to 24-14 in Section 1, INTRODUCTION
- Deleted 12-10 wire information in tables in Figures 2, 5, and 7
- Changed part numbers in table in Figure 7

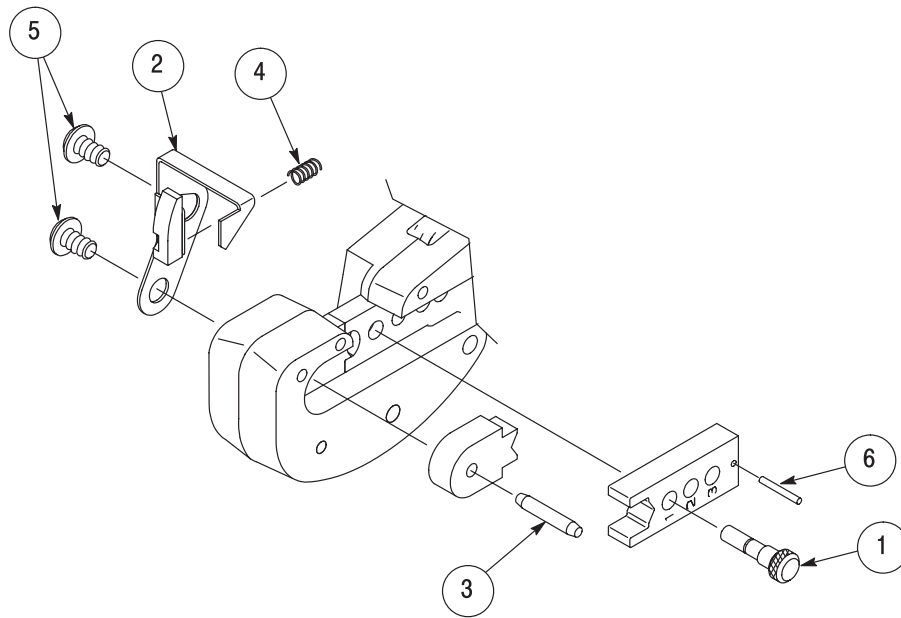

ITEM NO.	DESCRIPTION	QTY PER HEAD	PIDG STRATO-THERM TERMINAL CRIMPING HEAD REPLACEMENT PARTS				
			1-576778-0	1-576779-0	1-576780-0	1-576781-0	1-576782-0
1	PIN, Adjustment	1	1752891-1	1752891-1	1752891-1	1752891-1	1752891-1
2	LOCATOR, Stop	1	59580-6 1901238-1	59580-6 1901238-1	59580-6 1901238-2	59580-6 1901238-2	59580-6 1901238-2
3	PIN	1	5-21028-7	5-21028-7	5-21028-7	5-21028-7	5-21028-7
4	SPRING	1	7-59683-6	7-59683-6	7-59683-6	7-59683-6	7-59683-6
5	SCREW	2	6-306131-4	6-306131-4	6-306131-4	6-306131-4	6-306131-4
6	PIN	1	21028-4	21028-4	21028-4	21028-4	21028-4

Figure 7