

Figure 1

1. INTRODUCTION

Crimping Heads 1-46673-0, 1-46673-1, and 1-46988-0 are designed to crimp STRATO-THERM Terminals and Splices onto wire size 26-14 AWG. Refer to Figure 2. The crimping heads are used with Double Action Battery Powered Hand Tool Kits 1213804-[].

NOTE

The crimping heads can also be used with the 626 Double Action Pneumatic Tool Adapter 1213563-1.

This instruction sheet provides recommended procedures for wire preparation, crimping head installation, crimping, and maintenance and

inspection. For information concerning tool setup and operation, refer to Customer Manual 409-10056 packaged with the battery tool kit.

NOTE

Dimensions are in metric units with [inches in brackets]. Figures and illustrations are for reference only and are not drawn to scale.

Reasons for reissue are provided in Section 8, REVISION SUMMARY.

2. DESCRIPTION

The crimping head consists of integral jaws which close in an arc-like motion. After an operator locates the terminal or splice between the crimping jaws and

inserts the stripped wire, the tool is activated to crimp the terminal or splice to the wire.

TOOL	WIRE	
	SIZE (AWG)	STRIP LENGTH
1-46673-0	22-16	5.16-5.94 [.203-.234]
1-46673-1●		
1-46988-0	16-14	

NOTE: ●For wires with thin-wall insulation.
Figure 2

3. HEAD INSTALLATION AND REMOVAL

3.1. Head Selection

NOTE Crimping heads are coated with a preservative to prevent rust and corrosion. Wipe this preservative from the head, particularly from the crimping surfaces.

3.2. Installation

DANGER To avoid personal injury, be sure to exercise extreme caution when handling the crimp tool. Avoid accidentally depressing the trigger control when installing or removing crimp heads.

DANGER DO NOT operate the battery tool without the proper crimping head installed. After crimping head is installed, make sure that the quick pins are properly inserted to avoid personal injury and damage to the tool.

1. Remove quick pins from the adapter assembly. Refer to Figure 1.
2. Insert crimping head into the adapter assembly.
3. After the crimping head is properly aligned, insert the quick pins through the two holes in the adapter and through the holes in the crimp head.

NOTE The quick pins will “snap” into position when they are properly inserted.

3.3. Removal

DANGER To avoid personal injury, ALWAYS disconnect the battery from the tool before removing crimping head.

Remove the quick pins from the crimping head; then remove the crimping head from the tool holder.

4. CRIMPING PROCEDURES

DANGER To avoid personal injury, ALWAYS keep fingers clear of crimping jaws when operating the tool. Never place anything within the crimping jaws except Tyco Electronics terminals or splices.

4.1. Crimping Procedure

1. Strip wire to dimensions shown in Figure 2. DO NOT nick wire strand or use wires with nicked or missing conductor strands.
2. Push the locator up and, from the FRONT side of the tool, insert the terminal or splice wire barrel sleeve into the crimping jaws making sure that the edge of the wire barrel sleeve rests against the locator. See Figures 3 and 4.
3. Depress the trigger to advance the moving ram. This closes the crimp jaws in order to hold the terminal in place. DO NOT deform the wire barrel.
4. Insert wire conductor through the insulation barrel sleeve and into the wire barrel sleeve until it is flush with the outer edge of the wire barrel sleeve.

NOTE The wire barrel sleeve on high-temperature terminals and splices is color-coded orange. Heat-resistant terminals and splices are not color-coded. Refer to Figure 5.

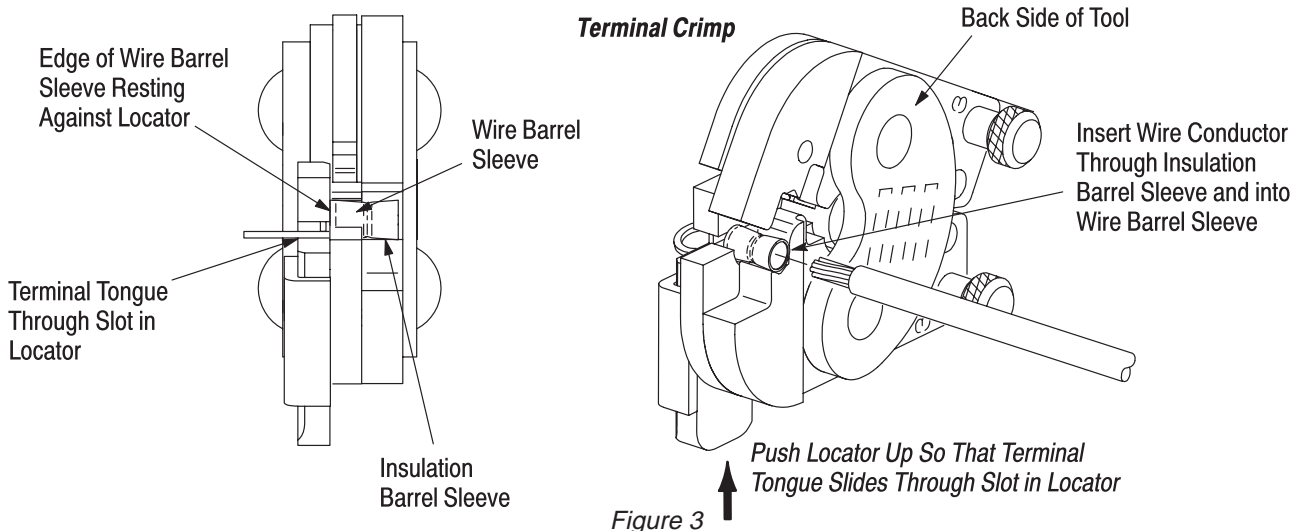

Figure 3

Splice Crimp (First Crimp)

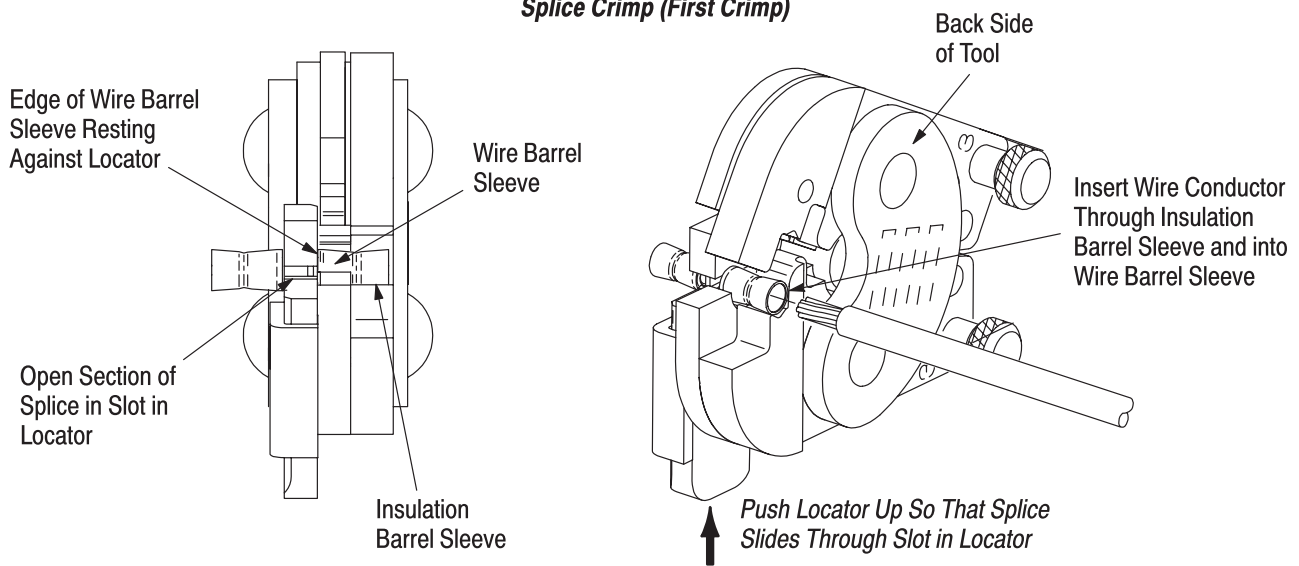

Figure 4

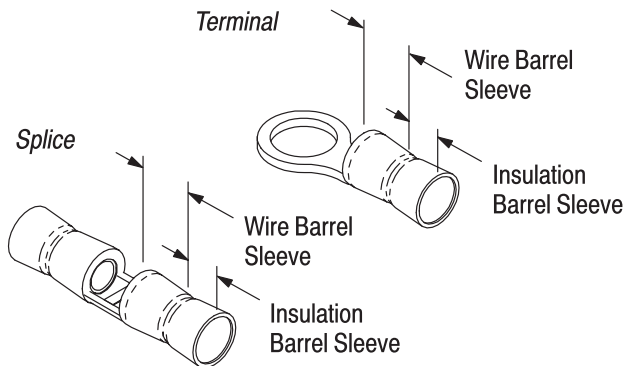

Figure 5

NOTE Always place both adjustment pins in the same position. See Figure 6.

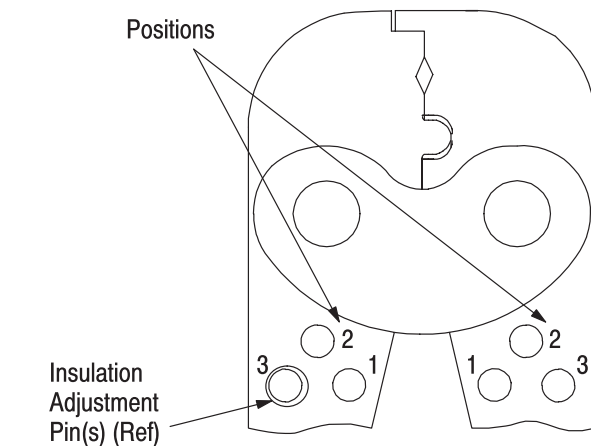

Figure 6

5. Activate the tool to complete the crimp. The crimp tool automatically returns to the first position of the cycle when the crimp is complete.

6. Allow tool head to open FULLY. Remove the crimped terminal or splice from the crimping jaws.

7. To crimp the other half of the splice, reposition the uncrimped sleeve in the crimping jaws as described in Step 2. Follow Steps 3 through 6 to complete the crimp.

8. Refer to Section 5 and Figure 7 for crimp inspection.

4.2. Insulation Crimp Adjustment

The insulation crimping section of the crimping head has three positions: 1—Tight; 2—Medium; and 3—Loose.

1. Insert insulation adjustment pins in Position 3. See Figure 6.

2. Place terminal or splice in crimping jaws, as shown in Figures 3 and 4.

3. Insert **unstripped wire only into the insulation barrel** of the terminal or splice. See Figures 3 and 4.

4. Crimp terminal or splice as described in Paragraph 4.1.

5. Remove terminal or splice. Bend wire forward and then backward. The terminal or splice should retain its grip on the wire. If the wire pulls out, reposition the insulation adjustment pins in the next tighter position and repeat crimping procedure.

6. Repeat adjustment as necessary until desired insulation grip is obtained. **DO NOT** use a tighter setting than required.

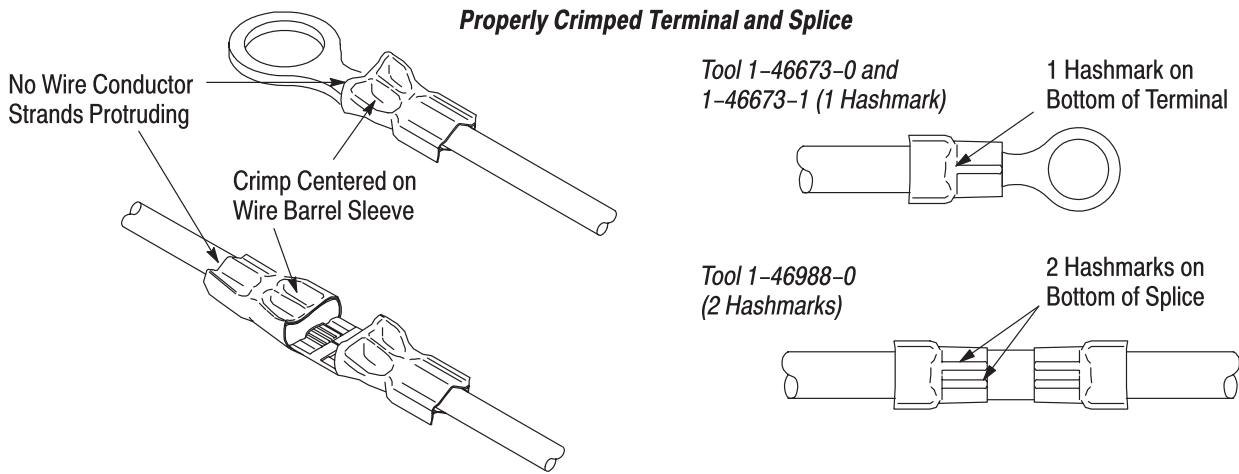

Figure 7

5. CRIMP INSPECTION

Inspect crimped terminals and splices by checking the features described in Figure 7. Use only terminals or splices that meet the conditions shown in the “ACCEPT” column. “REJECT” terminations can be avoided through careful use of instructions in Section 4, and by performing regular head maintenance, as described in Section 6.

CAUTION

Damaged product should not be used. If a damaged terminal or splice is evident, it should be cut from the wire and replaced. Do NOT re-terminate terminals or splices.

6. MAINTENANCE AND INSPECTION

DANGER

To avoid personal injury, ALWAYS disconnect the battery from the tool before performing maintenance or inspection.

Tyco Electronics recommends that a maintenance and inspection program be performed periodically to ensure dependable and uniform terminations. The crimping head should be inspected once a month. Frequency of inspection should be adjusted to suit your requirements through experience. Frequency of inspection depends on:

1. The care, amount of use, and handling of the crimping head.
2. The type and size of the product crimped.
3. The degree of operator skill.
4. The presence of abnormal amounts of dust and dirt.
5. Your own established standards.

Each crimping head is thoroughly inspected before packaging. Since there is the possibility of crimping head damage during shipment, new crimping heads

should be inspected immediately upon arrival at your facility.

6.1. Daily Maintenance

Tyco Electronics recommends that each operator be responsible for the following steps of daily maintenance:

1. Remove dust, moisture, and other contaminants with a clean, soft brush, or a lint-free cloth. Do NOT use objects that could damage the head.
2. Make sure that all pins, rings, and other components are in place and secure.

DANGER

To avoid personal injury and damage to the tool, make sure quick pins are properly inserted.

3. Make certain all surfaces are protected with a thin coat of any good SAE 20 motor oil. Do NOT oil excessively.
4. When the head assembly is not in use, store it in a clean dry, area.

6.2. Periodic Inspection

Regular inspections should be performed by quality control personnel. A record of scheduled inspections should remain with the crimping heads or be supplied to supervisory personnel responsible for the crimping heads. Though recommendations call for at least one inspection a month, the frequency should be based on amount of use, working conditions, operator training and skill, and your established company policies. These inspections should include a visual inspection (Paragraph 6.3) and a crimping chamber inspection (Paragraph 6.5).

6.3. Visual Inspection

1. Remove all lubrication and accumulated film by immersing the crimping head in a suitable commercial degreaser that will not affect paint or plastic.

2. Make certain all components are in place. If replacements are necessary, refer to Figure 10.
3. Check all bearing surfaces for wear. Replace worn parts.
4. Inspect crimp area for flattened, chipped, or broken areas. Replace worn or damaged parts.

6.4. Lubrication

Lubricate all pins, pivot points, and bearing surfaces with a high quality grease. Tyco Electronics recommends the use of Molykote grease, which is a commercially available lubricant. Lubricate according to the following schedule:

- Head used in daily production – lubricate daily
- Head used daily (occasional) – lubricate weekly
- Head used weekly – lubricate monthly

Wipe excess grease from crimping head, particularly from jaw closure areas. Grease transferred from jaw closure area onto certain terminations may affect the electrical characteristics of an application.

6.5. Gaging the Crimping Chamber

This inspection requires the use of plug gages conforming to the dimensions shown in Figure 8. Tyco Electronics does not manufacture or market these gages.

Suggested Plug Gage Design for Insulation Barrel Section of Crimping Chamber

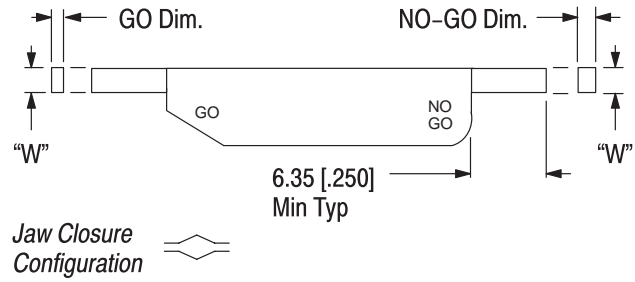

HAND TOOL	GAGE ELEMENT DIMENSIONS		
	GO	NO-GO	"W" (Width) (Max)
1-46673-0 1-46673-1	0.762-0.770 [.0300-.0303]	1.267-1.270 [.0499-.0500]	3.05 [.120]
1-46988-0	1.016-1.024 [.0400-.0403]	1.521-1.524 [.0599-.0600]	

Figure 8 (end)

DANGER

Disconnect the battery and remove crimping head from tool before inspecting crimping chambers.

1. Remove oil and dirt from the jaw bottoming surfaces and plug gage element surfaces.
2. Close wire barrel crimping jaws until they are bottomed, but not under pressure.
3. Align GO element with wire barrel crimping section. Push element straight into crimping chamber without using force. The GO element must pass completely through the chamber as shown in Figure 9.
4. Align the NO-GO element and try to insert it into the chamber. The element may start entry, but it must not pass completely through the crimping chamber.
5. Repeat this procedure for the insulation crimping section using a plug gage as shown in Figure 8.

If the crimping chamber passes the gage inspection, the crimping head is considered dimensionally correct and should be lubricated with a THIN coat of any good SAE 20 motor oil. If the crimping chamber does not conform to the plug gage conditions, contact your local Tyco Electronics Field Representative or refer to Section 7, REPLACEMENT AND REPAIR.

For additional information about the use of a plug gage, see Instruction Sheet 408-7424.

Suggested Plug Gage Design for Wire Barrel Section of Crimping Chamber

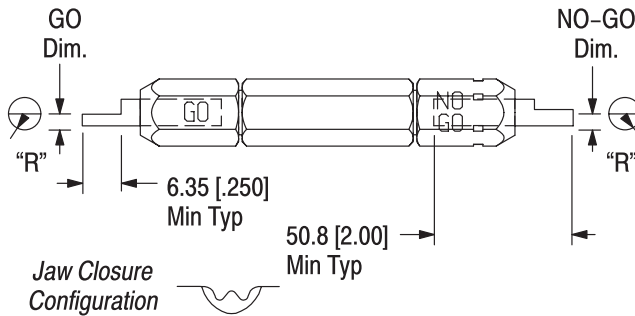

HAND TOOL	GAGE ELEMENT DIMENSIONS		
	GO	NO-GO	"R" (Radius)
1-46673-0 1-46673-1	1.499-1.506 [.0590-.0593]	1.648-1.651 [.0649-.0650]	1.57 [.062]
1-46988-0	1.702-1.709 [.0670-.0673]	1.851-1.854 [.0729-.0730]	

Figure 8 (cont'd)

Inspection of Wire Barrel Section of Crimping Chamber

Inspection of Insulation Barrel Section of Crimping Chamber

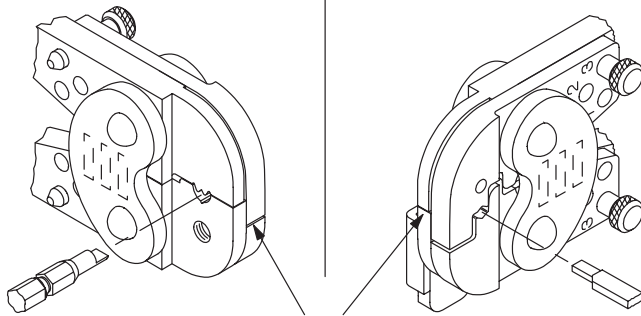

Jaws Bottomed But Not Under Pressure

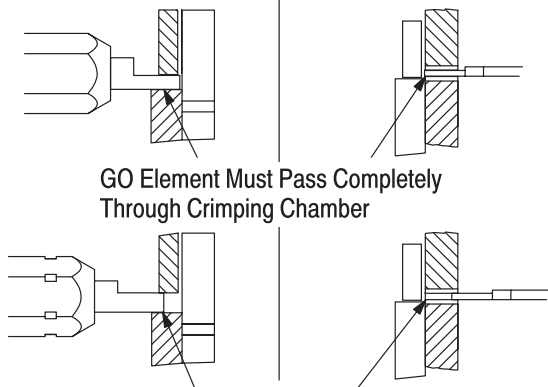

GO Element Must Pass Completely Through Crimping Chamber

NO-GO Element May Start Entry, But Must Not Pass Completely Through Crimping Chamber

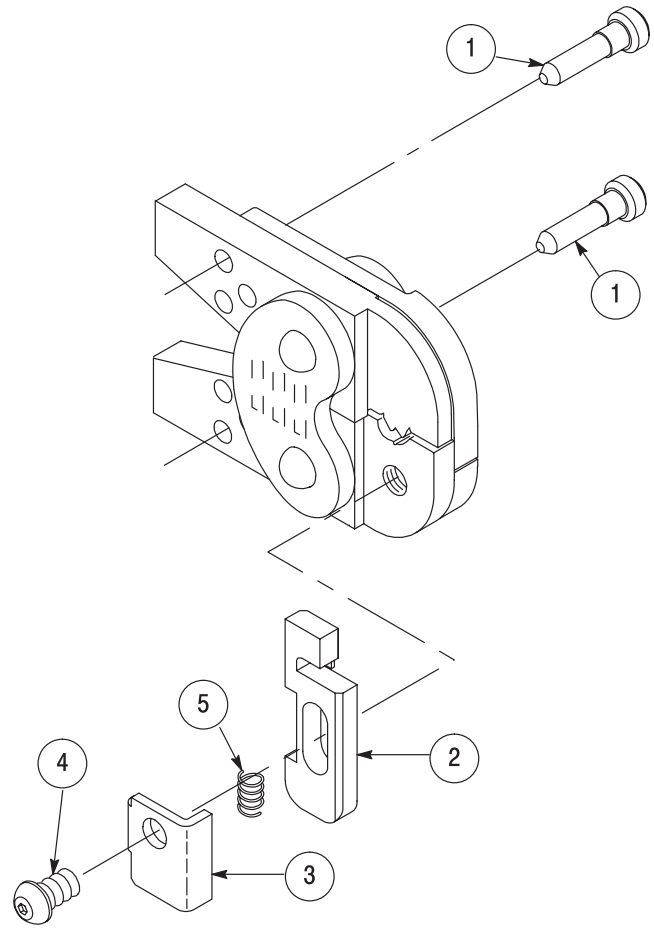

Figure 9

7. REPLACEMENT AND REPAIR

Replacement parts and recommended spares are listed in Figure 10. The recommended spares should be stocked for immediate replacement.

Order replacement parts through your Tyco Electronics Representative, or call 1-800-526-5142, or send a facsimile of your purchase order to 1-717-986-7605, or write to:

CUSTOMER SERVICE (38-35)
TYCO ELECTRONICS CORPORATION
P.O. BOX 3608
HARRISBURG, PA 17105-3608

For further repair and replacement information, call the Tyco Electronics Tooling Assistance Center at the number at the bottom of page 1.

REPLACEMENT PARTS

ITEM NO.	PART NUMBER	DESCRIPTION	QTY PER HEAD
1	39207	PIN, Insulation Crimping Adjustment	2
2	305363	LOCATOR	1
3	302994	HOUSING, Locator	1
4	9-305927-1	SCREW	1
5	301201	SPRING	1

Figure 10

8. REVISION SUMMARY

- Initial release of document