

**PROPER USE GUIDELINES**

Cumulative Trauma Disorders can result from the prolonged use of manually powered hand tools. AMP hand tools are intended for occasional use and low volume applications. AMP offers a wide selection of powered application equipment for extended-use, production operations.

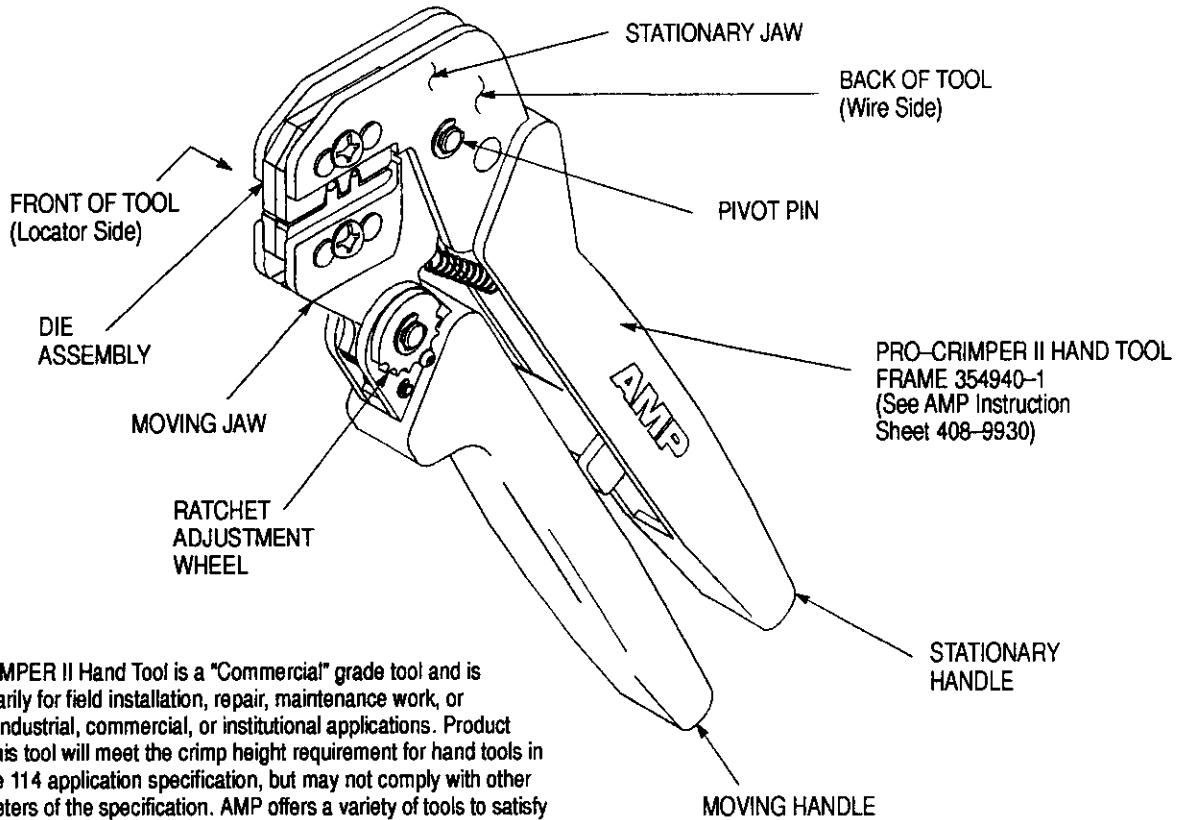

The PRO-CRIMPER II Hand Tool is a "Commercial" grade tool and is designed primarily for field installation, repair, maintenance work, or prototyping in industrial, commercial, or institutional applications. Product crimped with this tool will meet the crimp height requirement for hand tools in the appropriate 114 application specification, but may not comply with other feature parameters of the specification. AMP offers a variety of tools to satisfy your performance requirements. For additional information, contact the Technical Assistance Center at 1-800-722-1111.

DIE ASSEMBLY PART NUMBER	LOCATOR ASSY PART NUMBER†	CONTACT FAMILY‡	WIRE		
			SIZE (AWG)	INSUL DIA (mm [in.])	STRIP LENGTH (mm [in.])
58541-2	189382-1	67 MULTIMATE* Type II Contacts	24 to 20	1.40 to 2.16 [.055 to .085]	5.31 [.209]
			18 to 14	OPEN	6.35 [.250]

† Supplied with die assembly, also available separately.

‡ Contact the AMP Technical Assistance Center (see below) for specific contact part numbers.

Figure 1

**1. INTRODUCTION**

AMP PRO-CRIMPER II Hand Tool Assembly 58541-1 consists of Die Assembly 58541-2 and AMP PRO-CRIMPER II Hand Tool Frame 354940-1. The die assembly consists of crimping dies and a locator assembly. Read these instructions thoroughly before crimping any contacts.

**NOTE**

Dimensions on this sheet are in millimeters [with inch equivalents provided in brackets]. Figures and illustrations are for identification only and are not drawn to scale.

Reasons for reissue are provided in Section 10, REVISION SUMMARY.

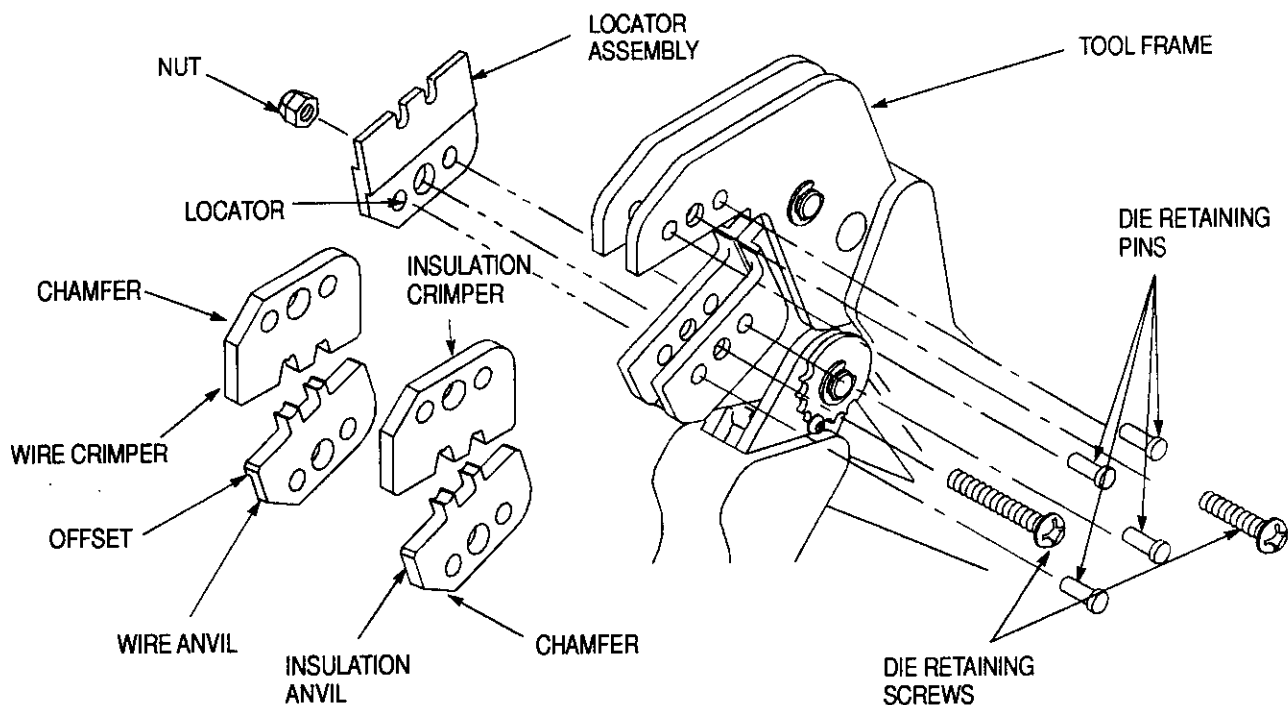

Figure 2

## 2. DESCRIPTION (Figures 1 and 2)

The tool features a tool frame with a stationary jaw and handle, a moving jaw, a moving handle, and an adjustable ratchet that ensures full contact crimping. The tool frame holds a die assembly with two crimping sections.

The die assembly features a wire anvil, an insulation anvil, a wire crimper, and an insulation crimper. Attached to the outside of the frame is a locator assembly.

Die retaining pins and die retaining screws are used to position and secure the dies in the tool frame. A nut is used on the lower die retaining screw to hold the locator assembly in place.

## 3. INSTALLATION AND REMOVAL OF DIE SET AND LOCATOR ASSEMBLY (Figure 2)

1. Open the tool handles and remove the two die retaining screws from the tool jaws.
2. Place the wire anvil and insulation anvil so that their chamfered sides and their marked surfaces face outward, when mounted in the moving jaw of the tool frame.
3. Insert the two die retaining pins.
4. Insert the long die retaining screw through the jaw and through both anvil dies, and tighten the screw just enough to hold the dies in place. Do *not* tighten the screw completely at this time.
5. Place the wire crimper and insulation crimper so that their chamfered sides and their marked surfaces face outward, when mounted in the stationary jaw of the tool frame.
6. Insert the two die retaining pins.
7. Insert the short die retaining screw through the jaw and through both crimper dies, and tighten the screw just enough to hold the dies in place. Do *not* tighten the screw completely at this time.
8. Carefully close the tool handles, making sure that the anvils and crimpers align properly. Continue closing the tool handles until the ratchet in the tool frame has engaged sufficiently to hold the anvils and crimpers in place, then tighten both die retaining screws.
9. Place the locator assembly over the end of the long screw, and position the locator assembly against the side of the tool jaw.
10. Place the nut onto the end of the long screw and tighten the nut enough to hold the locator assembly in place.
11. To disassemble, close the tool handles until the ratchet releases, remove the nut, the locator assembly, the two die retaining screws, and the four die retaining pins, and slide the anvils and crimpers out of the tool jaws.

#### 4. CRIMPING PROCEDURE

##### NOTE

This tool is provided with a crimp adjustment feature. Initially, the crimp height should be verified as specified in Figure 4. Refer to Section 5, CRIMP HEIGHT INSPECTION, and Section 6, CRIMP HEIGHT ADJUSTMENT, to verify crimp height before using the tool to crimp desired contacts and wire sizes.

Refer to the table in Figure 1 and select wire of the specified size and insulation diameter. Strip the wire to the length indicated in Figure 1, taking care not to nick or cut wire strands. Select an applicable contact and identify the appropriate crimp section according to the wire size markings on the tool. Refer to Figure 3 and proceed as follows:

1. Hold the tool so that the back (wire side) is facing you. Squeeze tool handles together and allow them to open fully.
2. Holding the contact by the mating end, insert the contact — insulation barrel first — through the front of the tool and into the appropriate crimp section.
3. Position the contact so that the mating end of the contact is on the locator side of the tool. Refer to Figure 3. Butt the contact shoulder against the locator.

##### CAUTION

Do NOT attempt to crimp an improperly positioned contact.

4. Hold the contact in position and squeeze the tool handles together until ratchet engages

sufficiently to hold the contact in position. Do NOT deform insulation barrel or wire barrel.

5. Fully insert the stripped wire into the contact as shown in Figure 3.
6. While holding the wire in place, squeeze the tool handles together until ratchet releases. Allow the tool handles to open, and remove the crimped contact.
7. Check the contact's crimp height as described in Section 5, CRIMP HEIGHT INSPECTION. If necessary, adjust the crimp height as described in Section 6, CRIMP HEIGHT ADJUSTMENT.

#### 5. CRIMP HEIGHT INSPECTION

This inspection requires the use of a micrometer with a modified anvil. AMP recommends the modified micrometer (Crimp Height Comparator RS-1019-5LP) which may be purchased from:

Shearer Industrial Supply Co.  
20 North Penn Street  
York, PA 17401-1014

or VALCO  
1410 Stonewood Drive  
Bethlehem, PA 18017-3527

Proceed as follows:

1. Refer to Figure 4 and select a wire (maximum size) for each crimp section listed.
2. Refer to Section 4, CRIMPING PROCEDURE, and crimp the contact(s) accordingly.

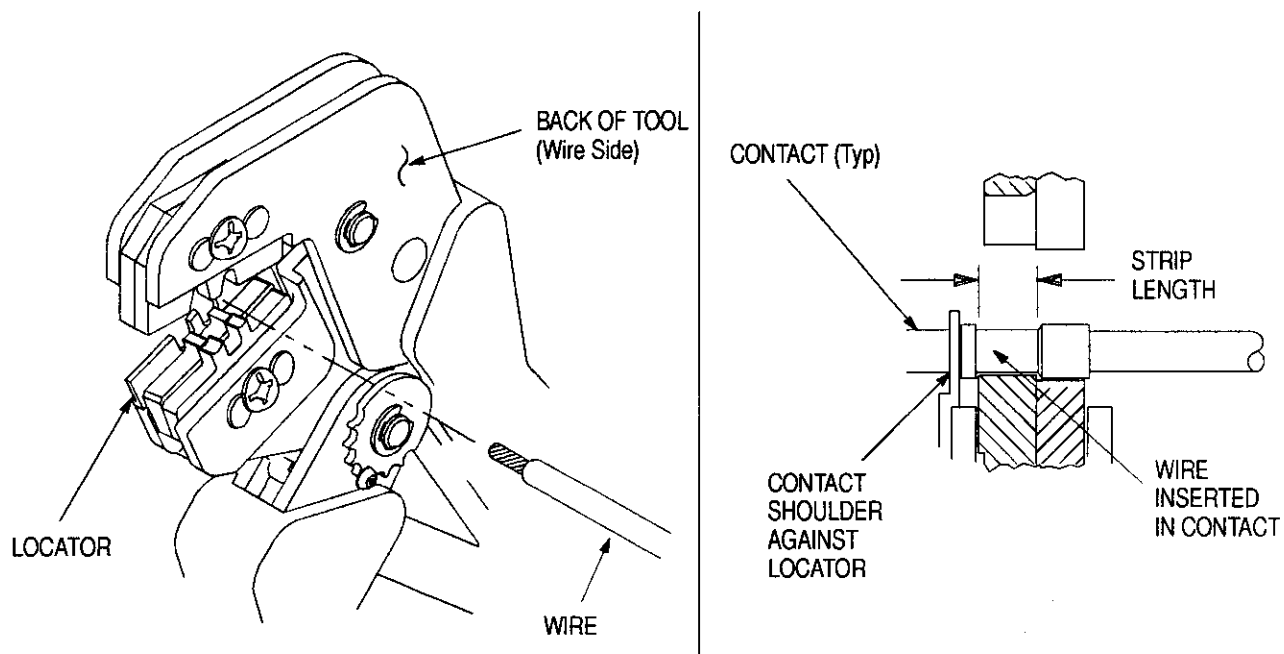
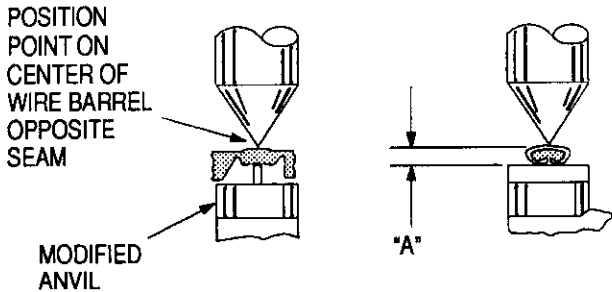

Figure 3

3. Using a crimp height comparator, measure the wire barrel crimp height as shown in Figure 4. If the crimp height conforms to that shown in the table, the tool is considered dimensionally correct. If not, the tool must be adjusted. Refer to Section 6, **CRIMP HEIGHT ADJUSTMENT**.



WIRE SIZE AWG (MAX)	CRIMP SECTION (WIRE SIZE MARKING)	CRIMP HEIGHT DIM. (A) AND TOLERANCE (±)
20	20-24	1.09 ± .051 [.043 ± .002]
14	18-16-14	1.60 ± .051 [.063 ± .002]

Figure 4

**6. CRIMP HEIGHT ADJUSTMENT** (Figure 5)

1. Remove the lock screw from the ratchet adjustment wheel.
2. With a screwdriver, adjust the ratchet wheel from the locator side of the tool.
3. Observe the ratchet adjustment wheel. If a tighter crimp is required, rotate the adjustment wheel **COUNTERCLOCKWISE** to a higher-numbered setting. If a looser crimp is required, rotate the adjustment wheel **CLOCKWISE** to a lower-numbered setting.

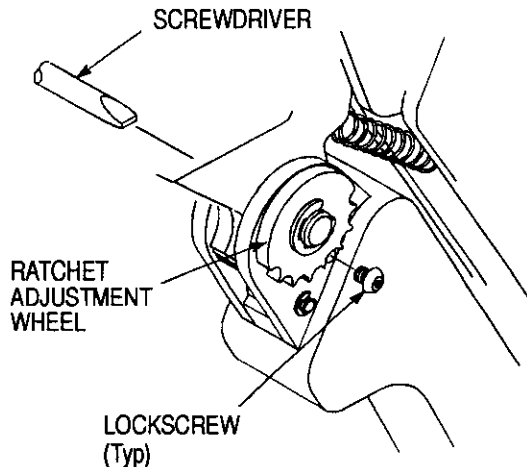

Figure 5

4. Replace the lock screw.
5. Make a sample crimp and measure the crimp height. If the dimension is acceptable, replace and secure the lock screw. If the dimension is unacceptable, continue to adjust the ratchet, and again measure a sample crimp.

**7. MAINTENANCE**

Ensure that the tool and dies are clean by wiping them with a clean, soft cloth. Remove any debris with a clean, soft brush. Do not use objects that could damage the tool. When not in use, keep handles closed to prevent objects from becoming lodged in the crimping dies, and store in a clean, dry area.

**8. VISUAL INSPECTION**

The crimping dies should be inspected on a regular basis to ensure that they have not become worn or damaged. Inspect the crimp sections for flattened, chipped, worn, or broken areas. If damage or abnormal wear is evident, the tool must be replaced. See Section 9, **REPLACEMENT**.

**9. REPLACEMENT**

Customer-replaceable parts are shown in Figure 1. Available separately, AMP PRO-CRIMPER II Repair Kit 679221-1 includes a replacement nut and a variety of pins, rings, screws, and springs. If the dies are damaged or worn excessively, they must be replaced. Order the repair kit and replaceable parts through your AMP representative, or call 1-800-526-5142, or send a facsimile of your purchase order to 1-717-986-7605, or write to:

CUSTOMER SERVICE (38-35)  
AMP INCORPORATED  
P.O. BOX 3608  
HARRISBURG, PA 17105-3608

**10. REVISION SUMMARY**

Since the previous release of this sheet, the following changes were made:

Per EC 0150-3338-95

- Added note in Figure 1.
- Deleted note in Section 1, **INTRODUCTION**.
- Changed Crimp Height Comparator RH-1019-LAP to RS-1019-5LP.
- Changed York Machinery & Supply Co. to Shearer Industrial Supply Co.

Per EC 0990-0252-93

- Added "REVISION SUMMARY."