

LOC	DIST	REVISIONS					
		P	LTR	DESCRIPTION	DATE	DWN	APVD
A1	-		A	new drawing	11FEB2002	-	-

Kontakt Contact	DGB (mm ²) Wire Range	Drahtcrimp/Wirecrimp		Isocrimp	Ins.-Ø	Betriebsanl. Instr. Sheet
		Hoehe/Height	Breite/Width	Breite/Width	Ins. Range	
967713 / 967719 / 968872	0.5	1.18	2.03	2.54	1.4-1.6	411-18167
	0.75	1.27			1.7-1.9	
	1.0	1.36			1.9-2.1	

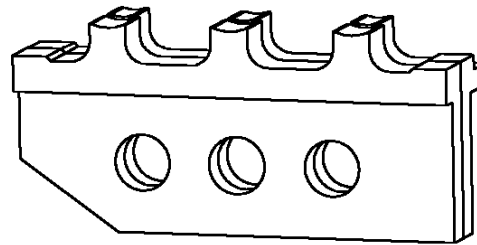
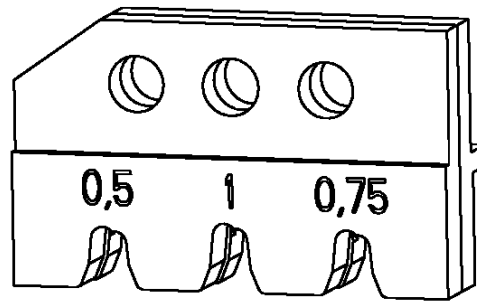

539722-2	1	1-539787-4	locator ass.	Positioniereinheit	A
	1	1-539786-3	contact guide	Kontaktabstuetzung	A
	1	1-519151-3	screw M4x25	Schraube M4x25	A
	1	1-519151-2	screw M4x20	Schraube M4x20	A
	1	0-519024-2	hex nut M4	Mutter M4 DIN 985	A
	1	0-519021-8	hex nut M4	Mutter M4 DIN 934	A
	QTY Stck	PN	Description	Benennung	REV

RELEASED FOR PUBLICATION 19

THIS DRAWING IS UNPUBLISHED.

BY TYCO ELECTRONICS CORPORATION. ALL RIGHTS RESERVED.
COPYRIGHT 19

DIMENSIONS: mm-DIN 7168-m		DWN M.Weberdoerfer	18NOV99	MATERIAL -	FINISH -		
TOLERANCES UNLESS OTHERWISE SPECIFIED: 0 PLC ± 1 PLC ± 2 PLC ± 3 PLC ± 4 PLC ± ANGLES ±		CHK U.Reuter	18NOV99	AMP tyco Electronics AMP GmbH D - 64625 Bensheim			
		APVD -	-				
		PRODUCT SPEC -	NAME ERGOCRIMP Die Set for MCP 2.8 mm and 2.8 mm Sensor-Flattype Rec.				
		APPLICATION SPEC -	SIZE A 4	CAGE CODE 00779	DRAWING NO C=539722-2	RESTRICTED TO -	
WEIGHT -		CUSTOMER DRAWING			SCALE 2:1	SHEET 1 OF 1	REV A