

4

3

2

1

THIS DRAWING IS UNPUBLISHED. RELEASED FOR PUBLICATION 2005
 © COPYRIGHT 2005 BY TYCO ELECTRONICS CORPORATION. ALL RIGHTS RESERVED.

LOC	DIST	REVISIONS				
P	LTR	DESCRIPTION	DATE	DWN	APVD	
B		ECR-05-11332	07SEP2005	-	-	

Matrize in Kombination mit Ergocrimp Basishandzange PN 539635-1 verwenden
 Use die in combination with Ergocrimp basis hand tool PN 539635-1

Matrize im Karton mit Bedienungsanleitung 411-18266 verpackt
 Die packed in a cardboard with instruction sheet 411-18266

0-1579001-5	1	3-0744010-7	Instruction Sheet	Bedienungsanleitung	6
	1	0-0519024-2	Nut M4 DIN 985	Mutter M4 DIN 985	5
	1	1-0519151-3	Screw M4x25	Schraube M4x25	4
	1	1-0519151-1	Screw M4x16	Schraube M4x16	3
	1	4-1579005-3	Locator Assembly	Drahtanschlag	2
	1	1-1579005-8	Contact Locator	Kontaktpositionierer	1
QTY		PN	Description	Benennung	Pos.

Kontakt	AWG (mm ²)	Drahtcrimp / Wire Crimp		Isolationscrimp/Insulationcrimp		Isol.Ø	Betriebsant.
Contact	Wire Range	Höhe/Height mm	Breite/Width mm	Höhe/Height mm	Breite/Width mm	Ins.Range	Instr.Sheet
1534063	AWG20/0.50	0.98 ±0.03	1.57 F	2.05 max.	1.83 0	1.4-1.6	411-18266
	0.75	1.09 ±0.03		2.05 max.		1.7-1.9	
	-----	-----		-----		-----	

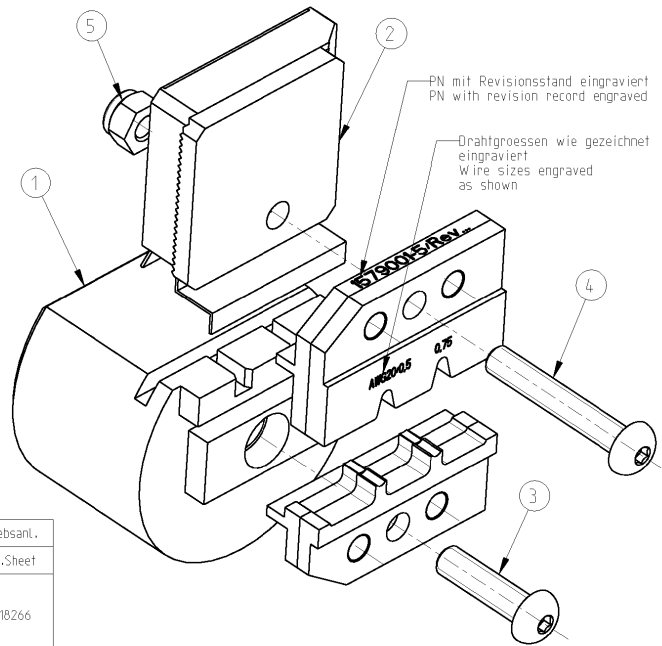

<small>THIS DRAWING IS A CONTROLLED DOCUMENT FOR TYCO ELECTRONICS CORPORATION IT IS SUBJECT TO CHANGE AND THE CONTROLLING ENGINEERING ORGANIZATION SHOULD BE CONTACTED FOR THE LATEST REVISION.</small>		DWN Ch.Witt	07SEP2005	tyco Electronics tyco Electronics AMP GmbH D - 64625 Bensheim
DIMENSIONS: mm 		CHK -	-	
TOLERANCES UNLESS OTHERWISE SPECIFIED: 0 PLC ±0.1 1 PLC ±0.1 2 PLC ±0.1 3 PLC ±0.1 4 PLC ±0.1 ANGLES ±1°		APVD -	-	NAME ERGOCRIMP DIE SET MCP 1.2 CLEAN BODY Ergocrimp Matrize MCP 1.2 Clean Body
MATERIAL - FINISH -		PRODUCT SPEC -	-	APPLICATION SPEC -
		SIZE A3	CAGE CODE 00779	DRAWING NO. G-1579001-5
		WEIGHT -	RESTRICTED TO -	
		CUSTOMER DRAWING		SCALE 2:1 SHEET 1 OF 1 REV B

AMP 1470-19 REV 31MAR2000

Pro/ENGINEER DRAWING