

4

3

2

1

THIS DRAWING IS UNPUBLISHED. RELEASED FOR PUBLICATION 2003  
 © COPYRIGHT 2003 BY TYCO ELECTRONICS CORPORATION. ALL RIGHTS RESERVED.

LOC	DIST	REVISIONS				
P	LTR	DESCRIPTION	DATE	DWN	APVD	
B		EGC0-0075-04	05MAY2004	witt	-	
C		EGC0-0296-04	18NOV2004	witt	-	

Matrize in Kombination mit Ergocrimp Basishandzange PN 539635-1 verwenden  
 Use die in combination with Ergocrimp basis hand foot PN 539635-1

Matrize im Karton mit Bedienungsanleitung 411-18260 verpackt  
 Die packed in a cardboard with instruction sheet 411-18260

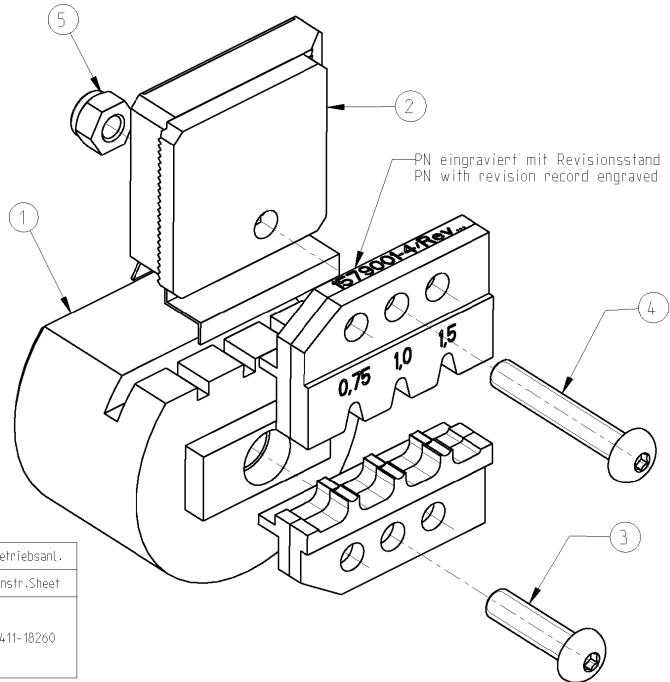

1579001-4	1	2-0744010-6	Instruction Sheet	Bedienungsanleitung	6
	1	0-0519024-2	Nut M4 DIN 985	Mutter M4 DIN 985	5
	1	1-0519151-3	Screw M4x25	Schraube M4x25	4
	1	1-0519151-1	Screw M4x16	Schraube M4x16	3
	1	0-1579005-9	Locator Assembly	Drahtanschlag	2
	1	0-1579005-8	Contact Locator	Kontaktpositionierer	1
	QTY	PN	Description	Benennung	Pos.
	Stck				

Kontakt	DGB (mm <sup>2</sup> )	Drahtcrimp / Wire Crimp		Isolationscrimp/Insulationcrimp		Isol.Ø	Betriebsant.
Contact	Wire Range	Hoehe/Height mm	Breite/Width mm	Hoehe/Height mm	Breite/Width mm	Ins.Range	Instr.Sheet
929399 / 1355669	0.75	1.19 ±0.03	1.93	2.1 ±0.1	2.13	1.7-1.9	411-18260
	1.0	1.25 ±0.03	2.03	2.3 ±0.1	2.54	1.9-2.1	
	1.5	1.44 ±0.03		2.6 ±0.1		2.2-2.4	

<small>THIS DRAWING IS A CONTROLLED DOCUMENT FOR TYCO ELECTRONICS CORPORATION                  IT IS SUBJECT TO CHANGE AND THE CONTROLLING ENGINEERING ORGANIZATION                  SHOULD BE CONTACTED FOR THE LATEST REVISION.</small>		DWN Ch.Witt 05MAY2004 CHR - APVD - PRODUCT SPEC - APPLICATION SPEC - WEIGHT - CUSTOMER DRAWING	<b>tyco</b> Electronics tyco Electronics AMP GmbH D - 64625 Bensheim	NAME ERGOGRIMP DIE SET FOR MQS 1.2 mm Ergocrimp Matrize fuer MQS 1.2 mm	RESTRICTED TO -
DIMENSIONS: mm 	TOLERANCES UNLESS OTHERWISE SPECIFIED: 0 PLC ±0.1 1 PLC ±0.1 2 PLC ±0.1 3 PLC ±0.1 4 PLC ±0.1 ANGLES ±0.5° FINISH -	SIZE A3 CAGE CODE 00779 DRAWING NO. C-1579001-4	SCALE 2:1 SHEET 1 OF 1 REV C		

AMP 1470-19 REV 31MAR2000

Pro/ENGINEER DRAWING