

PROPER USE GUIDELINES

Cumulative Trauma Disorders can result from the prolonged use of manually powered hand tools. AMP hand tools are intended for occasional use and low volume applications. AMP offers a wide selection of powered application equipment for extended-use, production operations.

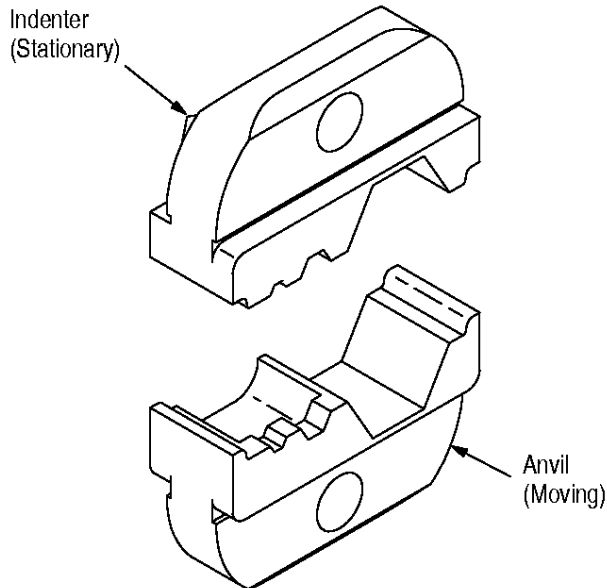

Figure 1

1. INTRODUCTION

This instruction sheet covers the use and maintenance of AMP* Crimping Die Assemblies 58485-1 and -2, which are used in AMP PRO-CRIMPER* II Frame Assembly 354940-1. The die assembly crimps various configurations (designated by different part number suffixes) of N-Series Connector 414160-[] onto coaxial cable.

NOTE

Dimensions on this sheet are in metric units [with U.S. customary equivalents in brackets].

Reasons for reissue are provided in Section 7, REVISION SUMMARY.

2. DESCRIPTION (Figure 1)

Each die assembly consists of an indenter die and an anvil die. When closed, the dies form three crimping chambers, which crimp the center contact and the ferrule of the connector onto the coaxial cable. Each die is held in the tool by a single screw.

3. DIE INSTALLATION

1. Close the tool handles until the ratchet releases, then allow the handles to open fully.
2. Insert the dies into the tool jaws as shown in Figure 2, and align the die retaining holes in each die with the associated holes in the tool.
3. Thread, but do not tighten, the die retaining screws into the holes.
4. Carefully close the tool handles, making sure that the dies align properly.
5. Tighten the die retaining screws with the appropriate hex wrench.

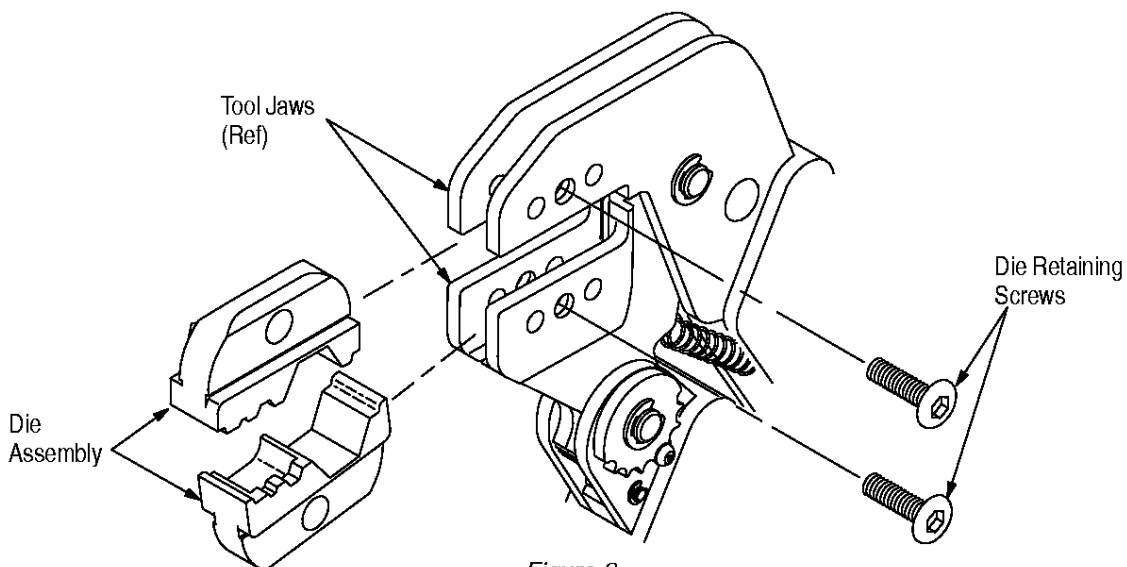

Figure 2

4. CRIMPING PROCEDURE

Before proceeding with crimping, determine the proper tool and setting to provide the center conductor crimp. Follow the manufacturer's recommended procedure.

1. Make sure that the connector's ferrule has been placed onto the cable, and that the cable's braided shield is flared away from the cable.
2. Slide the center contact onto the center conductor of the stripped cable until it is butted against the center conductor dielectric. Place the center contact into the proper crimp cavity, as specified on the product customer drawing. Close the tool handles until the ratchet releases.
3. Insert the crimped center contact into the connector body until the cable dielectric butts against the dielectric inside of the connector body or until the center contact is securely positioned within the connector. Make sure that the shield is over the support sleeve of the connector body, and that no strands from the shield enter the connector body.
4. Slide the ferrule over the braided shield and onto the connector until the ferrule butts against the shoulder on the connector body.
5. Place the assembly on the appropriate anvil of the die assembly so that the shoulder on the connector body is close to the edge of the die.
6. While holding the assembly together, begin to close the tool handles. Keep holding the assembly until the dies have closed enough to clamp the assembly in place.
7. Carefully close the tool handles until the ratchet releases.
8. Allow the tool handles to open fully and remove the crimped connector from the dies.

5. MAINTENANCE AND INSPECTION

5.1. Maintenance

1. Remove dust, moisture, and other contaminants with a clean, soft brush, or a clean, soft, lint-free cloth. Do NOT use any objects that could damage the dies or tool.
2. Make sure that the proper die retaining screws are properly secured.
3. When the dies are not in use, store them in a clean, dry area. When the tool is not in use, store it with the handles closed to prevent objects from being wedged within the jaws.

5.2. Inspection

1. Remove all lubrication and accumulated film from the dies by immersing the dies in a suitable commercial degreaser.
2. Make certain that all die retaining screws and die components are properly secured.
3. Inspect the crimping surfaces for flattened, chipped, worn, or cracked areas. If damage is evident, the dies must be replaced. Refer to Section 6, REPLACEMENT.

5.3. Measuring Die Opening

The die assembly will perform correctly as long as: (1) the product specified is correct for the application, (2) the specific die assembly is used, (3) the die assembly has been measured to ensure that the openings are correct, and (4) the die assembly bottoms.

Figure 3 provides information on die opening sizes.

For specific applications where wire stiffness, material, or insulation may give different than standard performance, it may be necessary to measure the crimped ferrule, rather than to verify the size of the die opening. This inspection requires the use of a cone or modified micrometer (Crimp Height Comparator RS-1019-5LP), which is available from:

Shearer Industrial Supply Co. VALCO
 20 North Penn Street or 1410 Stonewood Drive
 York, PA 17401-1014 Bethlehem, PA 18017-3527

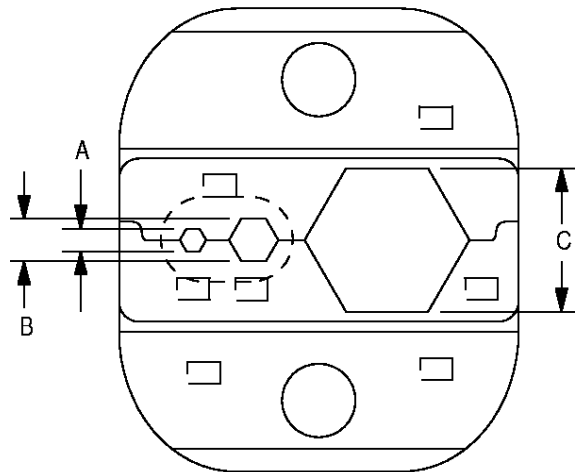

DIE ASSEMBLY PART NO.	DIE OPENING (±0.08 mm [.003 in.])		
	A	B	C
58485-1	1.73 [.068]	2.54 [.100]	10.90 [.429]
58485-2	1.73 [.068]	3.25 [.128]	10.90 [.429]

Figure 3

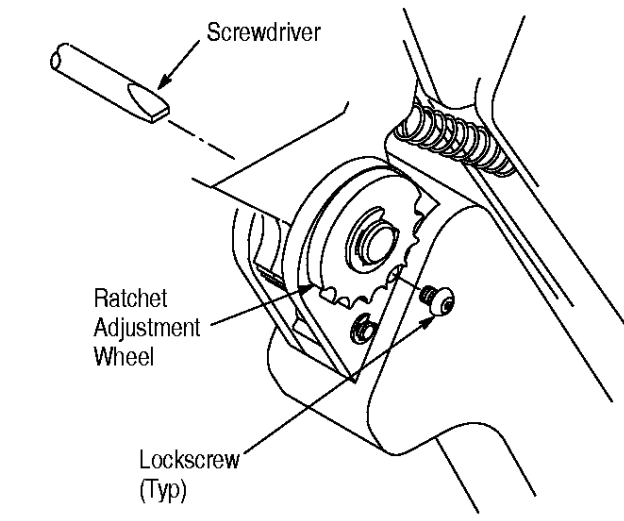

Figure 4

5.4. Ratchet Adjustment (Figure 4)

The tool frame assembly ratchet mechanism features an adjustment wheel with numbered settings. If the crimp height is not acceptable, adjust the ratchet as follows:

1. Remove the lockscrew from the ratchet adjustment wheel.
2. With a screwdriver, adjust the ratchet wheel from the opposite side of the tool.
3. Observe the ratchet adjustment wheel. If a tighter crimp is required, rotate the adjustment

wheel COUNTERCLOCKWISE to a higher-numbered setting. If a looser crimp is required, rotate the adjustment wheel CLOCKWISE to a lower-numbered setting.

4. Replace the lockscrew.

5. Make a sample crimp and measure the crimp height. If the crimp height is acceptable, secure the lockscrew. If the dimension is unacceptable, remove lockscrew and continue to adjust the ratchet, and again measure a sample crimp.

6. REPLACEMENT

Order replacements through your AMP Representative, or call 1-800-526-5142, or send a facsimile of your purchase order to 1-717-986-7605, or write to:

CUSTOMER SERVICE (38-35)
AMP INCORPORATED
P.O. BOX 3608
HARRISBURG, PA 17105-3608

7. REVISION SUMMARY

Since the previous release of this sheet, the following changes were made:

Per EC 0990-1165-98

- Updated crimp cavity procedure in Section 4, Step 2