

## PROPER USE GUIDELINES

Cumulative Trauma Disorders can result from the prolonged use of manually powered hand tools. AMP hand tools are intended for occasional use and low volume applications. AMP offers a wide selection of powered application equipment for extended-use, production operations.

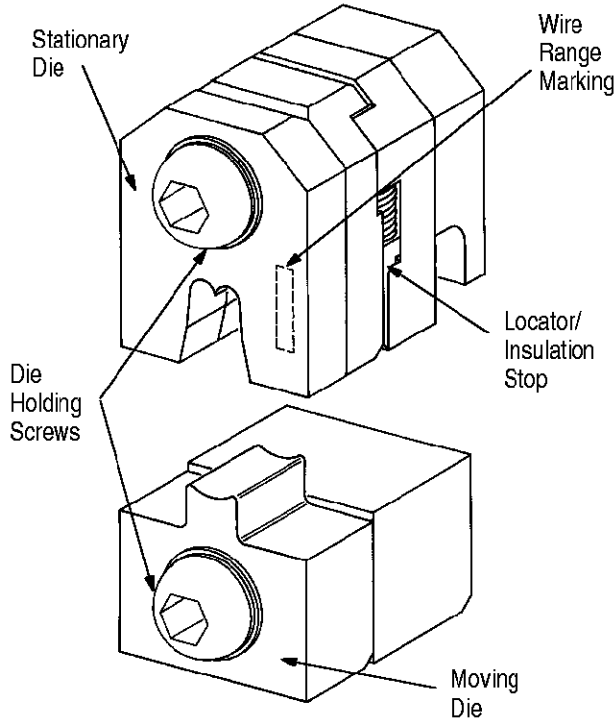

Figure 1

## 1. INTRODUCTION

AMP\* Interchangeable Crimping Die Assemblies 58373-1 and 58374-1 (see Figure 1) are designed to be used in AMP Hand Crimping Tool 69710-1 and AMP Pneumatic Tools 69365, 69365-2, and 69365-3 to crimp AMP .140 MATE-N-LOK\* loose piece pin and socket contacts listed in Figure 2. Die set 58373-1 crimps No. 10 AWG wires and die set 58374-1 crimps 14-12 AWG wires. Read these instructions thoroughly before starting.

### NOTE

Measurements are in millimeters [followed by inch equivalents in brackets]. Figures and illustrations are for identification only and are not drawn to scale.

Reasons for reissue are provided in Section 7, REVISION SUMMARY.

## 2. DESCRIPTION

Each crimping die assembly consists of a moving die and a stationary die, as shown in Figure 1. The moving die is positioned in the lower portion of the

tool head and is attached to the moving die holder by a die holding screw. The stationary die is secured to the stationary die holder located in the upper portion of the tool head.

## 3. DIE INSTALLATION

If using the hand tool, follow the die installation steps in Paragraph 3.1; if using any of the pneumatic tools, follow the die installation steps in Paragraph 3.2.

### 3.1. Hand Tool

1. Position stationary die in stationary die holder and moving die in moving die holder. See Figure 3. Fasten die holding screws enough to hold dies in place but do NOT tighten fully.
2. Close handles until the dies bottom. Then tighten both holding screws. The tool can now be used to crimp the contacts to wires.

### NOTE

Check die alignment and tighten die holding screws.

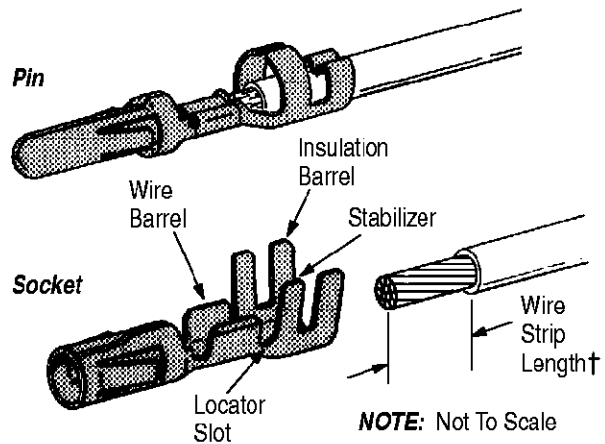

† If insulation diameter range is 2.54-3.78 [.100-.149], wire strip length is 6.35 [.250]; if insulation diameter range is 3.81-4.06 [.150 to .160], wire strip length is 7.92 [.312].

CRIMPING DIE PART NUMBER	WIRE SIZE (AWG)	INSUL DIA RANGE†	CRIMP SECT WIRE SIZE MARKING	CONTACT PART NUMBER	
				STRIP	LOOSE PIECE
58374-1	14-12	2.54-4.06	14-12	350200	350390
58373-1	10	[.100-.160]	10	350201	350391

Figure 2

### 3.2. Pneumatic Tools

If using AMP Pneumatic Crimping Tool 69365, the manual take-up attachment 307569-1 should be installed on the tool before crimping. Refer to AMP Instruction Sheet packaged with the manual take-up attachment 307569-1 for installation instructions.

1. Shut off air supply.
2. Position stationary die in stationary die holder and moving die in moving die holder. Refer to Figure 1. Fasten die holding screws enough to hold dies in place but do NOT tighten fully.
3. Reconnect air supply. Then activate tool by depressing trigger or foot switch until dies bottom. Fully tighten both die holding screws while dies are bottomed. The tool is now ready for crimping.

#### DANGER

*Avoid personal injury. Always keep fingers clear of crimping area when air is connected.*

#### NOTE

*Check die alignment and tighten die holding screws.*

### 4. CRIMPING PROCEDURE

The steps which follow are recommended to crimp wires to the contacts listed in Figure 2. Proceed as follows:

1. Refer to the table in Figure 2 and select stranded wire of the specified size and insulation diameter and the applicable contact for that wire size and insulation diameter. Strip the wire to the length indicated — do NOT cut or nick the wire strands.
2. Orient the tooling so the FRONT is facing you. See Figure 3.
3. Insert contact — insulation barrel first — into the BACK of the crimp section. Position contact in crimpers so that (tool) locator enters locator slot in contact.
4. Hold contact in this position and close dies just enough to hold contact in place — do NOT deform contact.
5. Insert a properly stripped wire through the wire slot in the locator and into the wire barrel of the contact until the insulation butts against locator/insulation stop.

#### NOTE

*If using hand tool, you will note that the crimping dies bottom before the ratchet releases. This is a design feature that ensures maximum electrical and tensile performance of the crimp. Do NOT re-adjust the ratchet.*

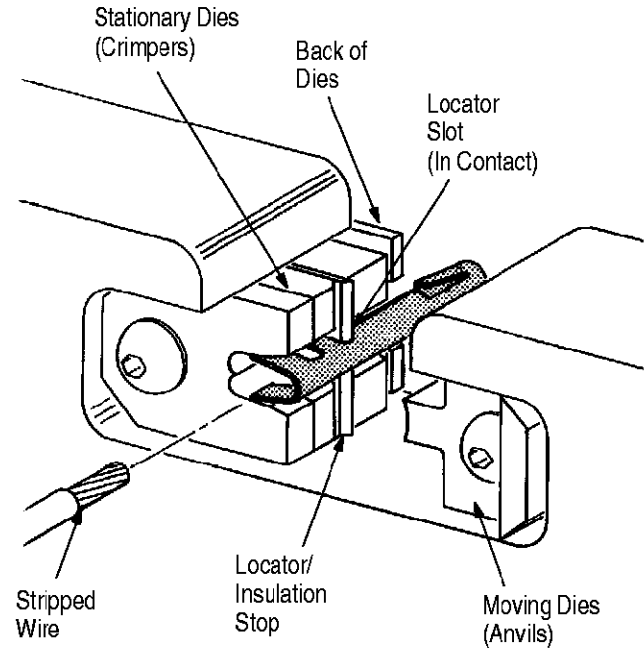

Figure 3

6. Holding wire in place activate tooling to perform a complete cycle. For the hand tool, squeeze the handles until the ratchet releases. For pneumatic tooling, depress either the trigger or foot switch.
7. Remove crimped contact from between the upper and lower dies. The tool can now be used to crimp more contacts.

### 5. MAINTENANCE AND INSPECTION PROCEDURE

#### DANGER

*To avoid personal injury, ALWAYS release hydraulic pressure to hose or control and disconnect power unit from power supply before performing maintenance or inspection procedure.*

AMP recommends that a maintenance and inspection program be performed periodically to ensure dependable and uniform terminations. Frequency of inspection should be adjusted to suit your requirements through experience and depends on:

1. The care, amount of use, and handling of the crimping die.
2. The type and size of the product crimped.
3. The degree of operator skill.
4. The presence of abnormal amounts of dust and dirt.
5. Your own established standards.

Each crimping die is thoroughly inspected before packaging. Since there is a possibility of damage during shipment, crimping die should be inspected immediately upon arrival at your facility.

**5.1. Daily Maintenance**

It is recommended that each operator of the dies be made aware of—and responsible for—the following steps of daily maintenance:

1. Remove dust, dirt, and other contaminants with a clean brush, or a soft, lint-free cloth. Do NOT use objects that could damage the dies.
2. Make certain the dies are protected with a THIN coat of any good SAE 20 motor oil. Do NOT oil excessively.
3. When the dies are not in use, mate them and store in a clean, dry area.

**5.2. Periodic Inspection**

Regular inspections should be performed by quality control personnel. A record of scheduled inspections should remain with the dies and/or be supplied to supervisory personnel responsible for the dies. Though recommendations call for at least one inspection a month, the inspection frequency should be based on the amount of use, ambient working conditions, operator training and skill, and established company standards. These inspections should be performed in the following sequence:

**A. Visual Inspection**

1. Remove all lubrication and accumulated film by immersing the dies in a suitable commercial degreaser that will not affect paint or plastic material.
2. Make sure all die components are in place. If replacements are necessary, refer to the replacement parts listed in Figure 5.
3. Check components for wear. Remove and replace worn components.
4. Inspect the crimp area for flattened, chipped, cracked, worn, or broken areas. If damage is evident, the dies must be repaired before returning them to service (see Section 6, REPLACEMENT AND REPAIR).

**B. Crimp Height Inspection**

This inspection requires the use of a modified micrometer with a modified anvil and spindle, as shown in Figure 4. AMP recommends the Crimp Height Comparator RS-1019-5LP which can be purchased from:

Shearer Industrial Supply Co.      VALCO  
 20 North Penn Street      or      1410 Stonewood Drive  
 York, PA 17401-1014      Bethlehem, PA 18017-3527

Proceed as follows:

1. Refer to the table in Figure 2 and select a contact and a wire for each crimp section. Use the **MAXIMUM** size wire for each crimp section.
2. Refer to Section 4, CRIMPING PROCEDURE, and crimp the contacts accordingly.
3. Using a crimp height comparator, measure the wire barrel crimp height as shown in Figure 4. If the crimp height conforms to that height, the tool is considered dimensionally correct. If not, the tool must be returned to AMP for evaluation and repair. See Section 6, REPLACEMENT AND REPAIR.

For additional information concerning the use of the crimp height comparator, refer to AMP instruction sheet 408-7424.

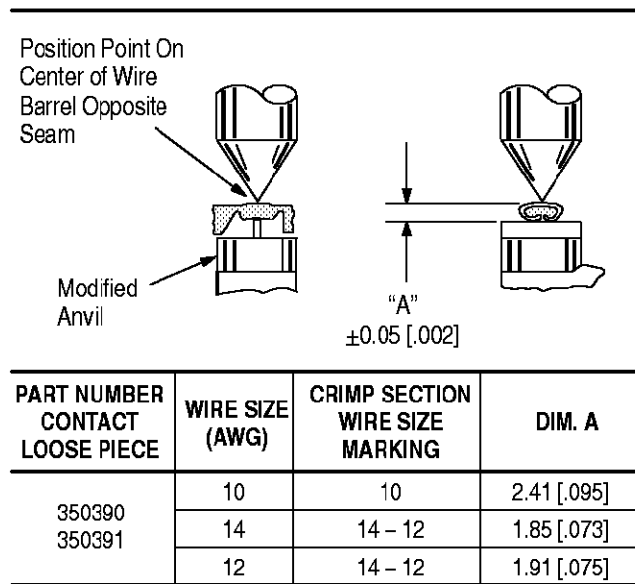

Figure 4

**6. REPLACEMENT AND REPAIR**

Replaceable parts are listed in Figure 5. Parts other than those listed in Figure 5 should be replaced by AMP to ensure quality and reliability of the tool. Order replacement parts through your AMP representative, or call 1-800-526-5142, or send a facsimile of your purchase order to 1-717-986-7605, or write to:

CUSTOMER SERVICE (38-35)  
 AMP INCORPORATED  
 P.O. BOX 3608  
 HARRISBURG, PA 17105-3608

For repair service, please contact an AMP representative at 1-800-526-5136.

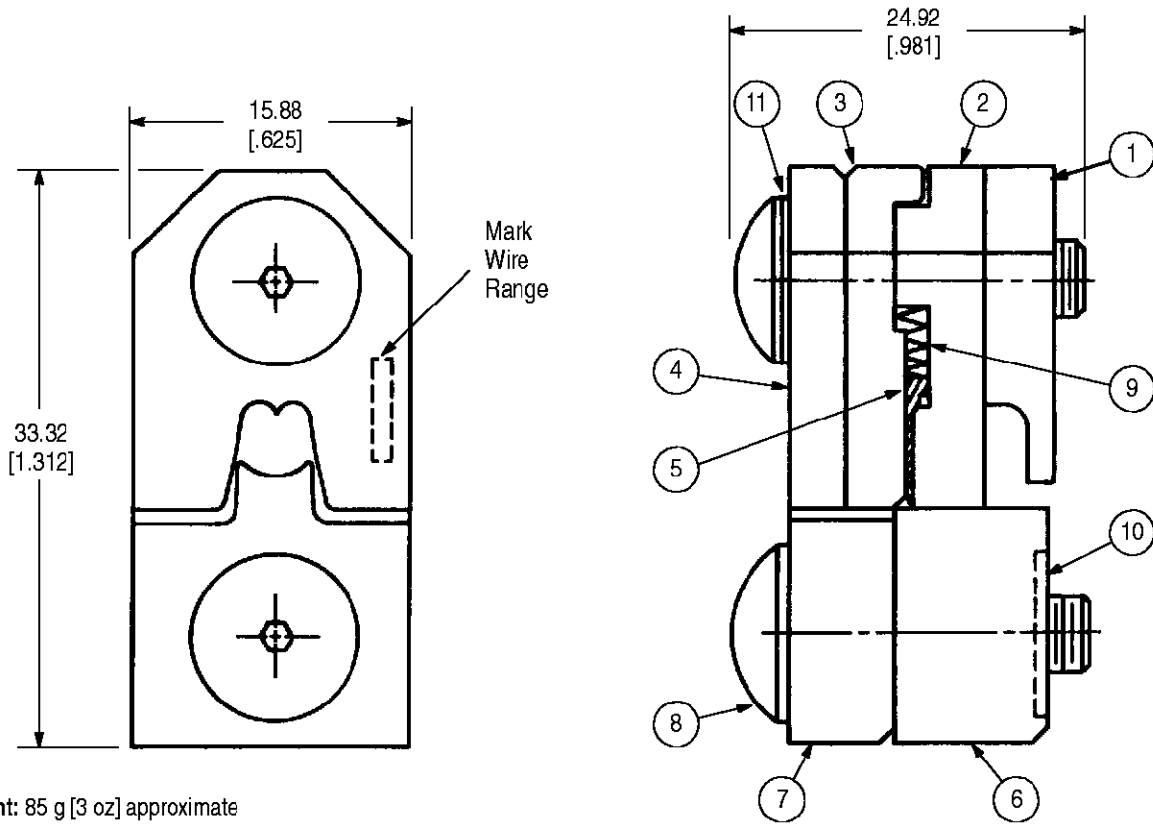

Weight: 85 g [3 oz] approximate

**REPLACEMENT PARTS**

ITEM	DIE ASSEMBLY PART NUMBER		DESCRIPTION	QTY PER ASSY
	58373-1	58374-1		
1	314079-1	314079-1	SUPPORT, Upper	1
2	314077-2	314077-1	CRIMPER, Wire	1
3	314075-1	314075-1	STABILIZER	1
4	314078-2	314078-1	INSULATION, Upper	1
5	314076-1	314076-1	LOCATOR, Wire Stop	1
6	314081-2	314081-1	ANVIL, Wire	1
7	314080-1	314080-1	ANVIL, Insulation	1
8	1-306105-1	1-306105-1	SCREW, Special	2
9	305182	305182	SPRING	2
10	1-21046-3	1-21046-3	RING, Retaining	2
11	24088-7	24088-7	WASHER, Curved	1

Figure 5

**7. REVISION SUMMARY**

Since the previous release of this sheet, the following changes were made:

Per EC 0990-1115-99:

- Updated document to corporate requirements
- Changed document title
- Changed tool repair service information in Section 6, REPLACEMENT AND REPAIR